

## **Module 1**

### **INTRODUCTION TO MECHATRONIC SYSTEMS**

#### **CONTENTS**

- 1.1 Introduction
- 1.2 Definition of Mechatronics
- 1.3 Multi-disciplinary scenario.
- 1.4 Origin of Mechatronic system.
- 1.5 Evaluation of Mechatronics.
- 1.6.1 Advantages of Mechatronic Systems
- 1.6 .2 Disadvantages of Mechatronic Systems.
- 1.7 Generalized measurement system
- 1.8 Functions of each units used in measurement system
- 1.9 Microprocessor based controllers:
  - 1.9.1 Block diagram of Mechatronic System
  - 1.9.2 Block diagram of working automatic camera
  - 1.9.3 Block diagram of working automatic washing machine
  - 1.9.4 Block diagram of working engine management system.
- 1.10 PLC (Programmable Logic Controller).

#### **OBJECTIVES**

- To understand the concepts of mechatronics systems and its applications.
- To understand the how microprocessor based controllers works.

## 1.1 Introduction:

An automation and control method adopting integrated approach to technology has become relevant to industries, machinery and consumer engineering products. Most of the domestic equipment like automatic washing machines, automatic cameras, digital cameras, DVD players, hard disc drives are examples of Mechatronic system which we use without bothering to know the technology adopted in it.

## 1.2 Definition of Mechatronics:

### Definition 1:

Mechatronics may be defined as” the complete integration of mechanical system with electronics, electrical and computer system into a single system”.

### Definition 2:

Mechatronics is “the synergistic (Together) combination of mechanical engineering, electronic engineering, control engineering and systems thinking in the design of products and manufacturing processes”

**Example:** automatic washing machine, digital fuel injection system, engine management system. Etc.,

## 1.3 Multi-disciplinary scenario:

- Mechatronics is the synergistic (Together) combination of mechanical engineering, electronic engineering, control engineering and systems thinking in the design of products and manufacturing processes”.
- Multi-disciplinary products are not new; they have been successfully designed and used for many years. Most common is the electromechanical system.
- It employs a sequential design-by-discipline approach. For example in the design of electromechanical system three stages of design are adopted.
- They are design of mechanical system, design of microelectronic system and control system.
- Each design application follows the completion of the previous one.
- to overcome drawbacks Mechatronics uses concurrent engineering.

### 1.4 Origin of Mechatronic system:

- The word Mechatronics was coined by Japanese in the late 1970's to describe the philosophy adopted in the design of subsystem of electromechanical systems.
- The field of Mechatronics received the international recognitions only in the last few years.
- The field has been derived by rapid progress in the field of microelectronics.
- At R&D level the following areas have been recognized under Mechatronics discipline.
  - a) Motion control actuators and sensors
  - b) Micro devices and optoelectronics
  - c) Robotics
  - d) Automotive systems
  - e) Modeling and design
  - f) System integration
  - g) Manufacturing
  - h) Vibration and noise control.

### 1.5 Evaluation of Mechatronics:

The technology has evolved through several stages that are termed as levels. The evolution levels of Mechatronics are:

- a. Primary level Mechatronics (first)
- b. Secondary level Mechatronics (second)
- c. Tertiary level Mechatronics (third)
- d. Quaternary level Mechatronics (fourth)

#### a. Primary level Mechatronics (first):

- In the early days Mechatronics products were at primary level containing I/O devices such as sensors, and actuators that integrated electrical signals with mechanical action at the basic control level.

**Examples:** electrically controlled fluid valves and relays

#### b. Secondary level Mechatronics (second):

- This level integrates microelectronics into electrically controlled devices.

**Examples:** cassette player.

### c. Tertiary level Mechatronics (third):

- This incorporates advanced feedback functions into control strategy, thereby enhancing the quality in terms of sophistication.
- Mechatronics system at this level is called '**smart system**'.
- The control strategy includes microelectronics, microprocessor and other „application specific integrated circuits“ (ASIC).

**Examples:** DVD player, CD drives, automatic washing machine, CD drives, etc.

### d. Quaternary level Mechatronics (fourth):

This level includes intelligent control in Mechatronics system.

The level attempts to improve smartness a step ahead by introducing intelligence and fault detection and isolation (FDI) capability system.

**Examples:** artificial neural network and fuzzy logic technologies.

## 1.6.1 Advantages and disadvantages of Mechatronics:

### Advantages:

1. The products produced are cost effective and very good quality.
2. High degree of flexibility
3. Greater extent of machine utilization
4. Greater productivity
5. High life expected by proper maintenance.
6. The integration of sensor and control system in a complex system reduces capital expenses.

### 1.6.2 Disadvantages:

1. Higher initial cost of the system.
2. Imperative to have Knowledge of different engineering fields for design and implementation.
3. It is expensive to incorporate Mechatronics approaches to existing/old systems.
4. Specific problem of various systems will have to be addressed separately and properly.

## 1.6.3 Characteristics of Mechatronic system:

1. High quality product.
2. Safe.

3. Low cost.
4. Portable produced quickly
5. Serviceability, maintainability and upgradeability.

### 1.6.4 Applications of Mechatronic systems:

The areas are:

1. Automotive machines.
2. Fax and photocopier mechanics
3. Dishwashers.
4. Automatic washing machine
5. Air conditioners, elevator controls.
6. Documents scanners
7. IC manufacturing systems.
8. Robotics employed in welding, nuclear inspection, painting etc.,
9. VCRs and CD Players.

**Measurement system:** a group of device/element arranged in rational manner to achieve the act of measurement.

**Measurand:** is a numerical quantity of physical phenomenon such as force, quantity, displacement, time, velocity, etc,

**Measurement:** is a represent of physical phenomenon in numerical values.

### 1.7 Generalized measurement system:

Generally a measurement system consists of 3 basic elements.

1. Sensor/transducer.
2. Signal conditioner.
3. Display/read out devices.

In addition to the above, electrical power is also required.

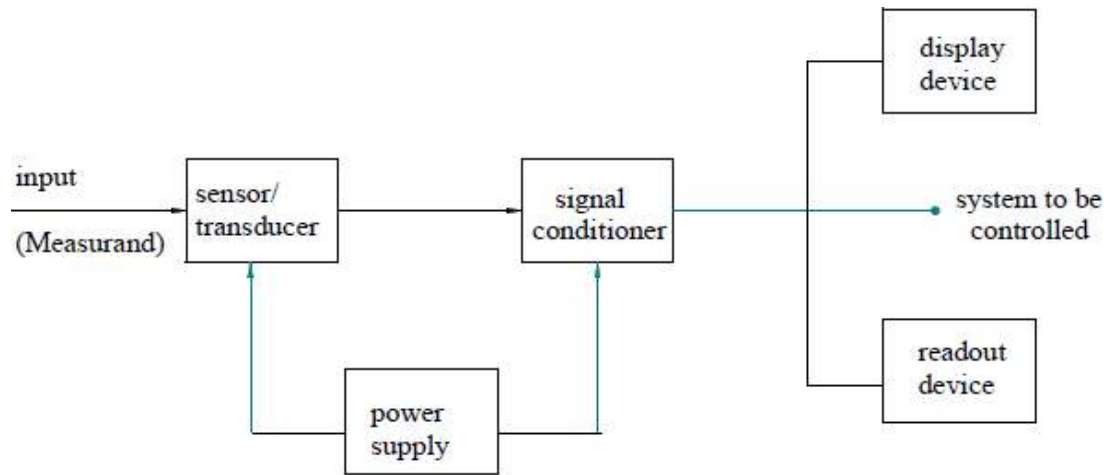


figure: block diagram of generalised measurement system

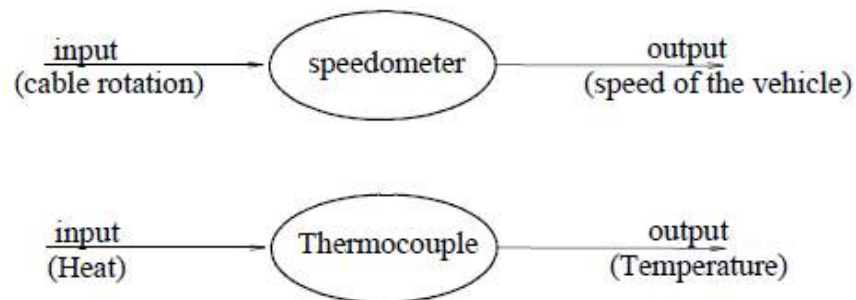


figure: concept of measurement

## 1.9 Functions of each elements of measurement system:

### 1.9.1. Sensor/transducer unit:

- The heart of any measurement or control system is sensor/transducer.
- Sensor/transducer is a device it converts the one form of energy to another form.
- Sensor/transducer it senses the physical phenomenon to be measure and transform it from one form to another form (generally electrical form).
- The output of this unit is input to the signal conditioner which is next element.

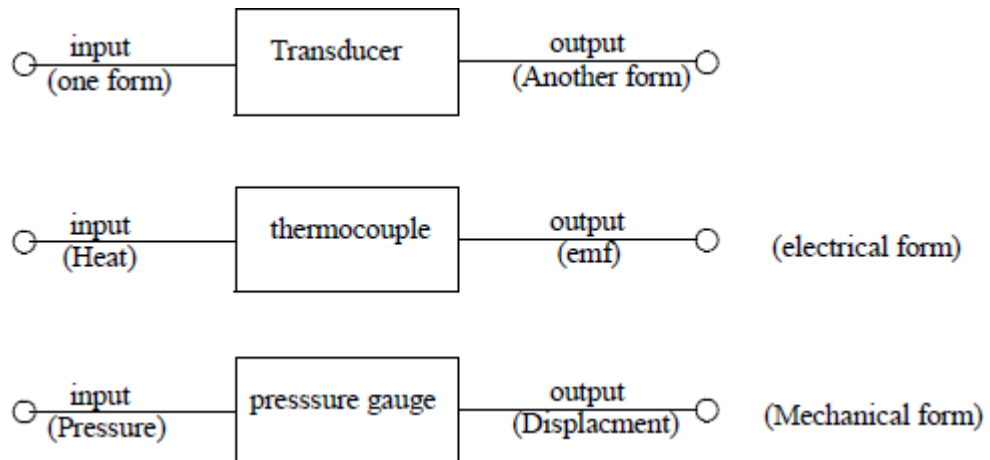


Fig 2: Elements of measurement system

### 1.9.2. Signal conditioner unit:

- This unit senses the output signals of sensor and converts it into suitable, measurable level of signals.
- An amplifier acts as a signal conditioner in the figure.

The following functions of signal conditioners are:

- Amplification of signals:** the level of signals from the transducer may be of low level for the next use and hence need to be amplified (increased).
- Attenuation:** similarly the level of signals from the transducer may be of higher level for the next use and hence need to be attenuated (decreased).
- Filtering:** signals from the transducer may contain some other undesirable signals which need to be filtered or eliminated before it is used. Otherwise a corrupt output will be generated.
- Analog to digital conversion (ADC):** the signals from the transducer may be analog in nature and if these signals were to be used as input to electronic system/computer system, they need to be converting to digital form. Similarly sometimes we use DAC.

### 1.9.3. Display/read out unit:

- It displays the output of signal conditioner unit and this display will be the quantitative form of measurand.
- Display unit may be either of analog (dial gauge) and digital (LED) type.



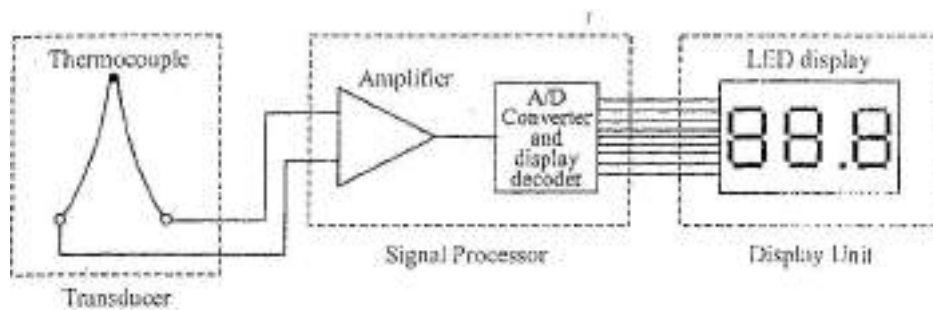
**Example of Measurement system: Digital thermometer principle**

Fig 3: Digital thermometer principle

**1.9.4 Control system:**

The word control means „to regulate“, „manipulate“, and „command“.

**Examples:**

1. A container is to be filled with water from a tap. Once the water fills the container, the valve is closed (that is spilling of water is avoided) by observation from a human being who senses the filling and based on the observation closes the valve.
2. The driver applies the brake of the vehicle, when he/she observes red traffic light.

**Definition of Control system:**

A group of devices/elements which maintains the required output based on the predefined value by controlling the parameter responsible for output.

**Classification of control system:**

1. Open loop control system (NO FEEDBACK control system).
2. Closed loop control system (WITH FEEDBACK control system).

**1. Open loop control system (NO FEEDBACK control system):**

In which the output is dependent on the input, but input is independent of output is called open loop control system.

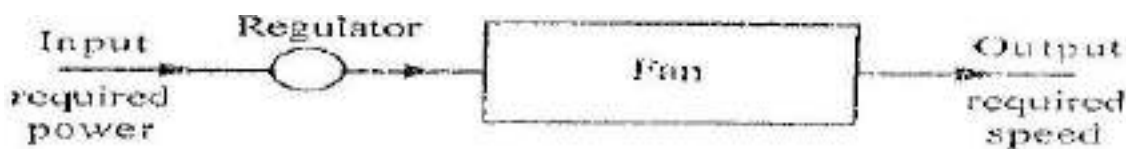


Fig 4: Open Loop System

**Example:**

1. **ON/OFF of an electric lamp:** electric lamps are used for lighting the lamp. ON/OFF control is carried out with the help of a switch and the switch is generally operated by an operator depending on the amount of light that exist in that area.

If the switch is ON, the lamp is glow. If the person operating the switch does not put OFF of the switch, the lamp remain ON until he switched OFF. So it is called open loop control system.

2. **Control the temperature of the room with room heater:** the amount of heat generated by a room heater depends on the amount of input power controlled by a regulator.

If the power is switch ON, the power supplied to the heater continues and temperature of the room goes on increasing immaterial of whether heat is required in the room or not. Here person is go and OFF the power supply switch and there by cooling the temperature of the room is decreasing.

**Advantages of open loop control system:**

1. Less costly.
2. Relatively simple.
3. Good reliability.
4. Easy maintenance.
5. Inherently stable.

**Disadvantages of open loop control system:**

1. Inaccurate since there is no correction of error.
2. Relatively slow in response to change in demand.
3. The control depends on the human judgment.
4. Often leads to waste.
5. Any change in system component not to be taken care automatically.

**2. Closed loop control system (WITH FEEDBACK control system):**

**In which input is depend on the output.** i.e., variation in the output influences the input by some means of controlling on the input is called a closed loop system.

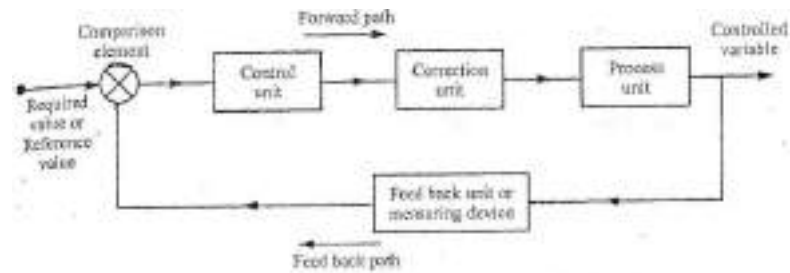


Fig 5: Closed loop control system

### Elements of closed loop control system:

The basic elements of a closed loop control system are:

1. Comparison element.
2. Control unit.
3. Correction unit.
4. Process unit.
5. Feedback unit.

### Functions of each elements of a closed loop system:

**Comparison element:** this unit compares the reference value with feedback value and produces an error signal.

### Error = reference value – feedback value

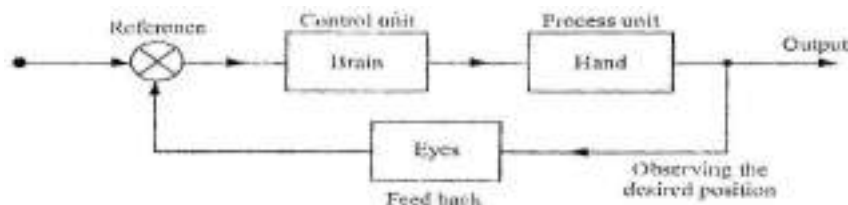
**Control unit:** Control unit analyses the error signal and decides what action is to be taken.

**Correction unit:** the modified signal from the control unit will be received by the correction unit which produces a change in the process to correct or change the controlled condition.

**Process unit:** process unit is the unit which is being controlled.

### Examples:

1. **Hand reaching an object.**



- ✓ This is an example of closed loop control system.
- ✓ A person wants to reach for an object.
- ✓ Position of the object is given as reference, feedback signals and the eyes compares the actual position of the hands with reference to the position of the object.
- ✓ Error signal is given to the brain.
- ✓ Brain manipulates this error and gives signals to the hands.
- ✓ This process continues till the hand reaches the object.

## 2. Speed control of an automobile:

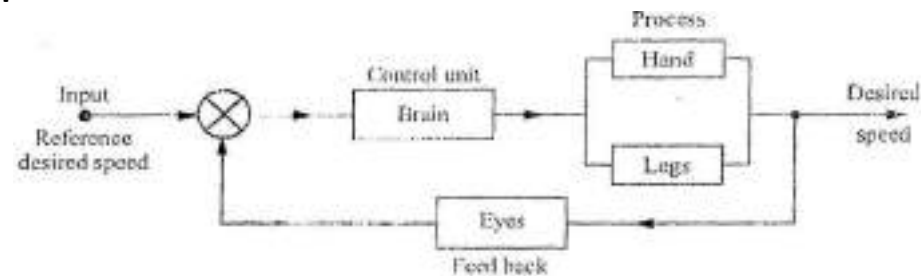


Fig 6: Closed loop control system

- ✓ The driver observes the speedometer, and based on the speed shown by the speedometer he decides whether the fuel supply should be increased or decreased or gear change is to be made.
- ✓ Here speed shown a speedometer is a feedback. A feedback signal from the eye compares the desired speed in the memory of the driver.
- ✓ Error signals are given to brain. Brain manipulates the error signals and gives it ton hand and leg and increase the fuel supply if the speed is less than the desired speed, otherwise decrease the fuel supply.
- ✓ Changing of gear and increase or decrease of fuel supply, depends on whether it an upward or downward gradient respectively.

## 3. Water level control of overhead tanks:

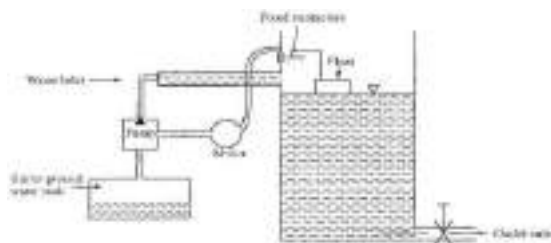


Fig 7: Water level controller

- ✓ The overhead tank has a fixed float (sensor) fixed at the desired height inside the tanks.
- ✓ The level of the water is sensed by the float. The float has an electrical contactor, which is positioned between fixed connectors.
- ✓ The inflow regulation valve is electrically operated. The electrical circuit of the system is closed when the float touches the fixed connectors and open when it is not making contact with it.
- ✓ When the level of water in the tank falls, the float moves down and makes contact with fixed contactor and circuit is closed and pump is switched ON.
- ✓ When the level of water rises the float moves up and breaks the circuit and pump is switches OFF. Thereby the required level of water is maintained in overhead tank.

### 3. Room temperature controller (manual):

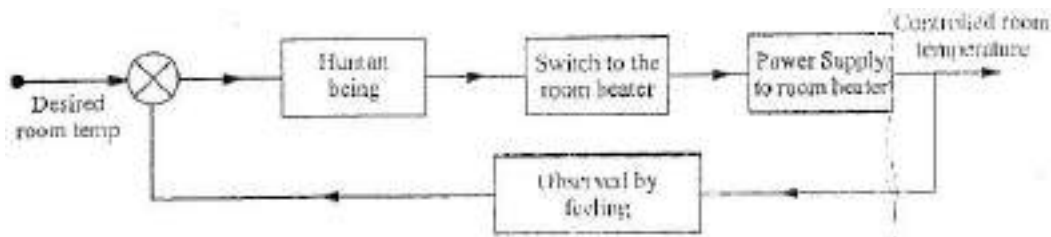


Fig 8: Room Temperature Controller

- ✓ In this case the required room temperature will be decided by person in the room and thus is compared mentally.
- ✓ Based on whether the room temperature is high or low, the person will operate the switch of the room heater till the desired or comfortable temperature is achieved.
- ✓ Block diagram is illustrating the above process.

### Advantages of closed loop control system:

1. More accurate.
2. Any change in system component can be taken care automatically.
3. Use of feedback system response is relatively insensitive to external disturbances and internal variations in system parameters

**Disadvantages of closed loop control system:**

1. Expensive and complicated to construction.

**Differences between open loop control system and closed loop control system**

SI No.	Open loop control system	Closed loop control system
01	Without feedback unit	With feedback unit
02	Output is depended on input	Input is depended on output
03	Less accurate	More accurate
04	Less expensive and easy to build	Expensive and Complex to build.
05	Slow in response to change in demand	High in response to change in demand
06	Stability can be ensured	May be an unstable at times
07	Input factor is the sole factor for providing the control action.	The control action is provided by the difference between the input command and corresponding output.
08	Control adjustment is depends upon the human judgment and estimation	Control adjustment is depends upon output and feedback element.
09	Any change in system component cannot be taken care automatically	Any change in system component can be taken care automatically
10	<b>Example:</b> ON/OFF of electric lamp, Controlling of fan speed, etc	<b>Example:</b> automatic washing machine, digital camera, robots etc.,

**Sequential control system:**

- Control of sequences of operations in a sequence is called as a sequence control system.
- Working of washing machine is a sequential control system wherein control is exercised based on event, or parameter etc., i.e., control action will be executed one after another event.
- The events to be carried out in a domestic washing machine are soaking, washing, rinsing and drying.
- Each of these operations involves a number of steps.

**1.9 Microprocessor based controllers:****1.9.1 Introduction:**

Recent development in the large scale integration (LSI), VLSI, SVLSI of semiconductor devices and the resulting availability of inexpensive microprocessor, memory chips and analog to digital converters (ADC) have made it possible to use computer as integral part of control system without much increase in cost. Some of the application areas of microprocessor and microcontroller based control system include; Automatic washing machine, automatic cameras, ATM, Computers, Automatic engine management systems, Disc drivers in system, Industrial automations, etc.,

**1.9.2 Block diagram of a microprocessor based control system:**

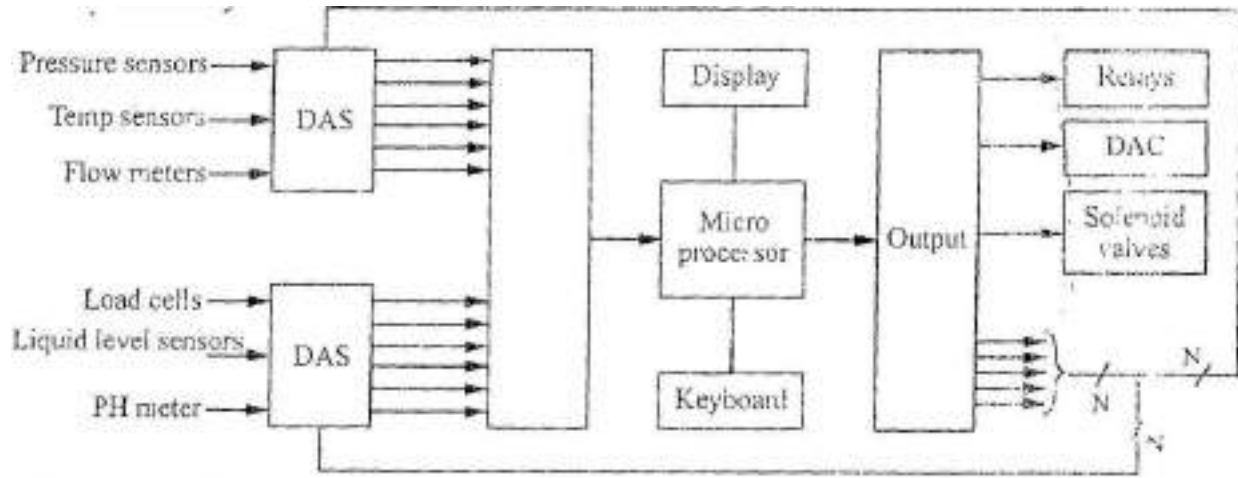


Fig 9: Microprocessor based control system

- ✓ Using data acquisition system (DAS) which converts the analog signals, from various sensors to digital signals that can be processed by a microprocessor.
- ✓ A keyboard in the system allow the user to enter set point values which are stored in the memory and the feedback of the current values of the process variable are into the memory, Relays, solenoids values, DAC and other actuators are used to control the process variables using the program.

**1.9.3 Block diagram of a microprocessor based processor control system of an Automatic camera:**

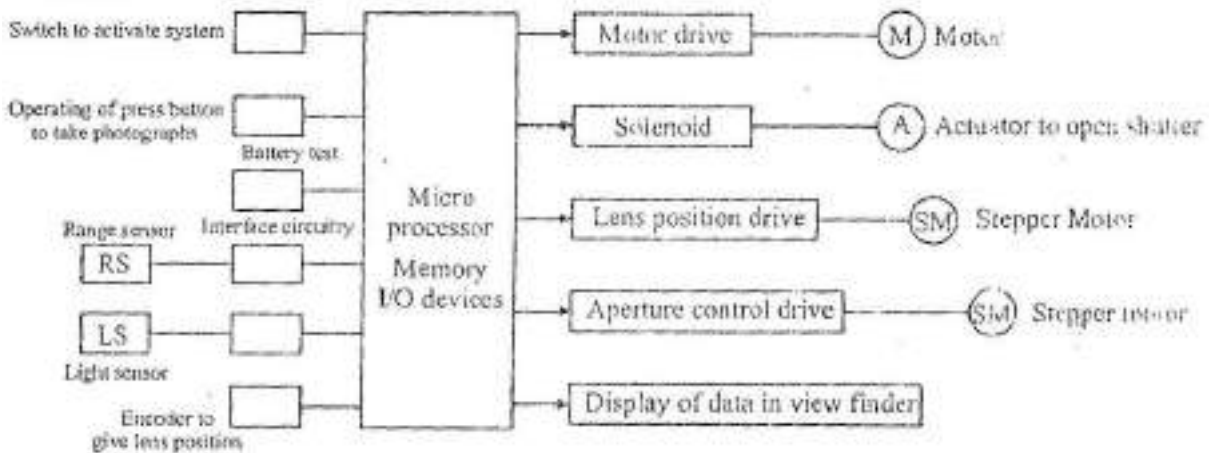


Fig 10: Automatic Camera

**Working:**

- Camera is used to photograph an object, the switch is pressed which activates the system.
- The range sensor sense the distance of the object to be photographed and this data is input to microprocessor.
- The microprocessor in turn sends on output to motor to drive to position the lens for focusing.
- The position of the lens is input to microprocessor.
- Next the light sensor sends the signal of light intensity on the object to microprocessor.
- Based on this, signals are sent to control the duration of time the shutter have to be kept open.
- All these action and reaction take place within a fraction of second.
- Once the film has exposed, the information is input to the microprocessor which gives output for driving the motor for advancing the film to drive and the camera is ready for the next exposure.

#### 1.9.4 Block diagram of a microprocessor based processor control system of Automatic washing machine:

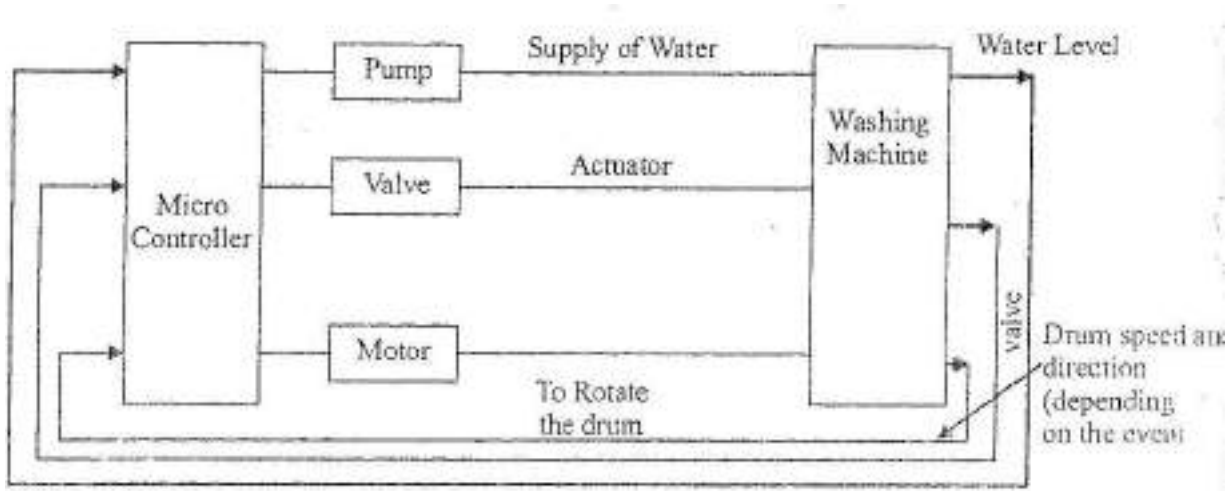


Fig 10: Automatic Washing Machine

**Working:**

- This is a sequential control system wherein control is exercised based on event, or parameter etc.,



i.e., control action will be executed one after another event.

- The events to be carried out in a domestic washing machine are soaking, washing, rinsing and drying.
- Each of these operations involves a number of steps.
- Soaking involves selection of correct quantity of detergent and water based on the type and amount of cloth.
- This requires opening of the valve to fill the machine drum to required level and closing the valve once the required level of water has reached and rotating the drum in either directions for a pre-set amount of time during the soaking operation.
- This is followed by washing which is a time parameter event.
- Then the rinsing event which measures the pH value using a chemical sensor of water in the drum and compares it with supply of water.
- This event continues till the pH value of the water in the cloth and the supply water are equal.
- Finally drying operation till the minimum percentage of moisture is retained in the cloth.
- All these events were earlier controlled with the help of mechanical system involving a set of camoperated switches.
- ✓ In modern washing machine mechanical system is replaced by digital devices. i.e., a microcontroller and the sequence of instruction; program embedded in the microcontrollers.
- ✓ The amount of detergent, amount of water, pH value are all sensed by the sensor and these sensed qualities are input to the microcontroller.
- ✓ Based on the input and the software embedded, the corresponding output of the microcontroller to carry out the different sequence of operations.

### 1.9.5 Block diagram of Engine management system using microprocessor:

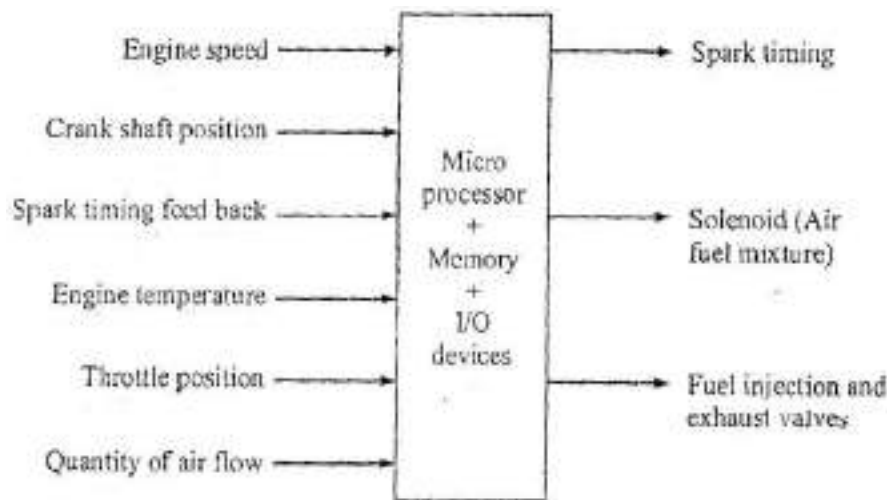


Fig 11: Engine Management System

**The figure illustrates the basic concept of engine management system using a microprocessor.**

- Engine management system is used for managing the ignition and air/fuel requirement of an IC engine.
- In the case of four stroke multi cylinder petrol engine, each cylinder has a piston performing all the four stroke (suction, compression, working or expansion and exhaust strokes) and the piston rod of each
- Piston connected to common crankshaft, and their power strokes at different time's resulting power for rotation of the crankshaft.
- The power and speed of an engine are functions of ignition timing and air/fuel mixture.
- Hence, by controlling the ignition timing and air/fuel mixture it is possible to control the speed and power of the engine.
- In modern cars the ignition timing, opening and closing of valves at appropriate time, quality of air/fuel mixture are controlled by microprocessor with the help of sensors.
- ✓ For ignition timing the crankshaft drives a distributor which makes electrical contacts for each spark plug and turns a timing wheel.
- ✓ The timing wheel generates pulses which are input the microprocessor.

- ✓ The microprocessor as per the program adjusts the timing at which high voltage pulses are sent to the distributor so that spark occurs at the right time resulting in complete combustion of fuel.
- ✓ The quantity of air/fuel mixture entering the cylinder during suction stroke is again controlled by microprocessor by varying the time for which the solenoid is activated to open the intake and throttle position.
- ✓ The quantity of fuel injected into the air stream is sensed by sensor of the mass flow rate computed from one method, and then input to the microprocessor which in turn gives an output to control the fuel injection.

### **1.10 PLC (Programmable Logic Controller):**

- PLC is also called as modern computers.
- In industry control applications are carried out by specialized devices for interfacing with analog and digital devices with restricted instruction sets using programmable logic controllers offers more flexibility in developing complex control algorithms and best suited for industrial monitoring and control, in production environments.

They are usually programmed with ladder logic, which is a graphical method of laying out the connectivity and logic between system inputs and outputs.

### **COUSRE OUTCOMES**

Students will

1. Understand how mechatronics system works and where it will be applied.
2. Understand how exactly Automatic Camera, Washing Machine works.

### **SELF ASSESSMENT QUESTIONS**

1. Define Mechatronics and list out advantages and disadvantages of mechatronics.
2. Draw a neat block diagram of a generalized measurement system.
3. Define control system and different types of control systems.
4. Enumerate the difference between open loop and closed loop control system.
5. With a block diagram explain the working of a microprocessor controlled washing machine.
6. With a block diagram explain the working of a microprocessor controlled automatic

camera.

7. With a block diagram explain the working of a microprocessor controlled engine management system.
8. Explain programmable logic controller.

### **FURTHER READING**

1. **Mechatronics and Microprocessors**, K.P.Ramchandran, G.K.Vijayraghavan, M.S.Balasundran, Wiley, 1st Ed, 2009
2. **Mechatronics - Principles, Concepts and applications** – Nitaigour and Premchand Mahilik Tata McGraw Hill- 2003.

## **Module 1**

### **Part 2**

## **TRANSDUCERS AND SENSORS**

### **CONTENTS**

- 2.1 Introduction
- 2.2 Definition and Classification of Transducer
  - 2.2.1 Classification of Transducer
- 2.3 Definitions and Classification of Sensors
  - 2.3.1 Classification of Sensors:
- 2.4 Light sensors:
- 2.5 Photo diodes
- 2.6 Proximity sensors:
  - 2.6.1 Eddy current proximity sensors:
  - 2.6.2 Inductive proximity Sensor:
  - 2.6.3 Optical Proximity Sensor
- 2.7 Hall Effect Sensor

### **OBJECTIVE**

- Is to understand concepts of Transducer and Sensors.
- Is to understand working of different types of sensors.

## 2.1 Introduction:

Sensors and transducers are the heart of any mechatronic system. Without sense organs there is no life and so also there is no mechatronic system without transducers and sensors. In fact, they are the essential elements of any measurement or control system.

## 2.2 Definition and Classification of Transducer:

A Transducer is a device which transforms one form of physical phenomenon or energy to another form for various purposes including measurement, control and information transfer. The physical phenomenon may be position, displacement, force, torque, flow of fluid, pressure of fluid, temperature, etc..

Transduce= Trans (Change) + Induce (Provide)

### 2.2.1 Classification of Transducer:

Transducers are classified based on the following factors:

- a. Whether the device senses and converts or just converts physical phenomenon.
- b. Method of conversion of energy.
- c. Nature and Type of output signals.
- d. Type of sensing element used.
- e. Type and nature of measurand to be used.
- f. Whether they are self generating or externally powered.
- g. Its purpose in the measurement system.

#### a. Whether the device senses and converts or just converts physical phenomenon.

**They are**

- i. Primary transducer
- ii. Secondary transducer

#### i. Primary transducer:

These are detectors which sense a physical phenomenon and convert it into an analogous output.

E. g: Thermocouple.

**ii. Secondary transducer:**

These are those which convert the analogous output of the detector, which has sensed the E.g.: Measurement of compressive force with the help of load cell.

**b. Method of conversion of energy:**

The energy or signal produced due to physical phenomenon or measurand are converted into another form using mechanical linkages as in the case of simple dial gauge or the properties of material like resistance, conduction, expansion etc.

E.g. Strain gauges are used to measure the mechanical strain of a member due to load or force. The change in resistance of the strain gauges is the measure of force.

**c. Nature and Type of output signals:**

i. Analog transducer

ii. Digital transducer

i. **Analog transducer:** These are those which convert physical phenomenon into an analogous output which is a continuous function of time. Strain gauges, thermistors, LVDT, etc, are examples of analogue transducer.

ii. **Digital transducer:** These are those which convert physical phenomenon into an electrical output which is in the form of pulses. There are not many digital transducers available, although their importance is well recognized in modern microprocessor based control systems and instrumentation. Angular digital encoder and digital level transducers are examples of digital transducers.

**d. Type of sensing element used:**

i. Elastic elements

ii. Mass sensing elements

iii. Thermal elements

iv. Hydro pneumatic elements.

**i. Elastic elements:** Most pressure measuring devices use a Bourdon tube, a bellows or a diaphragm. The action of these elements is based on elastic deformation brought about by the force resulting from pressure summation.

**ii. Mass sensing elements:** This is based on the inertia of a concentrated mass. Vibration pick up accelerometers, liquid manometers are examples of mass sensing element transducer.

**iii. Thermal elements:** these elements sense the heat of a system by indicating some change in the property of the material used, which varies with the heat.

**iv. Hydro pneumatic elements:** The two simple examples of hydro pneumatic elements are Float and hydrometer.

**e. Whether they are self generating or externally powered:**

**i. Active transducers**

**ii. Passive transducers**

**i. Active transducers:** These are those which develop their own power. They are also known as self generating transducers, the energy required for production of output signal from the physical phenomenon being measured.

E.g.: Piezoelectric pick up, thermocouples photo voltaic cell etc.

**ii. Passive transducers:** These are those which require external power for producing output signal. They are also known as externally powered transducers.

E. g. Resistance thermometer, thermostats, differential transformers etc.

**f. Its purpose in the measurement system:**

**i. Input transducers**

**ii. Output transducers**

**i. Input transducers:** These transducers convert a non electric quality into an electric signal.

E.g. Strain gauge, photovoltaic cell etc

**ii. Output transducers:** These transducers convert electrical signal back into non-electrical signal according to whether they make physical contact or not. They are contact and non-contact type.

**g. Its purpose in the measurement system:**

Mechanical transducers for measuring quantities such as position, velocity, force, torque, displacement, pressure, vibration, strain mass etc.

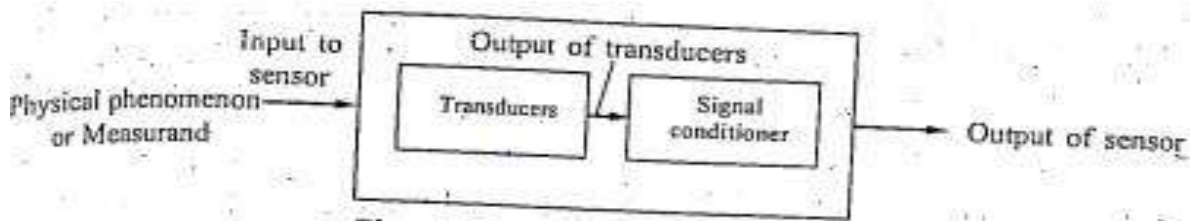


## 2.3 Definition and Classification of Sensors:

**Definition:** Sensor may be define as an element or device which can respond directly to different physical attributes such as heat, light, force related quantities etc.

The term transducer and sensor have been synonymously used although the principles are different. Transducers are physical element and are a part of sensor.

A sensor is in fact a highly refined transducer provided with signal conditioning circuit capable of modifying the signals from the transducer. The most commonly used signal conditioning circuits are amplifiers, filters, ADC, DAC, attenuators etc. Fig 2.1 shows the basic concept of sensor.



If the sensor itself transducers the physical attributes in addition to sensing is called **detector transducer**.

### 2.3.1 Classification of Sensors:

The classification of sensors are based on

#### a. Type of energy transferred, Under this we have:

- i. Thermal
- ii. Mechanical
- iii. Chemical
- iv. Optical radiation
- v. Ionizing radiation
- vi. Electromagnetic

#### b. Classification based on measurement error

#### c. Biological sensors

#### d. Geodetic sensors.

### 2.4 Light sensors:

#### Principle of Working and Applications of Light Sensors:

A light sensor is a device that is used to detect light. There are different types of light sensors such as photocell/ photo resistor and photo diodes being used in manufacturing and other industrial applications.

Photo resistor is also called as light dependent resistor (LDR). It has a resistor whose resistance decreases with increasing incident light intensity. It is made of a high resistance semiconductor material, cadmium sulfide (CdS). The resistance of a CdS photo resistor varies inversely to the amount of light incident upon it. Photo resistor follows the principle of photoconductivity which results from the generation of mobile carriers when photons are absorbed by the semiconductor material.

Figure shows the construction of a photo resistor. The CdS resistor coil is mounted on a ceramic substrate. This assembly is encapsulated by a resin material. The sensitive coil electrodes are connected to the control system through lead wires. On incidence of high intensity light on the electrodes, the resistance of resistor coil decreases which will be used further to generate the appropriate signal by the microprocessor via lead wires.

Photo resistors are used in science and in almost any branch of industry for control, safety, amusement, sound reproduction, inspection and measurement.

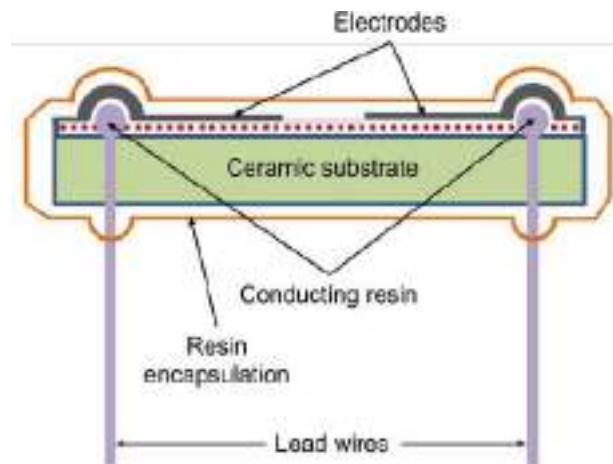


Fig 1: Construction of Light Sensors

## Applications of Light Sensor

- Computers, wireless phones, and televisions, use ambient light sensors to automatically control the brightness of a screen
- Barcode scanners used in retailer locations work using light sensor technology
- In space and robotics: for controlled and guided motions of vehicles and robots.
- Auto Flash for camera
- Industrial process control.

## 2.5 Photo diodes

Photodiode is a solid-state device which converts incident light into an electric current. It is made of Silicon. It consists of a shallow diffused p-n junction, normally a p-on-n configuration. When photons of energy greater than 1.1eV (the band gap of silicon) fall on the device, they are absorbed and electron-hole pairs are created. The depth at which the photons are absorbed depends upon their energy. The lower the energy of the photons, the deeper they are absorbed. Then the electron-hole pairs drift apart. When the minority carriers reach the junction, they are swept across by the electric field and an electric current establishes.

Photodiodes are one of the types of photo detector, which convert light into either current or voltage. These are regular semiconductor diodes except that they may be either exposed to detect vacuum UV or X-rays or packaged with a opening or optical fiber connection to allow light to reach the sensitive part of the device.

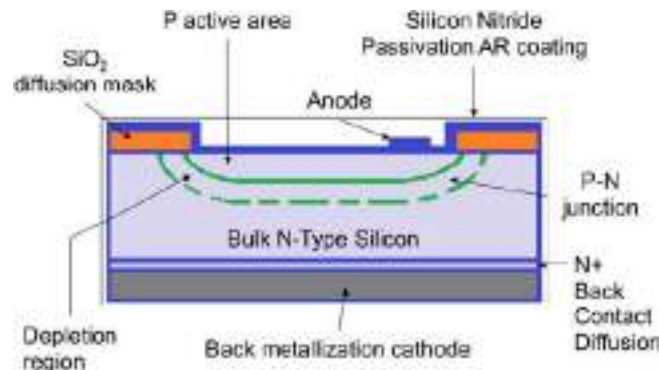


Fig 2: Construction of Photo diodes

Figure .shows the construction of Photo diode detector. It is constructed from single crystal silicon wafers. It is a p-n junction device. The upper layer is p layer. It is very thin and formed by thermal diffusion or ion implantation of doping material such as boron. Depletion region is narrow and is sandwiched between p layer and bulk n type layer of silicon. Light irradiates at front surface, anode, while the back surface is cathode. The incidence of light on anode generates a flow of electron across the p-n junction which is the measure of light intensity.

### **Applications of photo diodes**

**Camera:** Light Meters, Automatic Shutter Control, Auto-focus, Photographic Flash Control

**Medical:** CAT Scanners - X ray Detection, Pulse Oximeters, Blood Particle Analyzers.

### **Industry**

- Bar Code Scanners
- Light Pens
- Brightness Controls
- Encoders
- Position Sensors
- Surveying Instruments
- Copiers - Density of Toner

### **Safety Equipment**

- Smoke Detectors
- Flame Monitors
- Security Inspection Equipment

## 2.6 Proximity sensors:

### 2.6.1 Eddy current proximity sensors:

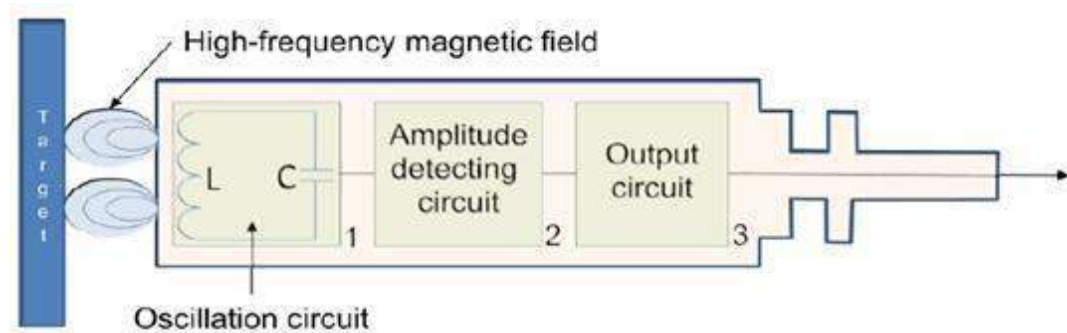


Fig 3: Construction of Eddy current proximity sensors

Eddy current proximity sensors are used to detect non-magnetic but conductive materials. They comprise of a coil, an oscillator, a detector and a triggering circuit. Figure shows the construction of eddy current proximity switch. When an alternating current is passed thru this coil, an alternative magnetic field is generated. If a metal object comes in the close proximity of the coil, then eddy currents are induced in the object due to the magnetic field. These eddy currents create their own magnetic field which distorts the magnetic field responsible for their generation. As a result, impedance of the coil changes and so the amplitude of alternating current. This can be used to trigger a switch at some pre-determined level of change in current.

Eddy current sensors are relatively inexpensive, available in small in size, highly reliable and have high sensitivity for small displacements.

#### Applications of eddy current proximity sensors:

- Automation requiring precise location
- Machine tool monitoring
- Final assembly of precision equipment such as disk drives
- Measuring the dynamics of a continuously moving target, such as a vibrating element,
- Drive shaft monitoring
- Vibration measurements

## 2.6.2 Inductive proximity Sensor:

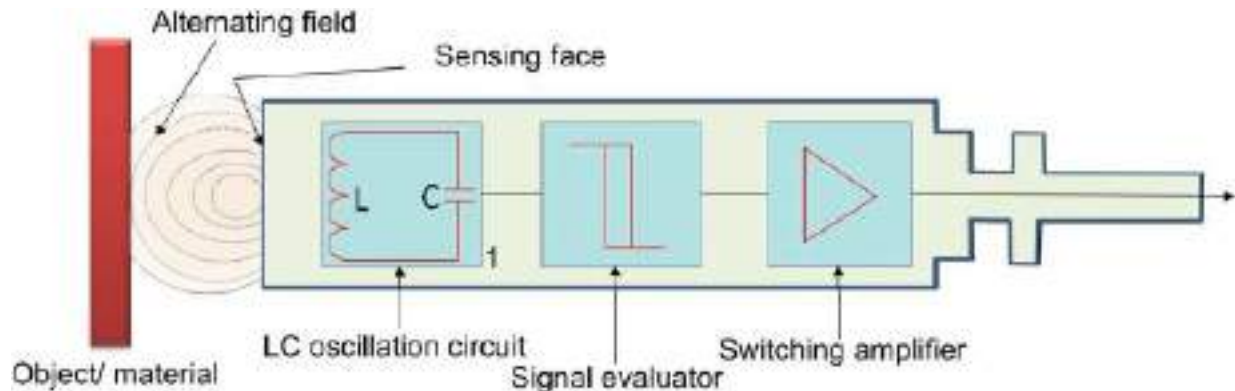


Fig 4: Schematic of Inductive proximity Sensor

Inductive proximity switches are basically used for detection of metallic objects. Figure shows the construction of inductive proximity switch. An inductive proximity sensor has four components; the coil, oscillator, detection circuit and output circuit. An alternating current is supplied to the coil which generates a magnetic field. When, a metal object comes closer to the end of the coil, inductance of the coil changes. This is continuously monitored by a circuit which triggers a switch when a preset value of inductance change is occurred.

### Applications of inductive proximity Sensor

- Industrial automation: counting of products during production or transfer
- Security: detection of metal objects, arms, land mines

## 2.6.3 Optical Proximity Sensor:

Optical encoders provide digital output as a result of linear / angular displacement. These are widely used in the Servo motors to measure the rotation of shafts. Figure shows the construction of an optical encoder. It comprises of a disc with three concentric tracks of equally spaced holes. Three light sensors are employed to detect the light passing thru the holes. These sensors produce electric pulses which give the angular displacement of the mechanical element e.g. shaft on which the Optical encoder is mounted. The inner track has just one hole which is used locate the 'home' position of the disc. The holes on the middle track offset from the holes of the outer track by one-half of the width of the hole. This arrangement provides the direction of rotation to be determined. When the disc rotates in clockwise direction, the pulses in the outer track lead those in the inner; in counter clockwise

direction they lag behind. The resolution can be determined by the number of holes on disc. With 100 holes in one revolution, the resolution would be,  $360^\circ/100 = 3.6^\circ$ .

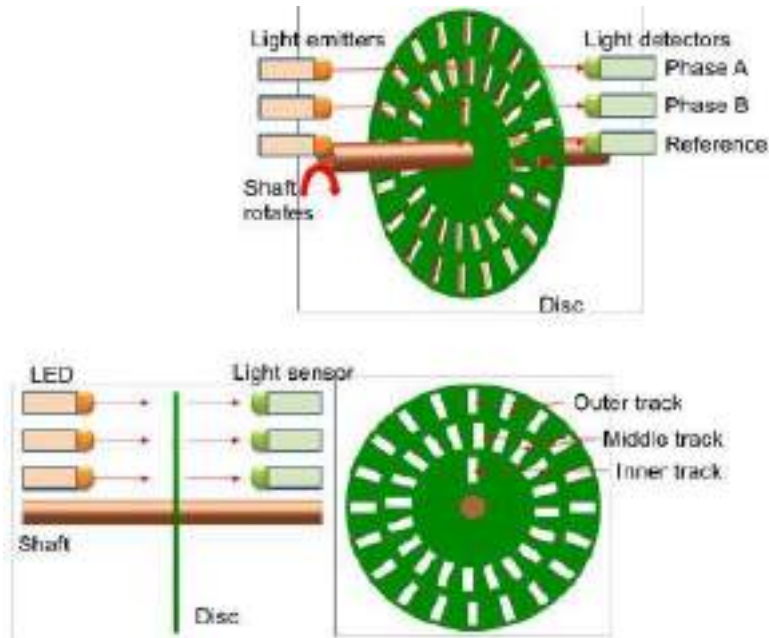


Fig 5: Construction and working principle of Optical Proximity Sensor

## 2.7 Hall Effect Sensors:

Hall Effect sensors work on the principle that when a beam of charge particles passes through a magnetic field, forces act on the particles and the current beam is deflected from its straight line path. Thus one side of the disc will become negatively charged and the other side will be of positive charge. This charge separation generates a potential difference which is the measure of distance of magnetic field from the disc carrying current.

The typical application of Hall Effect sensor is the measurement of fluid level in a container. The container comprises of a float with a permanent magnet attached at its top. An electric circuit with a current carrying disc is mounted in the casing. When the fluid level increases, the magnet will come close to the disc and a potential difference generates. This voltage triggers a switch to stop the fluid to come inside the container.

These sensors are used for the measurement of displacement and the detection of position of an object. Hall Effect sensors need necessary signal conditioning circuitry. They can be operated at 100 kHz. Their non-contact nature of operation, good immunity to environment contaminants and ability to sustain in severe conditions make them quite popular in industrial automation.

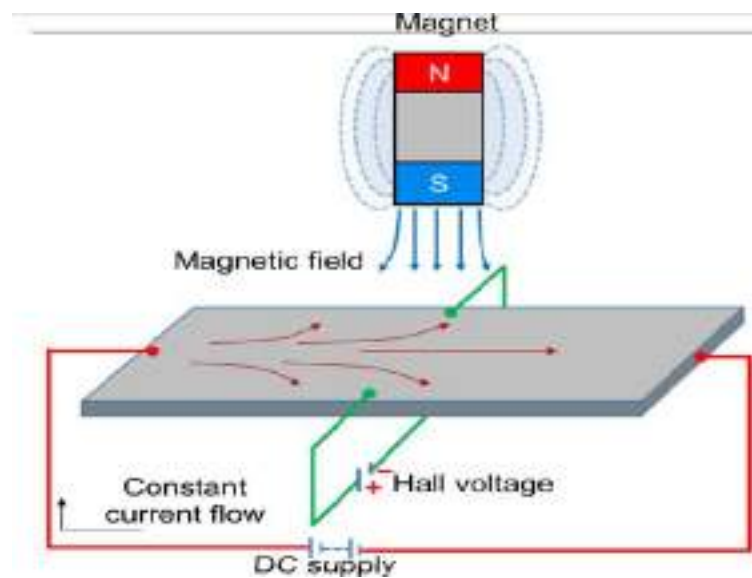


Fig 6: Hall Effect



## **COURSE OUTCOMES**

Students will

1. Learn how transducers and sensors work.

## **SELF ASSESSMENT QUESTIONS**

1. Define transducer and its classification.
2. Define sensor and its classification.
3. With an example, explain primary and secondary transducer.
4. What is an encoder and how they are classified.
5. Explain with a simple sketch the constructional features of an absolute encoder.
6. Explain with a simple sketch the constructional features of an incremental encoder.
7. Explain the principle and working of proximity sensor.
8. Explain the principle and working of Hall Effect sensor.
9. Explain the principle and working of pneumatic sensor.
10. Explain performance of a transducer.
11. Define a) range, b) span, c) sensitivity, d) accuracy.
12. Define a) hysteresis, b) resolution, c) threshold, d) system error.

## **FURTHER READING**

1. **Mechatronics Principles & applications**, Godfrey C. Onwubolu, Elsevier. .
2. **Introduction Mechatronics & Measurement systems**, David.G. Aliciatore & Michael.  
B. Bihistaned, Tata McGraw Hill, 2000.

## **Module 2: Micro-processors and Micro-controllers**

### **CONTENT:**

1. Introduction
2. Microprocessor
  - 2.1 Functions of microprocessor
  - 2.2 Elements of microprocessor
3. Microcontroller
  - 3.1 Microprocessor based programmable controller
  - 3.2 Differences between Microprocessor and microcontroller
4. Basics of microprocessor programming
  1. Number System
  2. Low Level Programming Language
5. Architecture of Microprocessor
  - 5.1 Register Array
  - 5.2 Accumulator
  - 5.3 Flags
  - 5.4 Instruction Register/Decoder
  - 5.5 Memory Address Register
  - 5.6 Control Generator
  - 5.7 Register Selector
  - 5.8 General Purpose Registers
6. Programming in 8085
  - 6.1 Classification of Instructions:

### **OBJECTIVES:**

- Is to know the knowledge of microprocessor and its functions.
- Is to know the concept of number system with conversion.

## 1. Introduction

Programmable Logic Devices (PLD) are programmable systems and are generally used in manufacturing automation to perform different control functions, according to the programs written in its memory, using low level languages of commands. There are following three types of PLDs are being employed in mechatronics systems.

- 1 Microprocessor

It is a digital integrated circuit which carries out necessary digital functions to process the information obtained from measurement system.

- 2 Microcomputer

It uses microprocessor as its central processing unit and contains all functions of a computer.

- 3 Programmable Logic Controller (PLC)

It is used to control the operations of electro-mechanical devices especially in tough and hazardous industrial environments.

A typical programmable machine has basic three components as shown in Figure 1:

1. Processor, which processes the information collected from measurement system and takes logical decisions based on the information. Then it sends this information to actuators or output devices.
2. Memory, it stores
  - 1 the input data collected from sensors
  - 2 the programs to process the information and to take necessary decisions or actions. Program is a set of instructions written for the processor to perform a task. A group of programs is called software.

1. Input/output devices: these are used to communicate with the outside world/operator.

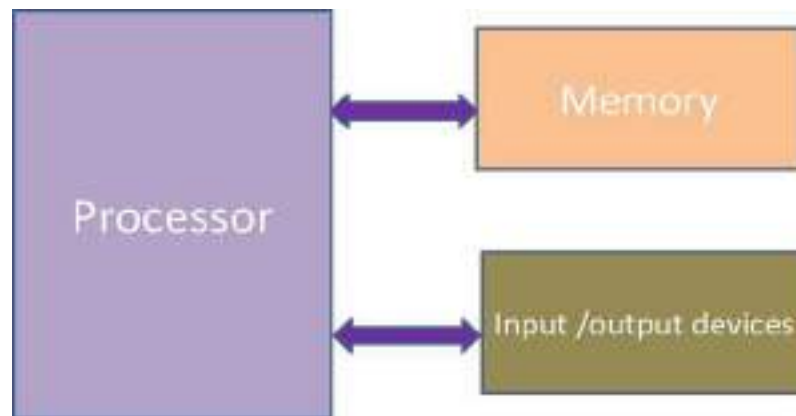


Figure 1: Components of a programmable logic device

## 2. Microprocessor

It is a multi-purpose, programmable device that reads binary instructions from a storage device called memory, processes the data according to the instructions, and then provides results as output. In common practice it is also known as CPU (central processing unit). CPU can be referred as complete computational engine on a single chip. First Microcontroller, Intel 4004 was launched in 1971. It was able to process just 4 bits. It started a new era in electronics engineering. Microprocessor chip was one of the important inventions of the 20<sup>th</sup> century. Table 1 shows the history of micro-processors.

Table 1 History of Micro-Processors

Name	Date	No. of Transistors	Width of smallest wire on chip	Clock Speed	Data Width (In Bits)	Millions of Instructions per second(MIPS)
8080	1974	6000	6	2MHz	8	0.64
8088	1979	29000	3	5 MHz	16	0.33
80286	1982	134000	1.5	6MHz	16	1
80386	1985	275000	1.5	16	32	5
80486	1989	1200000	1	25	32	20
Pentium	1993	3100000	0.8	60	32	100
Pentium II	1997	7500000	0.35	233	32	300
Pentium III	1999	9500000	0.25	450	32	510
Pentium 4	2000	42000000	0.18	1.5 GHz	32	1700

Pentium 4P	2004	125000000	0.09	3.6 GHz	32	7000
------------	------	-----------	------	---------	----	------

Applications of microprocessors are classified primarily in two categories:

1. Reprogrammable Systems : Micro computers
2. Embedded Systems : photocopying machine, Digital camera

Microprocessor works or operates in binary digits i.e. 0 and 1, bits. These bits are nothing but electrical voltages in the machine, generally 0 - low voltage level, and 1 - high voltage level. A group of bits form a 'word'. In general, the word length is about 8 bits. This is called as a 'byte'. A word with a length of 4 bits is called as a 'Nibble'

Microprocessor processes the 'commands in binary form' to accomplish a task. These are called as '*instructions*'. Instructions are generally entered through input devices and can be stored in a storage device called *memory*.

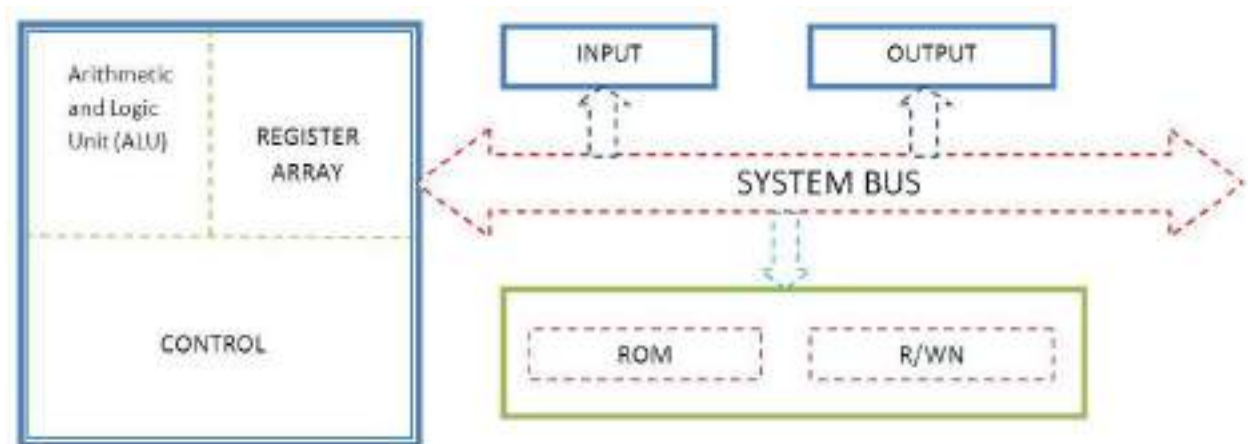


Figure 2 Schematic of configuration of a micro processor

Figure 2 and 3 show the configuration and basic blocks of a microprocessor. The functions of each element are as follows.

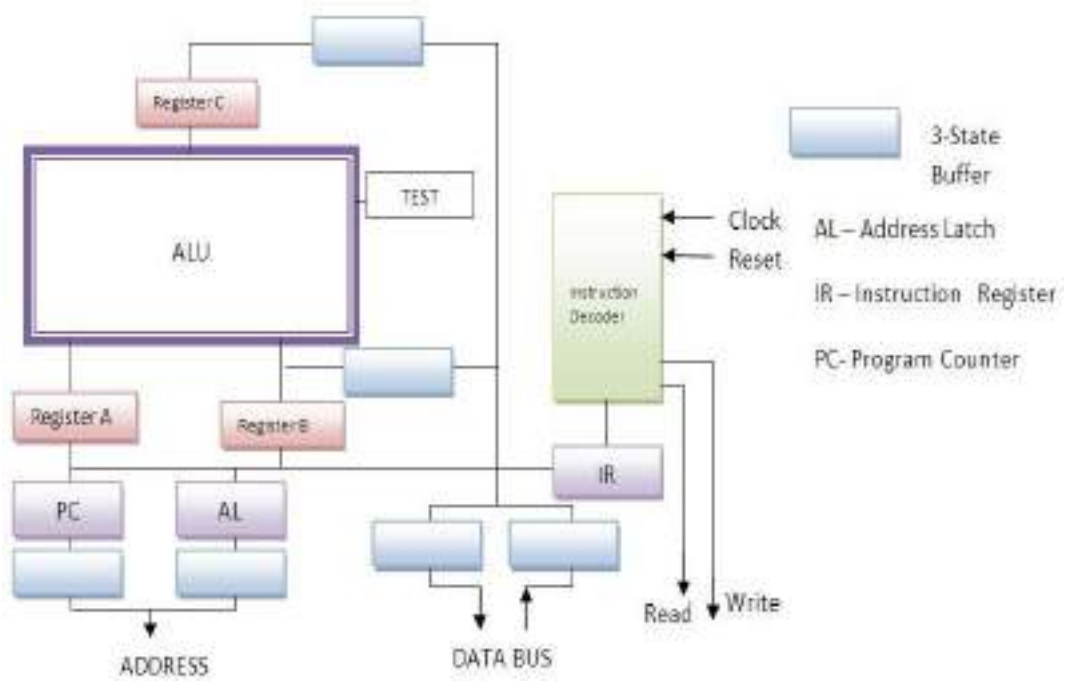


Figure 3 Working of a microprocessor

- **ALU:** ALU stands for Arithmetical Logical Unit. As name indicates it has two parts:
  - Arithmetical unit which is responsible for mathematical operations like addition, subtraction, multiplication and division,
  - Logical unit which is dedicated to take logical decisions like greater than, less than, equal to, not equal to etc. (Basically AND/OR/NOT Operations)
- **Register Array:** Registers are small storage devices that are available to CPU or processors. They act as temporary storage for processing of intermediate data by mathematical or logical operations.
- **Control:** This part of CPU is dedicated to coordinate data flow and signal flow through various types of buses i.e. Data Bus, Control Bus, and Address Bus etc. It directs data flow between CPU and storage and I/O devices.
- **Memory:** There are two different types of memory segments being used by the CPU. First is the ROM which stands for Read Only Memory while other is R/W which stands for Read and Write Memory or Random Access Memory (RAM).
  - ROM:** From this memory unit, CPU can only read the stored data. No writing operations can be done in this part of memory. Thus it is used to store the programs that need no alteration or changes like Monitor Program or Keyboard driver etc.
  - R/W:** As name indicates it is opposite to ROM and used for both reading and writing operations. In general User's program and instruction are stored in this segment of memory unit.
- **Input Devices:** Input devices are used to enter input data to microprocessor from Keyboard or from ADC which receives data from sensors/signal conditioning systems.
- **Output Devices:** These devices display the results/conclusions coming out from ALUs either in soft copy (Monitor) or in Hard Copy (Printer).

## 2.1 Functions of microprocessor

Various functions of microprocessor are as follows:

- A Microprocessor performs a variety of logical and mathematical operations using its ALU.
- B It controls data flow in a system and hence can transfer data from one location to another based on the instructions given to it.
- C A microprocessor can take necessary decisions and jump to a new set of instructions based on those decisions.

## 2.2 Elements of microprocessor

A simple microprocessor consists of following basic elements (see Figure 3):

- A Data Bus: Through data bus, the data flow between
  - o various storage units
  - p ALU and memory units
- B Address Bus: It controls the flow of memory addresses between ALU and memory unit.
- C RD (read) and WR (write) lines set or obtain the addressed locations in the memory.
- D Clock line transfers the clock pulse sequence to the processor.
- E Reset Line is used to restart execution and reset the processor to zero.
- F Address Latch is a register which stores the addresses in the memory.
- G Program Counter: It is a register which can increment its value by 1 and keeps the record of number of instructions executed. It can be set to zero when instructed.
- H Test Register: It is a register which stores intermediate or in-process data of ALU operations. For example it is required to hold the 'carry' while ALU is performing 'addition' operation. It also stores the data which can be accessed by Instruction decoder to make any decision.
- I 3-State Buffers: These are tri-state buffers. A tri-state buffer can go to a third state in addition to the states of 1 and 0.
- J The instruction register and instruction decoder are responsible for controlling the operations of all other components of a microprocessor.

There are following control lines present in a microprocessor, which are used to communicate instructions and data with the instruction decoder.

- A Instruct the A register to latch the value currently on the data bus.
- B Instruct the B register to latch the value currently on the data bus.
- C Instruct the C register to latch the value currently output by the ALU.
- D Instruct the program counter register to latch the value currently on the data bus.
- E Instruct the address register to latch the value currently on the data bus.
- F Instruct the instruction register to latch the value currently on the data bus.
- G Instruct the program counter to increment.



- o Instruct the program counter to reset to zero.
- p Activate any of the six tri-state buffers (six separate lines).
- q Instruct the ALU what operation to perform.
- r Instruct the test register to latch the ALU's test bits.
- s Activate the RD line.
- t Activate the WR line

### 3. Microcontroller

Microcontroller is a microprocessor based system. It is a data processing system that employs a microprocessor as its central unit. Based on the input it takes decisions. These decisions are further used to control a system or to actuate an action or operation.

#### 3.1 Microprocessor based programmable controller

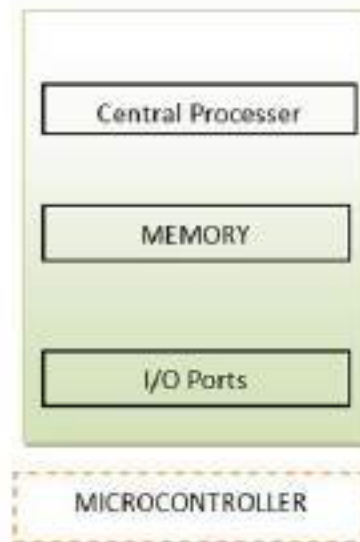


Figure 4 Schematic of microcontroller.

It is a microprocessor-based system. It implements the functions of a computer and a controller on a single chip. Generally microcontroller is programmed for one specific application and it is dedicated to a specific control function.

Microcontrollers find applications in automobiles, aircraft, medical electronics and home appliances. They are small in size and can be embedded in an electromechanical system without taking up much space. Thus we can have a system with its functions completely designed into a chip. However microcontrollers have very little user programmable memory. Various types of microcontroller chips available in market are: Motorola 68HC11, Zilog Z8 and Intel MCS51 and 96 series.

### 3.2 Differences between Microprocessor and microcontroller

The differences are listed below and are considered as a major distinguishing parameters between the two

Table 2: Microprocessor and microcontroller comparison

<b>Microcontroller</b>	<b>Microprocessor</b>
Micro Controller is a heart of the embedded system	The microprocessor is the heart of Computer system
Microcontroller has an external processor along with internal memory and input/output components	It is just a processor. Memory and I/O components have to be connected externally
Since memory and I/O are present internally, the circuit is small.	Since memory and I/O has to be connected externally, the circuit becomes large
The cost of the entire system is low	Cost of the entire system increases
The microcontroller has a number of registers, hence the programs are easier to write	Microprocessor has less number of registers, hence more operations are memory based
Used mainly in the washing machine, MP3 players	Mainly used in personal computers

## 4. Basics of microprocessor programming

In this lecture we will study the various number systems, programming languages, and internal architecture of the basic microprocessor, 8085.

### 4.1. Number System

Number system is a way of representing the value of any number with respect to a base value. Number System can be classified on the basis of its “base”. Each number has a unique representation in a number system. Different number systems have different representation of the same number. In general Binary, Octal, Decimal and Hexadecimal Number systems are used in microprocessor programming. Table 3 shows different numbering systems and their details.

Table 3: Numbering systems

Number System	Base	Allowable Digits/Characters	Examples
Binary	2	0,1	(11001010001010) <sub>2</sub>
Octal	8	0,1,2,3,4,5,6,7	(5671235246214) <sub>8</sub>
Decimal	10	0,1,2,3,4,5,6,7,8,9	(9823654178523) <sub>10</sub>
Hexadecimal	16	0,1,2,3,4,5,6,7,8,9,A,B,C,D,E,F	(A852F6DB) <sub>16</sub>


### 1.1 Number representation

#### 1.1.1 Conversion of any number system to decimal number system:

Let B be the base of number system and  $A_n, A_{n-1}, \dots, A_1, A_0$  be the digits of given number. Then to convert it into decimal equivalent we can use the following formula:

$$N = A_n \cdot B^n + A_{n-1} \cdot B^{n-1} + \dots + A_1 \cdot B + A_0 \cdot B^0$$

Example: what is the decimal equivalent of  $(11101011)_2$  ?

 Here, we have taken  $A_n = 1, A_{n-1} = 1, \dots, A_{n-3} = 0$ , while  $n=8$  and  $B$

$= 2$ . Then the decimal equivalent is  $(235)_{10}$ .

### 1.1.2 Decimal number system to any number system:


Any number in decimal system can be changed to any other number system by continuously dividing it by base of the required number system and then writing remainders after each step in reverse order.

Let us take an example of converting a decimal number 235 to its binary equivalent.

Following table shows the conversion process as stated above.

**Table 3: Binary representation of  $(235)_{10}$**

2	235	1
2	117	1
2	58	0
2	29	1
2	14	0
2	7	1
2	3	1
2	1	1



→ Hence Binary equivalent of  $(235)_{10}$  is  $(11101011)_2$ .

### 1.1.3 Hexadecimal system:

This system is quite extensively used in microprocessor programming. It facilitates much shorter representation of number in comparison with that obtained by using the binary number system. Hexadecimal system has a base of 16 and it is easy to write and remember the numbers and alphabets viz. 0 to 9 and A to F. Table 4 shows numerals and alphabets used in hexadecimal system for representation of a number.

**Table 4 Numerals and alphabets used in hexadecimal system**

Decimal	Binary	Hexadecimal
0	0000	0
1	0001	1
2	0010	2
3	0011	3
4	0100	4
5	0101	5
6	0110	6
7	0111	7
8	1000	8
9	1001	9
10	1010	A
11	1011	B
12	1100	C
13	1101	D
14	1110	E
15	1111	F

Example: Let us convert the number  $(235)_{10}$  to hexadecimal equivalent. Table 5 shows the conversion of this decimal number.

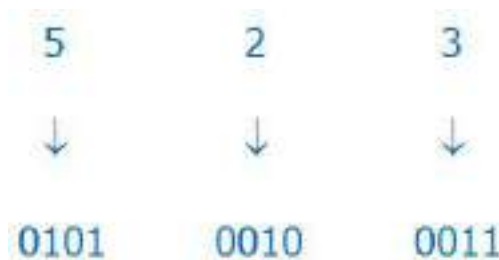
**Table 5 Decimal to hexadecimal conversion**

<u>Number</u>	<u>Division</u>	<u>Remainder</u>	<u>Hexadecimal equivalent of remainder as per table 3.2.3</u>
<u>235</u>	<u>235 divided by 16 = 14 (full)</u>	<u>11</u>	<u>B</u>
<u>14</u>	<u>14 divided by 16 = Cannot divide</u>	<u>14</u>	<u>E</u>

Then by arranging the hexadecimals in reverse order i.e. **(EB)<sub>16</sub>**. Thus  $(235)_{10} = (EB)_{16}$ .

#### 1.1.4 Binary coded decimal (BCD)

BCD code expresses each digit of a decimal system by its nibble equivalent. It uses 4 bit binary strings to represent the digits 0 to 9. Figure 5 shows the representation of number 523 as 01010010011 using BCD system. Due its longer representation scheme, it is now rarely used in micro-electronics programming.



**Figure 5 BCD representation system**

Example:  $(235)_{10}$  can be represented by using PCD as 001000110101.

## 4.2. Low Level Programming Language

Microprocessors recognize the binary numbers and they operate in binary numbers. Each microprocessor has its own binary words, meanings and languages. Each machine has its own set of instructions based on the design of its CPU. Binary language is called as *machine language*. English-like words are used to represent the binary instructions of a machine. This is called as *assembly language* programs. The general purpose languages such as BASIC, FORTRAN, C, etc. are called as *high-level languages*. The *machine language* and *assembly language* are however specific to a microprocessor, therefore these are termed as low-level languages.

### 4.2.1 Assembly language

In assembly language, a word length is of about eight bits. It is called as a *byte*. Assembly language can have 256 combinations of bytes. Thus the language has 256 words. There can be a various patterns of bytes. With the help of electronic logic gates, these patterns give a specific meaning to each combination of bytes. These are called as an '*instruction*'. Instructions are made up of one word or several words. The set of instructions designed into the machine makes up the *machine language* that is specific to each microprocessor based system viz. micro-computer.

Thus we can say,

'Machine language is the binary medium of communication through a designed set of instructions specific to each computer.'

'Assembly level language is a medium of communication with a computer in which programs are written in mnemonics. An assembly language is specific to a given computer.'

### 4.2.2 Assembly language programming

Assembly language programming is generally written by using hexadecimal codes. Programs can be written by using special keyboard equipped with using hex keys. Programs also have instructions to translate these keys into their equivalent binary patterns. The data and instructions are stored in prescribed locations in memory. An operation code is written which accomplishes the intended task(s). These tasks are carried out on 'operand(s)' by the operation code. 8085 is a typical general purpose microprocessor and has 8-bit word length. Now, let us learn its architecture, working and programming.

## 5. Internal Architecture of 8085 Microprocessor

### 5.1 Register Array

8085 Microprocessor consists of six registers, one accumulator and a flag register. The typical architecture is shown in figure 6. There are six general-purpose registers B, C, D, E, H, and L, each having capacity to store 8 bit data. They are combined as BC, DE, HL to perform 16 bit operations. In addition to this Register array, two 16 bit registers viz. stack register and program counter are provided. As discussed in the earlier lecture, the 'program counter' is employed to sequence the execution of instructions. It always points to the memory address from which the next byte is to be fetched. Stack Pointer points to the memory location in R/W (Read and/or write) memory. It is also termed as a 'stack'.

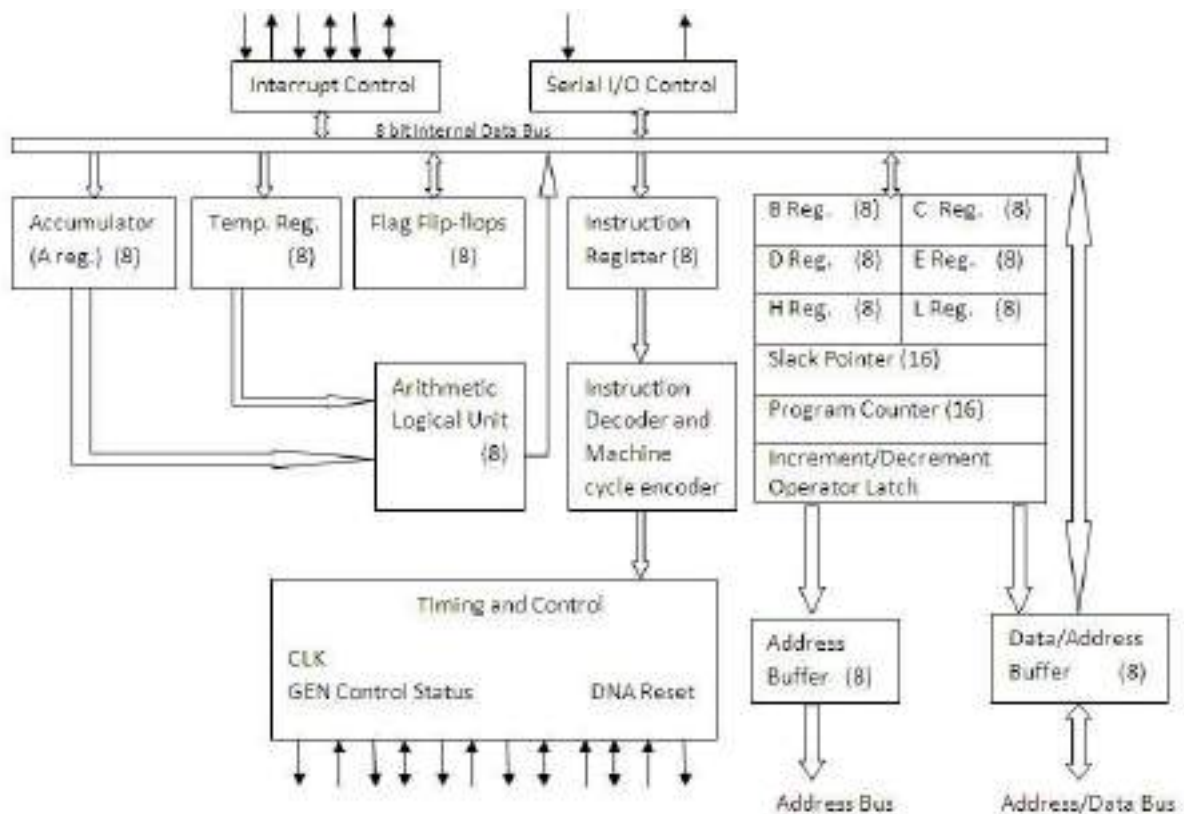


Figure 6 Architecture of 8085 microprocessor



## 5.2 Accumulator

The accumulator is 8-bit register (can store 8 bit data). It is a part of arithmetic/logic unit (ALU). In general, after performing logical or arithmetical operations, result is stored in accumulator. Accumulator is also identified as Register A.

## 5.3 Flags

ALU of 8085 have five flip flops whose states (set/reset) are determined by the result data of other registers and accumulator. They are called as Zero, Carry, Sign, Parity and Auxiliary-Carry flags.

- A Zero Flag (Z): When an arithmetic operation results in *zero*, the flip-flop called the Zero flag - which is set to one.
- B Carry flag (CY): After an addition of two numbers, if the sum in the accumulator is larger than eight bits, then the flip-flop uses to indicate a *carry* called the Carry flag – which is set to one.
- C S-Sign (S): It is set to 1, if bit D7 of the result = 1; otherwise reset. D7 is the first digit of a binary number.

D7	D6	D5	D4	D3	D2	D1	D0
S	Z		AC		P		CY

- A P-Parity (P): If the result has an even number of 1s, the flag is set to 1; for an odd number of 1s the flag is reset.
- B AC-Auxiliary Carry (AC): In an arithmetic operation, when a carry is generated by digit D3 and passed to digit D4, the AC flag is set. Generally this flag is used internally for Binary Coded Decimals (BCD).

Figure 3.2.2 shows a 8-bit flag register, adjacent to the accumulator. It is not used as a register. Out of eight bit-positions, five positions are used to store the outputs of five flip-flops. These flags play an important role in decision-making process of the microprocessor.

## 5.4 Instruction Register/Decoder

Before execution of an instruction, it is sent to the Instruction Register. Instruction register stores current instruction of any program. Decoder takes the instruction from memory, decodes it and then passes it to the next stage.

## 5.5 Memory Address Register

Memory Address Register (MAR) holds the address of next instruction to be executed.

## 5.6 Control Generator

In microprocessor, the Control Generator generates a signal that executes the operations in accordance to the decoded instructions. In fact it creates a signal (information) which have details about connections between different blocks of the microprocessor so that data reaches to the respective place.

## 5.7 Register Selector

Register selector is basically a logical controller which directs switching between different registers of microprocessor.

## 5.8 General Purpose Registers

Microprocessor has few extra registers which can be used to store additional data during a program.

## 6. Programming in 8085

As mentioned in above section, a simple and very effective substitution to binary codes could be use of standard English words to complete any task. For example addition of two numbers can be represented by ADD. Such codes are referred as *mnemonic codes* and that language is called *assembly language*. Most of the early processers including 8085, are programmed using *mnemonics*. However, assembly language codes should be converted into binary one so that microprocessor can identify the instructions given to it. This operation is done by Assembler. In assembly language, instructions are composed of two segments which are as follows:

- C. Operation (Op) Code: It depends on which operation is to be performed. For example for OR operation, we have Op Code “OR”.
- D. Operands: Operand is the object on which the required operation is to be done. Generally operations are done on data stored in registers.

### 6.1 Classification of Instructions:

- A Data Transfer
- B Arithmetic
- C Logical
- D Program Control

### 6.1.1 Data Transfer

1. Load: It reads content from specified memory location and copies it to specified register location in CPU.
2. Store: It copies content of a specified register into specified memory location.

### 6.1.2 Arithmetic:

- A Add: It adds contents of a specified memory location to the data in some register.
- B Decrement: It subtracts 1 from contents of specified location.
- C Compare: It tells whether contents of a register are greater than, less than or same as content of specified memory location.

### 6.1.3 Logical:

- AND: Instruction carries out Logical AND operation with the contents of specified memory location and data in some register. Numbers are *ANDed* bit by bit.
- OR: Instruction carries out Logical OR operation with the contents of specified memory location and data in some register. Numbers are *ORed* bit by bit.
- Logical Shift: Logical shift instruction involves moving a pattern of bits in the register one place to left or right by moving a zero in the end of number.

### 6.1.4 Program Control:

- Jump: This instruction changes the sequence in which program steps are carried out. Normally program counter causes the program to be carried out sequentially in strict numerical sequence. However, JUMP causes program counter to some other specified location in the program.
- Branch: This is a conditional instruction which might 'branch' if 'zero' results or 'branch' if 'plus' results of an operation. Branch also followed if right conditions occur in the decision making process.
- Halt: This instruction stops all further microprocessor activity.

## **COURSE OUTCOME**

Students will

1. Understand how exactly a processor works internally and the concepts of different parameters included in 8085 processor.
2. Learn the difference between microprocessor and microcontroller.
3. Know how codes are represented with characters.

## **SELF ASSESSMENT QUESTIONS**

1. With a neat block diagram explain Intel 8085A microprocessor architecture.
2. Explain different register present in a control unit.
3. Draw the flow diagram of instruction cycle.
4. Explain the concept of read cycle and write cycle.
5. Explain the main features and functions of data bus.
6. What is microcontrollers and explain its classification?
7. Enumerate the difference between microprocessor and microcontroller.
8. Enumerate the difference between RISC and CISC.

## **FURTHER READING**

1. Mechatronics and microprocessor, Dr H.D.Ramachandra, Sudha Publications, Bangalore, 2016

## **Module 3: Programmable Logic Devices (PLDs) and Integration**

### **CONTENTS**

#### **Programmable logic controller**

- 3.1 Introduction to PLC's,
- 3.2 Basic structures
- 3.3 Principle of operation
- 3.4 Programming and concept of ladder diagram
- 3.5 Concepts of latching and selection criteria for PLC's

#### **Integration**

- 3.6 Introduction & background
- 3.7 Advanced actuators and Pneumatic actuators
- 3.8 Industrial Robot
- 3.9 Different parts of a Robot-Controller
- 3.10 Drive, Arm, End Effectors, Sensor
- 3.11 Functional requirements of robot

#### **OBJECTIVE**

- Is to understand concepts of Programmable Logic Controllers.
- Is to understand working of different actuators and robots.

### 3.1 Introduction to PLC's

Any computer having input and output interfaces can be used to control external devices. However most of the computers are not industrially hardened. Input / Output devices of general-purpose microcomputers are not engineered to handle line-voltages and currents above transistor-transistor logic (TTL) levels. Also they are not designed to with-stand the temperature, humidity, and vibration on shop floors. These drawbacks of a general purpose computer have been rectified by developing a Programmable Logic Controller (PLC) with built-in isolation into their inputs and outputs.

“The programmable logic controller is defined as a digital electronic device that uses a programmable memory to store instructions and to implement functions such as logic, sequencing, timing, counting and arithmetic words to control machines and processes.”

PLCs are generally used for incorporating automation in open loop systems where processes are to be performed in a sequential manner. PLCs are used for automation of assembly lines in industries. They are generally designed for multiple input multiple output (MIMO) systems. In PLCs, instructions are saved in nonvolatile memory. Some of the advantages of PLCs are:

- Cost effective
- Flexibility and ability to use similar system for other processes
- Programming interface is easier in comparison to other processors
- Resistant to impact and vibration
- Resistant towards electrical and mechanical noise
- Ability to work at high temperatures

Now let us study the structure and functioning of a PLC.

### 3.2. Basic structures

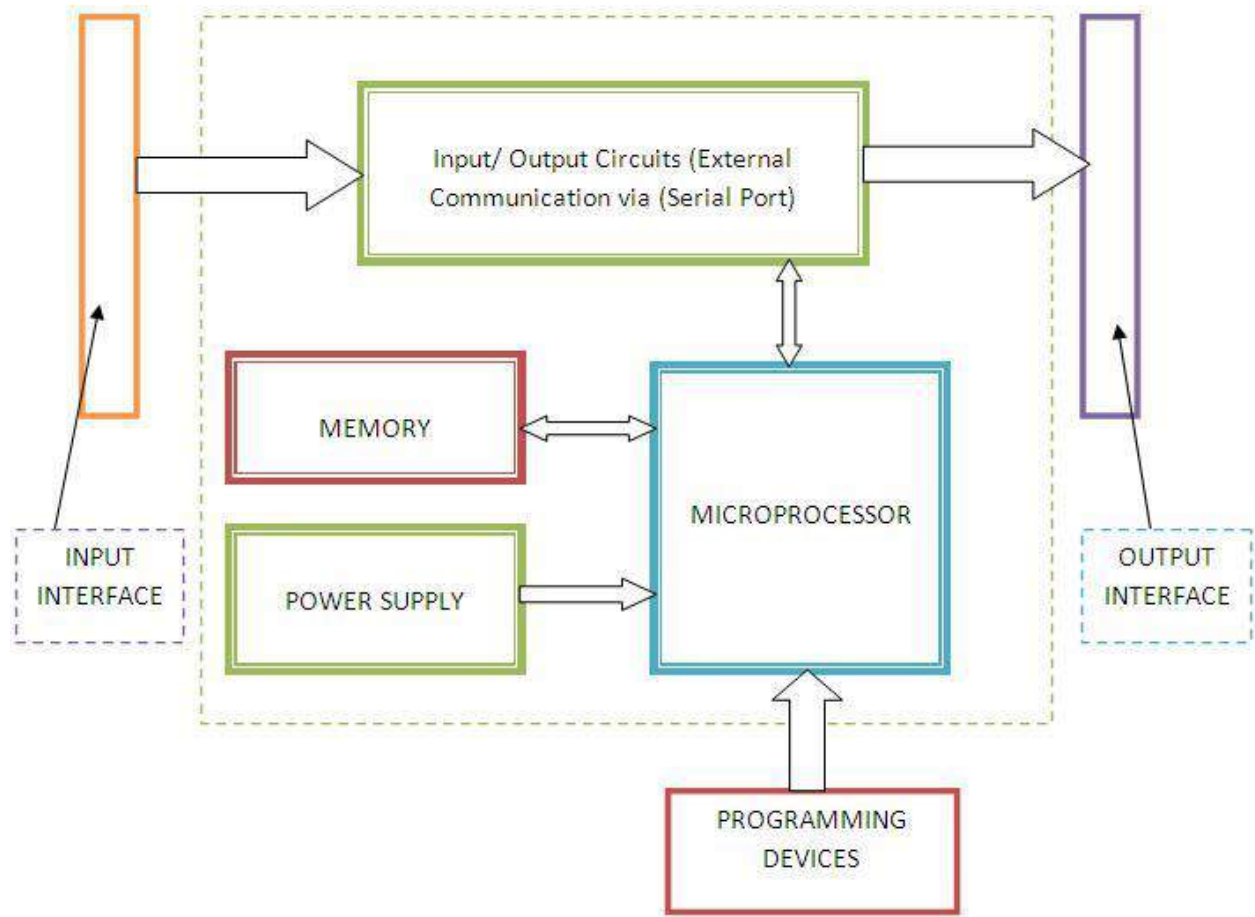


Figure 3.2.1 Block diagram of a PLC

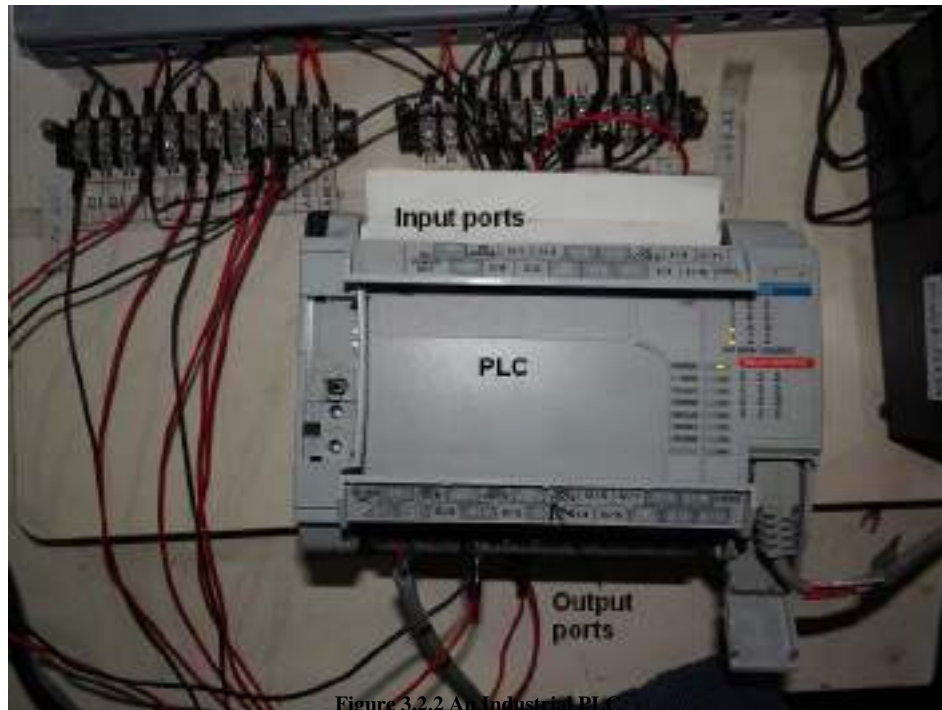


Figure 3.2.2 An Industrial PLC

Figure 3.2.1 shows the basic elements of a PLC. It is basically a microprocessor based control system. Microprocessor communicates with the outside world with input/output devices via a circuitry. This circuitry protects the microprocessor and other elements of PLC from the high voltages and currents coming to the PLC. Microprocessor does its basic functions of taking decisions according to the instructions written in the programs which are stored in the memory. PLC scans a set of sensor inputs rapidly and repeatedly. Then it evaluates their logic relationships to defined outputs according to a logic program. At last it sets the outputs according to the programmed logic. Figure 3.2.2 shows an industrial PLC with input and output ports.

### 3.3 Principle of operation

PLCs are programmed through concept of ladder logic. In general there exists a graphical user interface (GUI) to program a PLC that makes it different from other processors. Ladder logic comprises of two columns. Left column shows input devices like switches, sensors while in output column is at right side which shows actuators like cylinders, motors.



## Meanings of symbols used in PLC Program:

[[

This instruction is called as “examine on” or “normally opened” as input functions or storage bits. If the corresponding memory bit is a “1” then the respective ‘rung’ will continuously be executed and the corresponding outputs will be energized. Rung is one of the multiple horizontal programming lines in a ladder logic diagram.

NOTE: Other factors may also affect rung simultaneously.

If the corresponding bit is “0” then the rung will not be executed continuously and outputs will be de-energized. If this instruction is used as input bit, its status should be according to the status of the real world input devices connected to the input table by identical addresses.

### Addressing Sample: I: 3/1

This indicates address of a sample. I indicates input image table, 3 indicates slot no. 3 of input port and 1 indicates bit three of 3<sup>rd</sup> slot of input port.

[/

This instruction is called “examine off” or “normally closed” as input functions or storage bits. If the corresponding memory bit is a “1” then the respective ‘rung’ will continuously be executed and the corresponding outputs will be energized.

NOTE: Other factors may also affect this rung simultaneously.

If the corresponding bit is “0” this instruction will not allow rung continuously and outputs will be energized. If used as input bit, its status should correspond to the status of the real world input devices tied to the input table by identical addresses.

**O**T**E** → ( ) →

This is called as ‘output energize’. This instruction sets the specified bit when rung continuity is achieved. Under normal operating conditions, if the set bit corresponds to an output device, output device will be energized when rung goes true.

### Addressing Example O:3/1

O -- output image table

3 -- slot three

1 -- bit one of slot three

**OTL → -(L)-**

This is called as ‘output latch’. This instruction functions similar to output energize except that once a bit is set with OTL, it is latched on. Once an OTL bit has been set ON (1 on the memory) it will remain ON even if the rung condition goes false. The bit must be reset.

**(U)**

This is called as ‘output unlatch’. This is used to unlatch (reset) a latched bit. Its address must be same as latched one.

**Timer**

This is also called as “TON”. Figure 3.3.3 shows the schematic of a Timer. It is used to turn an output ON or OFF after the timer has been ON for preset time interval. This output instruction begins timing when rung goes true. It waits the specified amount of time (As specified in Preset), keeps track of accumulated intervals which have occurred (ACCUM), and sets DN (Done) bit when ACCUM time equals preset time.

As long as rung condition remains true, Timer adjusts its accumulated value to each evaluation until it reaches the preset value. The accumulated value is reset when rung condition go false, regardless of whether timer has timed out. ” TIME BASE” is an amount of time after which accumulator increases its value by 1.

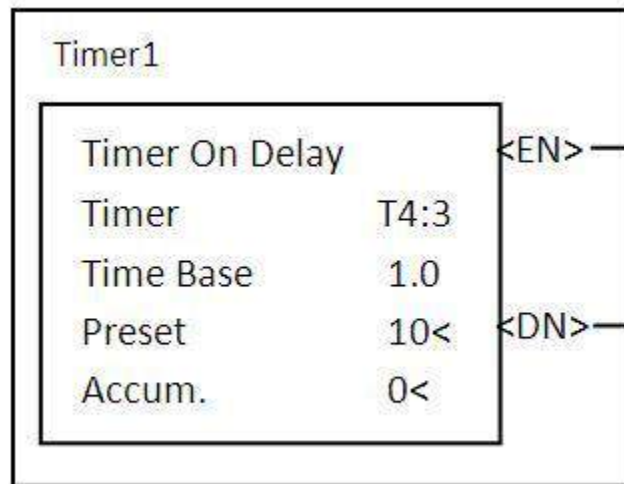


Figure 3.3.3 Schematic of a Timer

### 3.4 Programming and concept of ladder diagram

In this segment, we will see how PLCs are incorporated to control various activities in an industry. In this illustration we have a conveyor belt run with two motors at its ends, three different stations to perform various activities like painting of vehicle body or fitting of any component in chassis etc along with two switches to run conveyer. Figure 3.3.4 shows the photograph of a conveyor belt system. The PLC is of “Bull 1764 Micrologix 1500 LSP Series C” which can be controlled by a Graphical User Interface “RS Logic 500 Starter”.

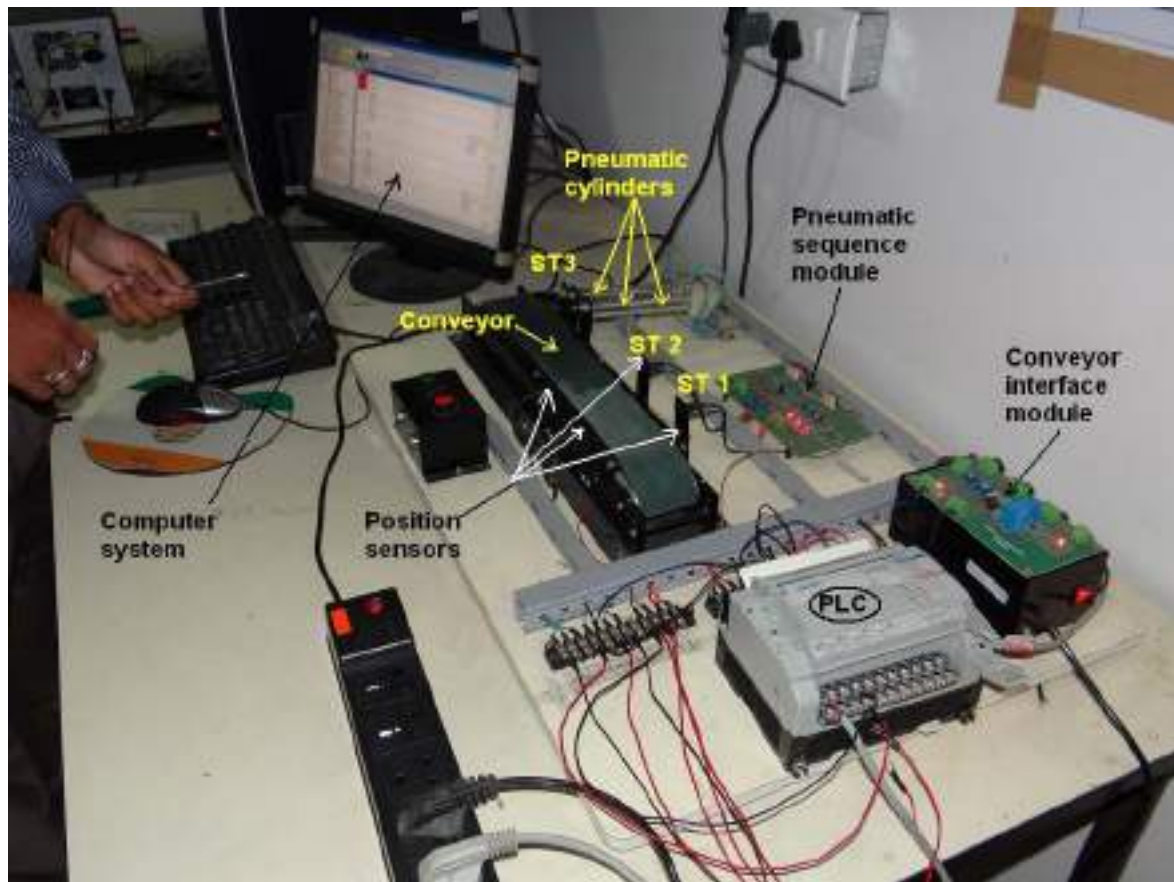


Figure 3.3.4 PLC controlled conveyor belt system

### To run the conveyer belt with the help of switches

As discussed in earlier sections, PLCs are controlled through Ladder Logic. In input section of the ladder, name of the input device must be mentioned on the top of symbol, followed by primary input port. Secondary input port is mentioned just below symbol. In similar way, output symbol should be mentioned with name and output ports as shown in figure 3.3.5.

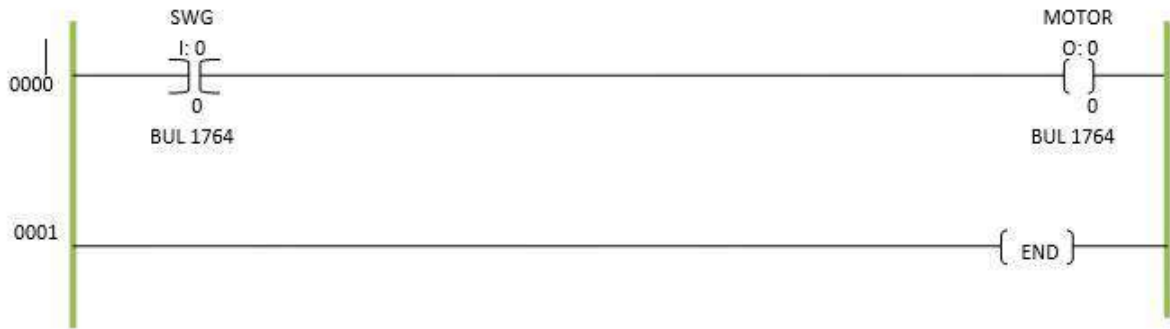


Figure 3.3.5 A rung to run the conveyer belt.

### To control movement of pneumatic devices in an industry with PLCs

Figure 3.3.6 shows a program code to control the motion of pneumatic cylinder with a switch.



Figure 3.3.6 Program code to actuate a pneumatic cylinder

### 3.5 Concepts of latching

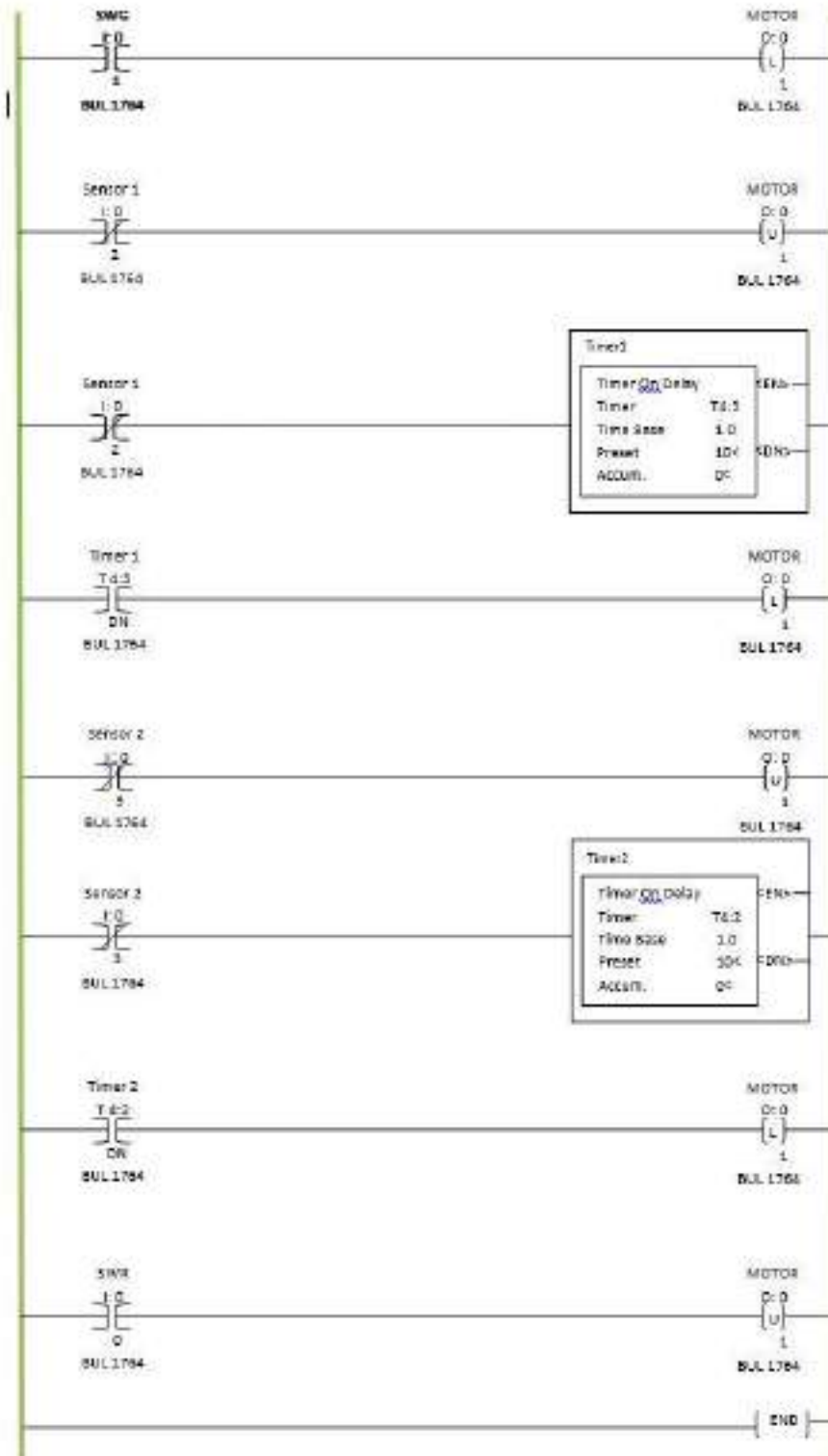


Figure 3.3.7 Program code to make use of sensors and actuators

In industrial applications, it is required to use various sensors to control the operations of systems and processes using PLCs. Figure 3.3.7 shows a typical program to operate an electric motor and a pneumatic cylinder with the help of some sensors such pneumatic proximity switch.

To control a mechatronics system we need to combine various mechanical and electrical input and output devices and to operate them in a sequential manner. Consider a prototype of industrial assembly line with 3 stations as shown in Figure 3.3.4.

At first station ST1, the sensor identifies an object (finished product) on the conveyer belt and sends a signal to the controller. Controller processes this information and actuates the electric motor to run the conveyer belt.

Second Station ST2: It is allotted for the inspection of the finished product or object. At ST2, conveyer belt stops. In case any fault diagnosed by the inspection system, the product will be taken away by the pneumatic actuators placed at Station 3, ST3.

### PLC selection criteria consist of:



#### System requirements

- \* The starting point in determining any solution must be to understand what is to be achieved.
- \* The program design starts with breaking down the task into a number of simple understandable elements, each of which can be easily described.

#### Application requirements

- \* Input and output device requirements. After determining the operation of the system, the next step is to determine what input and output devices the system requires.
- \* List the function required and identifies a specific type of device.
- \* The need for special operations in addition to discrete (On/Off) logic.
- \* List the advanced functions required beside simple discrete logic.

#### Electrical Requirements

The electrical requirements for inputs, outputs, and system power; when determining the electrical requirements of a system, consider three items:

- Incoming power (power for the control system);
- Input device voltage; and
- Output voltage and current.

### **Speed of Operation**

How fast the control system must operate (speed of operation).

When determining speed of operation, consider these points:

- How fast does the process occur or machine operate?
- Are there “time critical” operations or events that must be detected?
- In what time frame must the fastest action occur (input device detection to output device activation)?
- Does the control system need to count pulses from an encoder or flow-meter and respond quickly?

### **Communication**

Communication involves sharing application data or status with another electronic device, such as a computer or a monitor in an operator’s station. Communication can take place locally through a twisted-pair wire, or remotely via telephone or radio modem.

### **Operator Interface**

In order to convey information about machine or process status, or to allow an operator to input data, many applications require operator interfaces. Traditional operator interfaces include pushbuttons, pilot lights and LED numeric display. Electronic operator interface devices display messages about machine status in descriptive text, display part count and track alarms. Also, they can be used for data input.

### **Physical Environment**

The physical environment in which the control system will be located considers the environment where the control system will be located. In harsh environments, house the control system in an appropriate IP-rated enclosure. Remember to consider accessibility for maintenance, troubleshooting or reprogramming

---

## 3.6 Introduction & background

**Basic Concepts of Actuators** An actuator is something that actuates or moves something. More specifically, an actuator is a device that converts an input energy into motion or mechanical energy. The input energy of actuators can be “manual” (e.g., levers and jacks), hydraulic or pneumatic (e.g., pistons and valves), thermal (e.g., bimetallic switches or levers), and electric (e.g., motors and resonators). In the transducers unit, a transducer was defined as any device that converts one form of energy to another form of energy; therefore, by that definition, an actuator can be a specific type of a transducer. The motor is one such actuator. A motor converts electrical energy to mechanical energy; therefore, a motor is both an actuator and a transducer.

## 3.7 Advanced actuators and Pneumatic actuators

**Mechanical Actuator:** In mechanical actuators normally a rotary motion is converted into linear motion to perform an operation. Such actuator normally involves gears, rails, pulley, chain, springs etc to operate. The most Common example is Main engine pneumatic actuator for changing of Roller Position over cam shaft for reversing.

**Hydraulic Actuator:** Unlike air, liquid cannot be compressed and hence hydraulics generates higher energy than any other system. All systems involving high loads are operated by hydraulic actuators in which oil pressure is applied on mechanical actuator to give an output in terms of rotary or linear motion. Basic example is [steering gear](#) of ship in which hydraulic pressure is used to move the rudder actuator.

**Electrical Actuator:** It is one of the cleanest and readily available forms of actuating system as it does not involve oil; as there is no need to compress air, hence no extra machinery. Electrical energy is always available on ship. The electrical energy is used to actuate a mechanical system using magnetic field i.e. EMF. Basic example are electrical motor operated valve and magnetic valve actuator or solenoid valve. In solenoid valve the electrical signal which will magnetize the upper portion of the valve, which will then attract the valve seat and open the system. When electrical supply is removed, valve gets shut by spring action.



**Hybrid Actuators:** These are mixture of some of the above systems which control the mechanical part of the system. Common example is a thermo hydraulic Electronic actuator used in operating valves in hot water system, wherein hot water liquid is used along with electronic system acting as control for the valve



### 3.8 Industrial Robot

An industrial robot is a general-purpose, programmable machine. It possesses some anthropomorphic characteristics, i.e. human-like characteristics that resemble the human physical structure. The robots also respond to sensory signals in a manner that is similar to humans. Anthropomorphic characteristics such as mechanical arms are used for various industry tasks. Sensory perceptive devices such as sensors allow the robots to communicate and interact with other machines and to take simple decisions. The general commercial and technological advantages of robots are listed below:

- Robots are good substitutes to the human beings in hazardous or uncomfortable work environments.
- A robot performs its work cycle with a consistency and repeatability which is difficult for human beings to attain over a long period of continuous working.
- Robots can be reprogrammed. When the production run of the current task is completed, a robot can be reprogrammed and equipped with the necessary tooling to perform an altogether different task.
- Robots can be connected to the computer systems and other robotics systems. Nowadays robots can be controlled with wire-less control technologies. This has enhanced the productivity and efficiency of automation industry.

### 3.9 Different parts of a Robot-Controller

The manipulator of an industrial robot consists of a series of joints and links. Robot anatomy deals with the study of different joints and links and other aspects of the manipulator's physical construction. A robotic joint provides relative motion between two links of the robot. Each joint, or axis, provides a certain degree-of-freedom (dof) of motion. In most of the cases, only one degree-of-freedom is associated with each joint. Therefore the robot's complexity can be classified according to the total number of degrees-of-freedom they possess.

Each joint is connected to two links, an input link and an output link. Joint provides controlled relative movement between the input link and output link. A robotic link is the rigid component of the robot manipulator. Most of the robots

are mounted upon a stationary base, such as the floor. From this base, a joint-link numbering scheme may be recognized as shown in Figure 3.5.1. The robotic base and its connection to the first joint are termed as link-0. The first joint in the sequence is joint-1. Link-0 is the input link for joint-1, while the output link from joint-1 is link-1—which leads to joint-2. Thus link 1 is, simultaneously, the output link for joint-1 and the input link for joint-2. This joint-link-numbering scheme is further followed for all joints and links in the robotic systems.

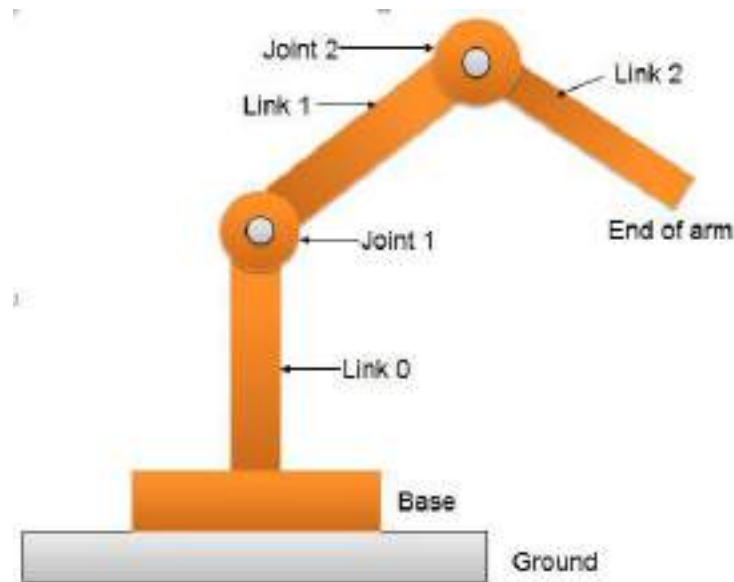


Fig. 3.5.1 Joint-link scheme for robot manipulator

Nearly all industrial robots have mechanical joints that can be classified into following five types as shown in Figure 3.5.2.

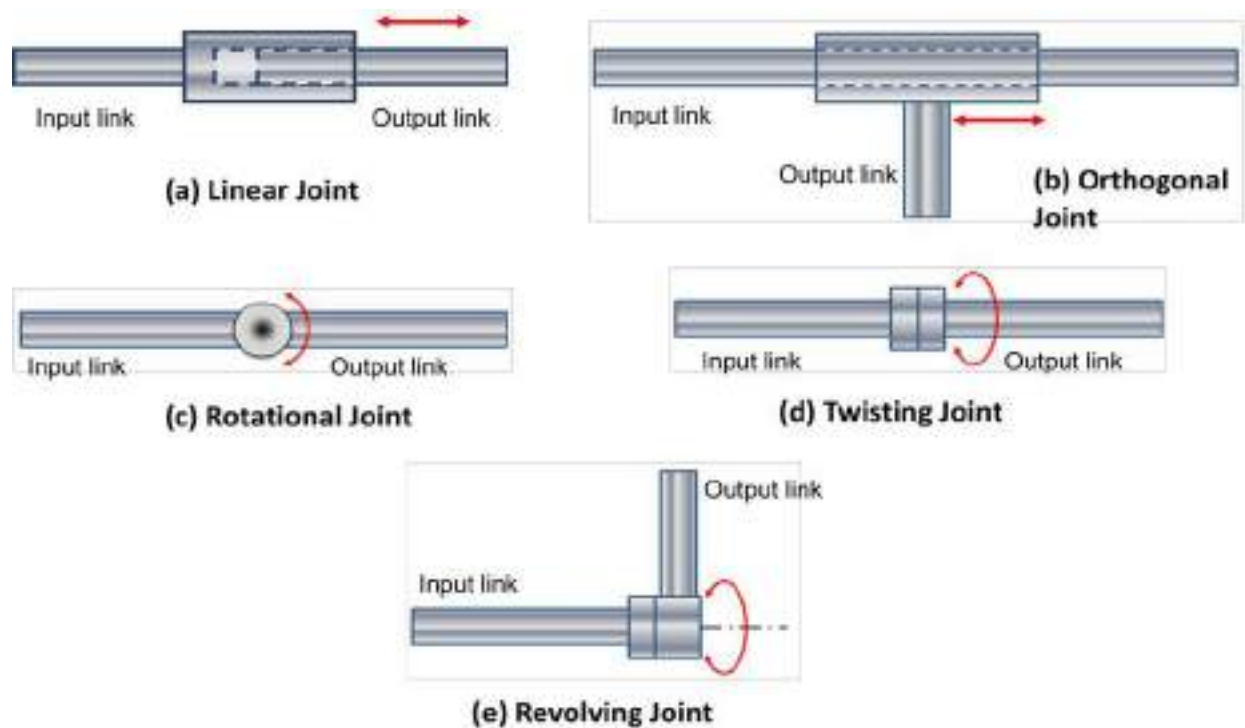


Fig. 3.5.2 Types of Joints

**1. Linear joint (type L-joint)**

The relative movement between the input link and the output link is a translational sliding motion, with the axes of the two links being parallel.

**2. Orthogonal joint (type U-joint)**

This is also a translational sliding motion, but the input and output links are perpendicular to each other during the move.

**3. Rotational joint (type R-joint)**

This type provides rotational relative motion, with the axis of rotation perpendicular to the axes of the input and output links.

**4. Twisting joint (type T-joint)**

This joint also involves rotary motion, but the axis of rotation is parallel to the axes of the two links.

**5. Revolving joint (type V-joint, V from the “v” in revolving)**

In this type, axis of input link is parallel to the axis of rotation of the joint. However the axis of the output link is perpendicular to the axis of rotation.

## 2.2 Common Robot Configurations

Basically the robot manipulator has two parts viz. a body-and-arm assembly with three degrees-of-freedom; and a wrist assembly with two or three degrees-of-freedom.

For body-and-arm configurations, different combinations of joint types are possible for a three-degree-of-freedom robot manipulator. Five common body-and-arm configurations are outlined in figure 3.5.3.

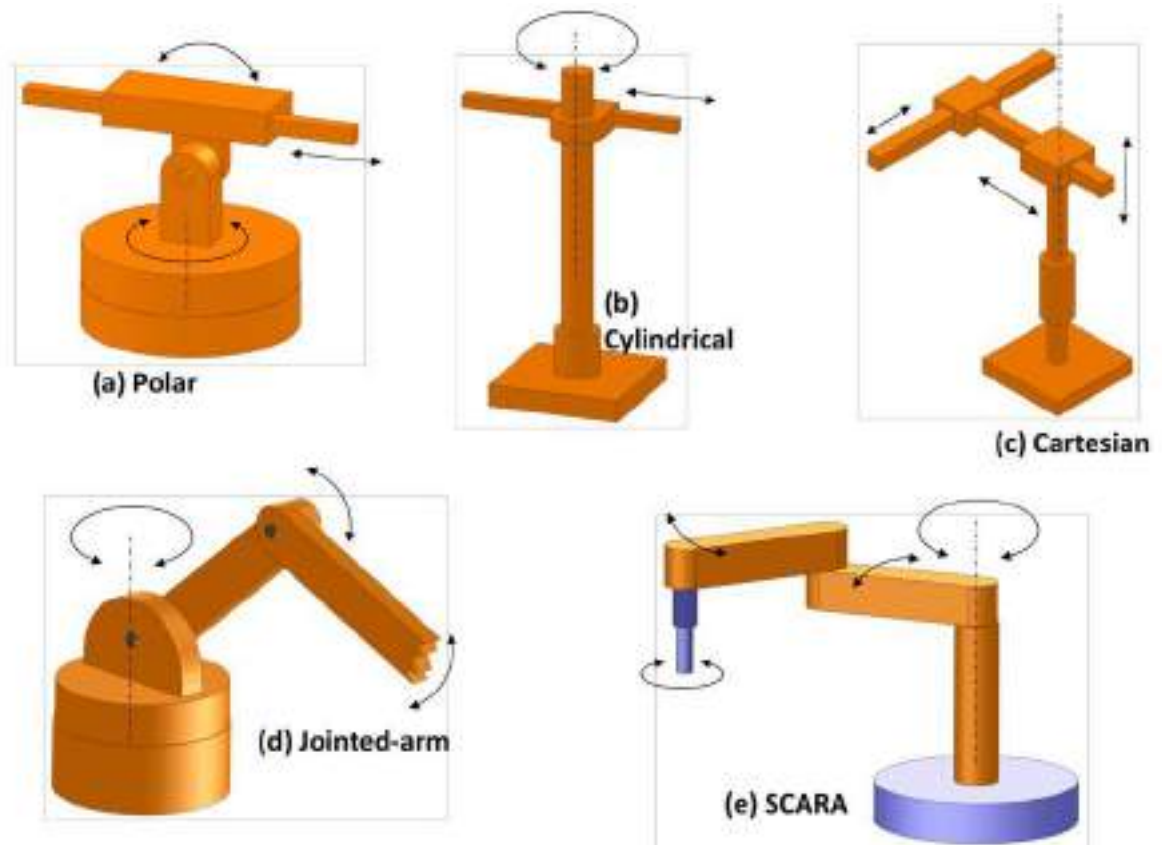


Fig.3.5.3 Common Body-and-Arm configurations

### (a) Polar configuration

It consists of a sliding arm L-joint, actuated relative to the body, which rotates around both a vertical axis (T-joint), and horizontal axis (R-joint).

- **Cylindrical configuration**

It consists of a vertical column. An arm assembly is moved up or down relative to the vertical column. The arm can be moved in and out relative to the axis of the column. Common configuration is to use a T-joint to rotate the column about its axis. An L-joint is used to move the arm assembly vertically along the column, while an O-joint is used to achieve radial movement of the arm.

- **Cartesian co-ordinate robot**

It is also known as rectilinear robot and x-y-z robot. It consists of three sliding joints, two of which are orthogonal O-joints.

### 1. Jointed-arm robot

It is similar to the configuration of a human arm. It consists of a vertical column that swivels about the base using a T-joint. Shoulder joint (R-joint) is located at the top of the column. The output link is an elbow joint (another R joint).

### 2. SCARA

Its full form is ‘Selective Compliance Assembly Robot Arm’. It is similar in construction to the jointer-arm robot, except the shoulder and elbow rotational axes are vertical. It means that the arm is very rigid in the vertical direction, but compliant in the horizontal direction.

Robot wrist assemblies consist of either two or three degrees-of-freedom. A typical three-degree-of-freedom wrist joint is depicted in Figure 3.5.4. The roll joint is accomplished by use of a T-joint. The pitch joint is achieved by recourse to an R-joint. And the yaw joint, a right-and-left motion, is gained by deploying a second R-joint.

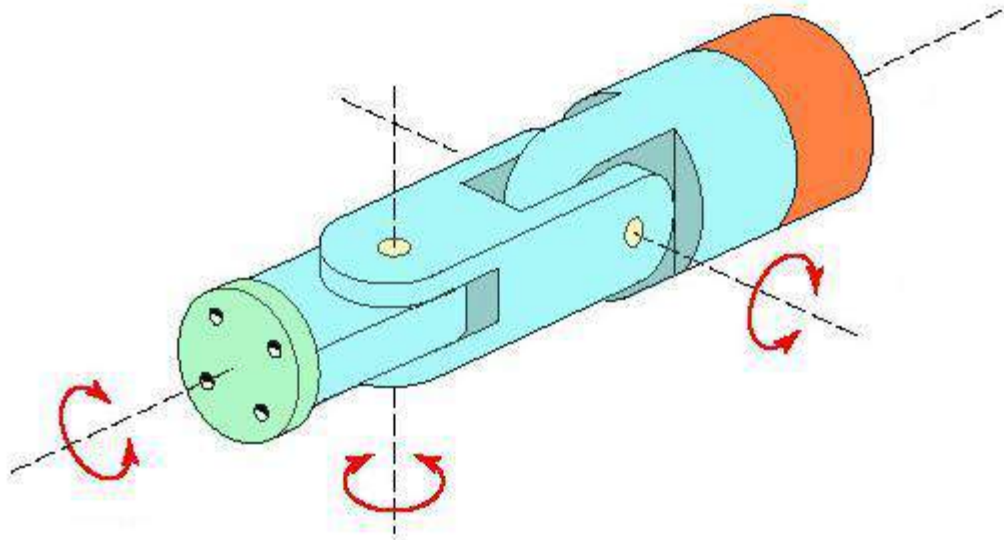


Fig. 7.5.4: Robotic wrist joint

The SCARA body-and-arm configuration typically does not use a separate wrist assembly. Its usual operative environment is for insertion-type assembly operations where wrist joints are unnecessary. The other four body-and-arm configurations more-or-less follow the wrist-joint configuration by deploying various combinations of rotary joints viz. type R and T.

### 3.10 Drive, Arm, End Effectors, Sensor

Basically three types of drive systems are commonly used to actuate robotic joints. These are electric, hydraulic, and pneumatic drives. Electric motors are the prime movers in robots. Servo-motors or stepper motors are widely used in robotics. Hydraulic and pneumatic systems such as piston-cylinder systems, rotary vane actuators are used to accomplish linear motions, and rotary motions of joints respectively.

Pneumatic drive is regularly used for smaller, simpler robotic applications; whereas electric and hydraulic drives may be found applications on more sophisticated industrial robots. Due to the advancement in electric motor technology made in recent years, electric drives are generally favored in commercial applications. They also have compatibility to computing systems. Hydraulic systems, although not as flexible as electrical drives, are generally used where larger speeds are required. They are generally employed to carry out heavy duty operations using robots.

The combination of drive system, sensors, and feedback control system determines the dynamic response characteristics of the manipulator. Speed in robotic terms refers to the absolute velocity of the manipulator at its end-of-arm. It can be programmed into the work cycle so that different portions of the cycle are carried out at different velocities. Acceleration and deceleration control are also important factors, especially in a confined work envelope. The robot's ability to control the switching between velocities is a key determinant of the manipulator's capabilities. Other key determinants are the weight (mass) of the object being manipulated, and the precision that is required to locate and position the object correctly. All of these determinants are gathered under the term 'speed of response', which is defined as the time required for the manipulator to move from one point in space to the next. Speed of response influences the robot's cycle time, which in turn affects the production rate that can be achieved.

Stability refers to the amount of overshoot and oscillation that occurs in the robot motion at the end-of- arm as it attempts to move to the next programmed location. More oscillations in the robotic motion lead to less stability in the robotic manipulator. However, greater stability may produce a robotic system with slower response times.

Load carrying capacity is also an important factor. It is determined by weight of the gripper used to grasp the objects. A heavy gripper puts a higher load upon the robotic manipulator in addition to the object mass. Commercial robots can carry loads of up to 900 kg, while medium-sized industrial robots may have capacities of up to 45kg.

## **1. Robot Control Systems**

To perform as per the program instructions, the joint movements an industrial robot must accurately be controlled. Micro-processor-based controllers are used to control the robots. Different types of control that are being used in robotics are given as follows.

### **1. Limited Sequence Control**

It is an elementary control type. It is used for simple motion cycles, such as pick-and-place operations. It is implemented by fixing limits or mechanical stops for each joint and sequencing the movement of joints to accomplish operation. Feedback loops may be used to inform the controller that the action has been performed, so that the program can move to the next step. Precision of such control system is less. It is generally used in pneumatically driven robots.

### **2. Playback with Point-to-Point Control**

Playback control uses a controller with memory to record motion sequences in a work cycle, as well as associated locations and other parameters, and then plays back the work cycle during program execution. Point-to-point control means individual robot positions are recorded in the memory. These positions include both mechanical stops for each joint, and the set of values that represent locations in the range of each joint. Feedback control is used to confirm that the individual joints achieve the specified locations in the program.

### **3. Playback with Continuous Path Control**

Continuous path control refers to a control system capable of continuous simultaneous control of two or more axes. The following advantages are noted with this type of playback control: greater storage capacity—the number of locations that can be stored is greater than in point-to-point; and interpolation calculations may be used, especially linear and circular interpolations.

### **4. Intelligent Control**

An intelligent robot exhibits behavior that makes it seems to be intelligent. For example, it may have capacity to interact with its ambient surroundings; decision-making capability; ability to communicate with humans; ability to carry out computational analysis during the work cycle; and responsiveness to advanced sensor inputs. They may also possess the playback facilities. However it requires a high level of computer control, and an advanced programming language to input the decision-making logic and other 'intelligence' into the memory.



## 2. End Effectors

An end effector is usually attached to the robot's wrist, and it allows the robot to accomplish a specific task. This means that end effectors are generally custom-engineered and fabricated for each different operation. There are two general categories of end effectors viz. grippers and tools.

Grippers grasp and manipulate the objects during the work cycle. Typically objects that grasped are the work parts which need to be loaded or unloaded from one station to another. Grippers may be custom-designed to suit the physical specifications of work parts. Various end-effectors, grippers are summarized in Table 3.6.1.

Table 3.6.1 End-Effectors: Grippers

Type	Description
Mechanical gripper	Two or more fingers which are actuated by robot controller to open and close on a workpart.
Vacuum gripper	Suction cups are used to hold flat objects.
Magnetized devices	Based on the principle of magnetism. These are used for holding ferrous workparts.
Adhesive devices	By deploying adhesive substances, these are used to hold flexible materials, such as fabric.
Simple mechanical devices	Hooks and scoops.
Dual grippers	It is a mechanical gripper with two gripping devices in one end-effector. It is used for machine loading and unloading. It reduces cycle time per part by gripping two workparts at the same time.
Interchangeable fingers	Mechanical gripper with an arrangement to have modular fingers to accommodate different sizes workpart.
Sensory feedback fingers	Mechanical gripper with sensory feedback capabilities in the fingers to aid locating the workpart; and to determine correct grip force to apply (for fragile workparts).
Multiple fingered grippers	Mechanical gripper as per the general anatomy of human hand.
Standard grippers	Mechanical grippers that are commercially available, thus reducing the need to custom-design a gripper for separate robot applications.

The robot end effector may also use tools. Tools are used to perform processing operations on the workpart. Typically the robot uses the tool relative to a stationary or slowly-moving object. For example, spot welding, arc welding, and spray painting robots use a tool for processing the respective operation. Tools also can be mounted at robotic manipulator spindle to carry out machining work such as drilling, routing, grinding, etc.

### 3. Sensors in Robotics

There are generally two categories of sensors used in robotics. These are sensors for internal purposes and for external purposes. Internal sensors are used to monitor and control the various joints of the robot. They form a feedback control loop with the robot controller. Examples of internal sensors include potentiometers and optical encoders, while tachometers of various types are deployed to control the speed of the robot arm.

External sensors are external to the robot itself, and are used when we wish to control the operations of the robot. External sensors are simple devices, such as limit switches that determine whether a part has been positioned properly, or whether a part is ready to be picked up from an unloading bay.

Various sensors used in robotics are outlined in Table 3.6.2.

Table 3.6.2 Sensor technologies for robotics

Sensor Type	Description
Tactile sensors	Used to determine whether contact is made between sensor and another object Touch sensors: indicates the contact Force sensors: indicates the magnitude of force with the object
Proximity sensors	Used to determine how close an object is to the sensor. Also called a range sensor.
Optical sensors	Photocells and other photometric devices that are used to detect the presence or absence of objects. Often used in conjunction with proximity sensors.
Machine vision	Used in robotics for inspection, parts identification, guidance, etc.
Others	Measurement of temperature, fluid pressure, fluid flow, electrical voltage, current, and other physical properties.

### 3.11 Functional requirements of robot

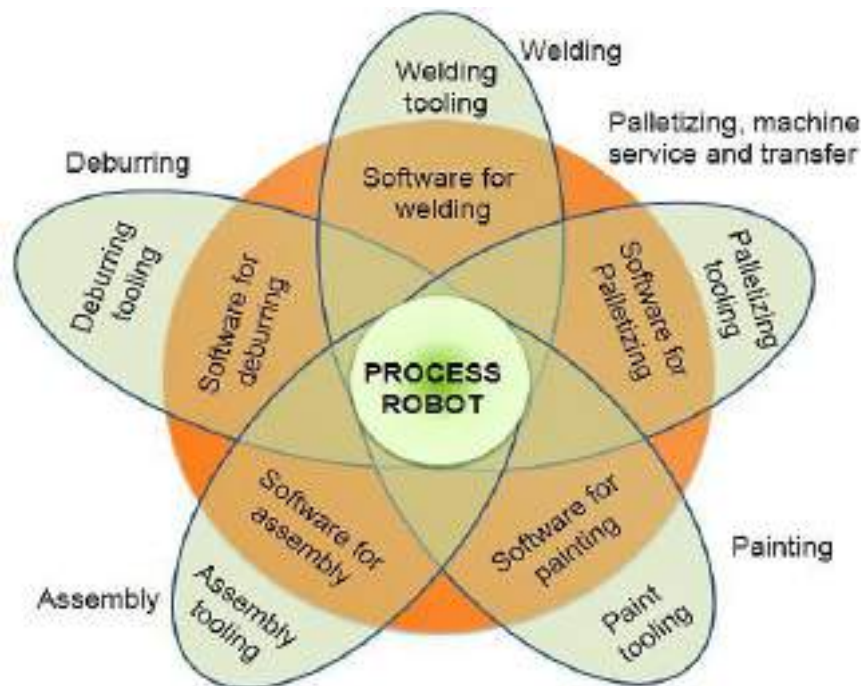


Fig. 3.6.1 Applications of robots in industry and manufacturing

Figure 3.6.1 shows a diagram which depicts an overview of applications of robots in manufacturing. The general characteristics of industrial work situations that tend to promote the substitution of robots for human labor are outlined in Table 3.6.3.

Table 3.6.3: Characteristics of situations where robots may substitute for humans

Situation	Description
Hazardous work environment for humans	In situations where the work environment is unsafe, unhealthy, uncomfortable, or otherwise unpleasant for humans, robot application may be considered.
Repetitive work cycle	If the sequence of elements in the work cycle is the same, and the elements consist of relatively simple motions, robots usually perform the work with greater consistency and repeatability than humans.
Difficult handling for humans	If the task requires the use of heavy or difficult-to-handle parts or tools for humans, robots may be able to perform the operation more efficiently.
Multi-shift operation	A robot can replace two or three workers at a time in second or third shifts, thus they can provide a faster financial payback.
Infrequent changeovers	Robots' use is justified for long production runs where there are infrequent changeovers, as opposed to batch or job shop production where changeovers are more frequent.
Part position and orientation are established in the work cell	Robots generally don't have vision capabilities, which means parts must be precisely placed and oriented for successful robotic operations.



## Material Handling Applications

Robots are mainly used in three types of applications: material handling; processing operations; and assembly and inspection. In material handling, robots move parts between various locations by means of a gripper type end effector. Material handling activity can be sub divided into material transfer and machine loading and/or unloading. These are described in Table 3.6.4.

Table 3.6.4: Material handling applications

Application	Description
Material transfer	<ul style="list-style-type: none"> <li>• Main purpose is to pick up parts at one location and place them at a new location. Part re-orientation may be accomplished during the transfer. The most basic application is a pick-and-place procedure, by a low-technology robot (often pneumatic), using only up to 4 joints.</li> <li>• More complex is palletizing, where robots retrieve objects from one location, and deposit them on a pallet in a specific area of the pallet, thus the deposit location is slightly different for each object transferred. The robot must be able to compute the correct deposit location via powered lead-through method, or by dimensional analysis.</li> <li>• Other applications of material transfer include de-palletizing, stacking, and insertion operations.</li> </ul>
Machine loading and/or unloading	<ul style="list-style-type: none"> <li>• Primary aim is to transfer parts into or out-of a production machine.</li> <li>• There are three classes to consider:               <ul style="list-style-type: none"> <li>○ machine loading—where the robot loads the machine</li> <li>○ machine unloading—where the robot unloads the machine</li> <li>○ machine loading and unloading—where the robot performs both actions</li> </ul> </li> <li>• Used in die casting, plastic molding, metal machining operations, forging, press-working, and heat treating operations.</li> </ul>

## Processing Operations

In processing operations, the robot performs some processing activities such as grinding, milling, etc. on the workpart. The end effector is equipped with the specialized tool required for the respective process. The tool is moved relative to the surface of the workpart. Table 7.6.5 outlines the examples of various processing operations that deploy robots.

**Table 7.6.5: Robotic process operations**

<b>Process</b>	<b>Description</b>
Spot Welding	Metal joining process in which two sheet metal parts are fused together at localized points of contact by the deployment of two electrodes that squeeze the metal together and apply an electric current. The electrodes constitute the spot welding gun, which is the end effector tool of the welding robot.
Arc Welding	Metal joining process that utilizes a continuous rather than contact welding point process, in the same way as above. Again the end effector is the electrodes used to achieve the welding arc. The robot must use continuous path control, and a jointed arm robot consisting of six joints is frequently used.
Spray Coating	Spray coating directs a spray gun at the object to be coated. Paint or some other fluid flows through the nozzle of the spray gun, which is the end effector, and is dispersed and applied over the surface of the object. Again the robot must use continuous path control, and is typically programmed using manual lead-through. Jointed arm robots seem to be the most common anatomy for this application.
Other applications	Other applications include: drilling, routing, and other machining processes; grinding, wire brushing, and similar operations; waterjet cutting; and laser cutting.

## **COURSE OUTCOME**

Students will

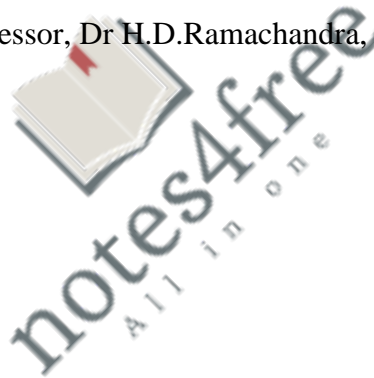
1. Understand the concept and working of PLC's
2. Learn the various types of actuator.
3. Know the concept and working of Industrial robots.

## **SELF ASSESSMENT QUESTIONS**

1. With a neat block diagram explain PLC architecture.
2. What does Central Processing Unit (CPU) of PLC consists
3. Draw the flow diagram of ladder.
4. Explain the concept of actuators.
5. Explain the main features and functions of Industrial robots.

## **FURTHER READING**

1. Mechatronics and microprocessor, Dr H.D.Ramachandra, Sudha Publications, Bangalore, 2018



# **Module 4:**

## **Mechanical actuation systems and Electrical actuation systems**

### CONTENTS

#### **Mechanical actuation systems**

- 4.1 Mechanical systems
- 4.2 types of motion
- 4.3 Cams, Gear trains, Ratchet & Pawl, belt and chain drives
- 4.4 Mechanical aspects of motor selection

#### **Electrical actuation systems**

- 4.5 Electrical systems
- 4.6 Mechanical switches
- 4.7 Solenoids, Relays
- 4.8 DC/AC Motors
- 4.9 Principle of Stepper Motors & servomotors

### **OBJECTIVE**

- Is to understand concepts and working of Mechanical actuation systems.
- Is to understand concepts and working of Electrical actuation systems



## 4.1 Mechanical systems

**Mechanical Systems** Devices which can be considered to be motion converters in that they transform motion from one form to some other required form. –Eg: Transform linear motion into rotational motion and vice versa; A linear reciprocating motion into rotary motion. Mechanical elements can include the use of linkages, cams, gears, rack-and-pinion, chains, belt drives, etc. – Eg: rack-and-pinion can be used to convert rotational motion to linear motion. Many of the actions which previously were obtained by the use of mechanism are, however, often nowadays being obtained, as a result of a mechatronics approach by the use of microprocessor systems.

## 4.2 Types of Motion

The motion of an object shows its changing position, as discussed earlier. But varying objects show varying types of motion. Like for example, a fan is said to be in motion though it is static in its place or a hanging clock that shows motion though it is hanging in its position. We say that motion is mainly of three types: Rectilinear Motion, Circular Motion and Periodic Motion.

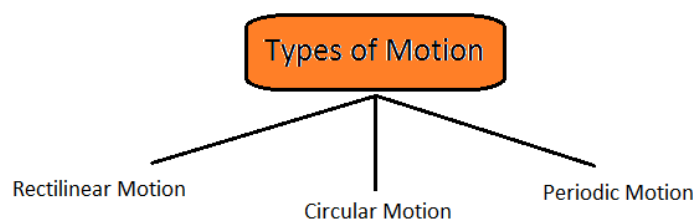


Fig 4.1: Types of motion

### Rectilinear Motion

In a rectilinear motion, all the objects move along a single line. Some common examples of rectilinear motion are marching soldiers, moving cars, and moving animals. The common thing in all these examples is that they move in a single line

### Circular Motion

Some objects are moving even though they are fixed at some position. here the fan undergoes circular motion. In the [circular motion](#), the objects follow a circular path of motion without changing their position. It is the circular movement of fan that results in cool air. Some more examples of circular motion are the motion of a Ferry wheel, satellites and rotation of planets around the sun.

### Periodic Motion

Physically the pendulum isn't moving. It is fixed to some point, yet it shows motion. This kind of motion that repeats after a specific period of time is known as periodic motion. In the [periodic motion](#), the movement made by these objects is called oscillation.

Since it repeats after a fixed period of time, it is named so! Clocks and table fans are the most common examples. Some other examples of the periodic motion are a child's motion on swings, the motion of the earth around the Sun, the motion of the moon around the earth

### 4.3 Cams, Gear trains, Ratchet & Pawl, belt and chain drives

#### Cams

Cams are mechanical devices which are used to generate curvilinear or irregular motion of mechanical elements. They are used to convert rotary motion into oscillatory motion or oscillatory motion into rotary motion. There are two links namely the cam itself which acts as an input member. The other link that acts as an output member is called the follower. The cam transmits the motion to the follower by direct contact. In a cam-follower pair, the cam usually rotates while the follower translates or oscillates. Complicated output motions which are otherwise difficult to achieve can easily be produced with the help of cams. Cams are widely used in internal combustion engines, machine tools, printing control mechanisms, textile weaving industries, automated machines etc.

Necessary elements of a cam mechanism are shown in Figure 4.3.1.

- A driver member known as the cam
- A driven member called the follower
- A frame which supports the cam and guides the follower

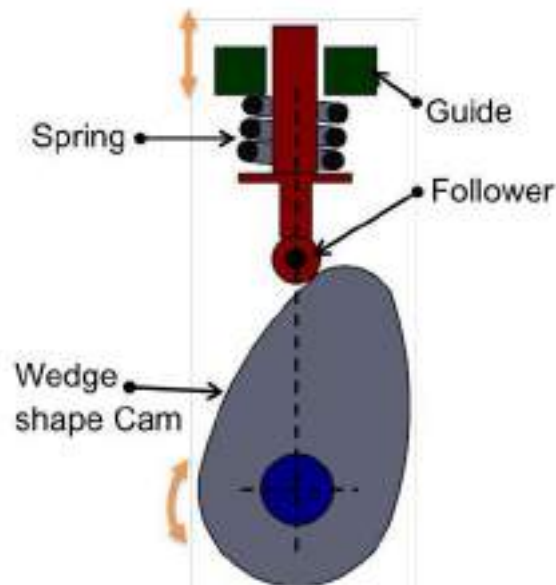


Figure 4.3.1 Cam mechanism.

## 1. Classification of cams

### 1.1 Wedge and Flat Cams

A wedge cam has a wedge of specified contour and has translational motion. The follower can either translate or oscillate. A spring is used to maintain the contact between the cam and the follower. Figure 4.3.2 shows the typical arrangement of Wedge cam.

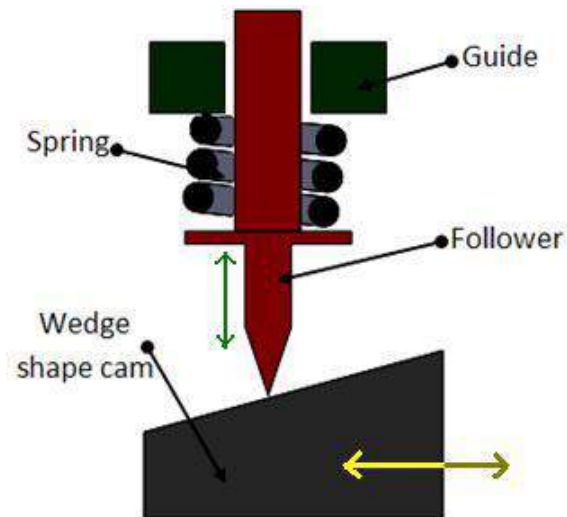


Figure 4.3.2 Wedge cam

## 1.2 Plate cam

In this type of cams, the follower moves in a radial direction from the centre of rotation of the cam (Figure 4.3.3). They are also known as radial or disc cam. The follower reciprocates or oscillates in a plane normal to the cam axis. Plate cams are very popular due to their simplicity and compactness.

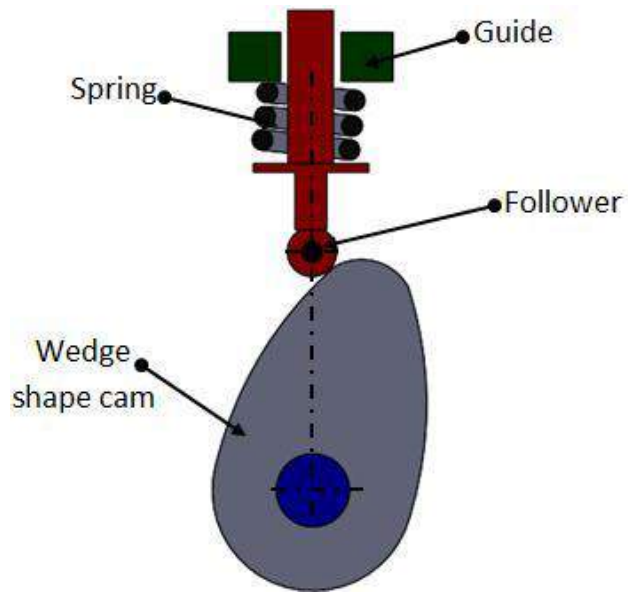


Figure 4.3.3 Plate cam

## 1.3 Cylindrical cam

Here a cylinder has a circumferential contour cut in the surface and the cam rotates about its axis (Figure 4.3.4). The follower motion is either oscillating or reciprocating type. These cams are also called drum or barrel cams.

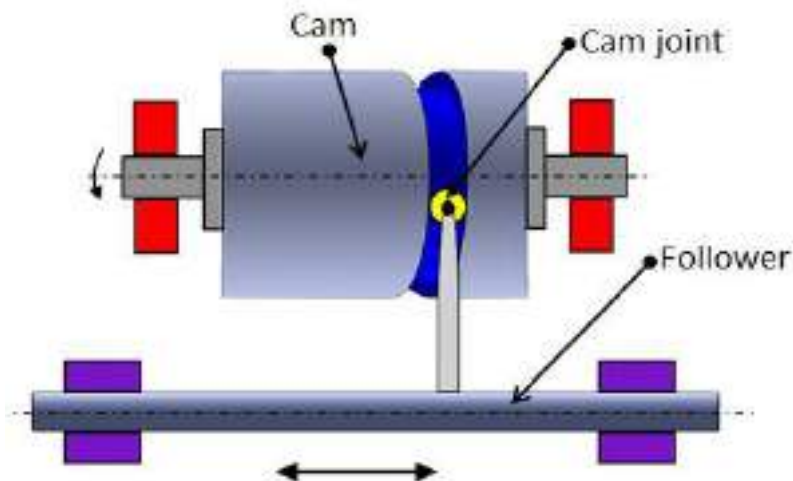


Figure 4.3.4 Cylindrical cam

## 2. Classification of followers:

Followers can be classified based on

- type of surface contact between cam and follower
- type of follower motion
- line of motion of followers

### 2.1 Classification based on type of surface contact between cam and follower

Figure 4.3.5 shows the schematics of various types of followers used cam mechanisms.

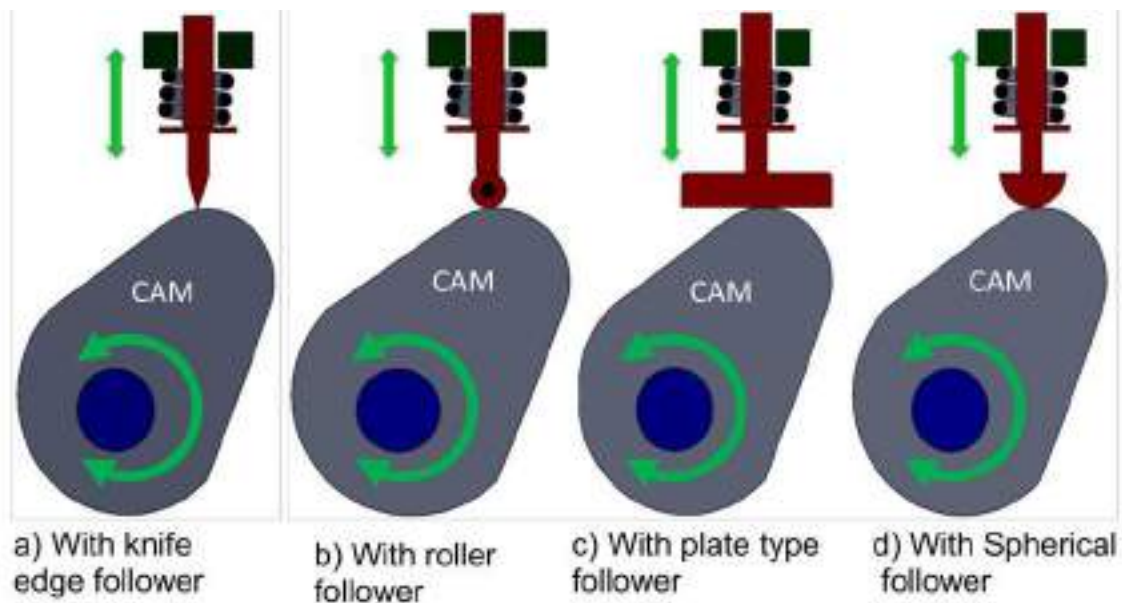


Figure 4.3.5 Types of follower based on the surface in contact

#### 2.1.1 Knife edge follower

The contacting end of the follower has a sharp knife edge. A sliding motion exists between the contacting cam and follower surfaces. It is rarely used in practice because the small area of contacting surface results in excessive wear.

#### 2.1.2 Roller follower

It consists of a cylindrical roller which rolls on cam surface. Because of the rolling motion between the contacting surfaces, the rate of wear is reduced in comparison with Knife edge follower. The roller followers are extensively used where more space is available such as gas and oil engines.

### 2.1.3 Flat face follower

The follower face is perfectly flat. It experiences a side thrust due to the friction between contact surfaces of follower and cam.

### 2.1.4 Spherical face follower

The contacting end of the follower is of spherical shape which overcomes the drawback of side thrust as experienced by flat face follower.

## 2.2 Classification based on followers' motion

Figure 4.3.6 shows the types of cams based followers' motion.

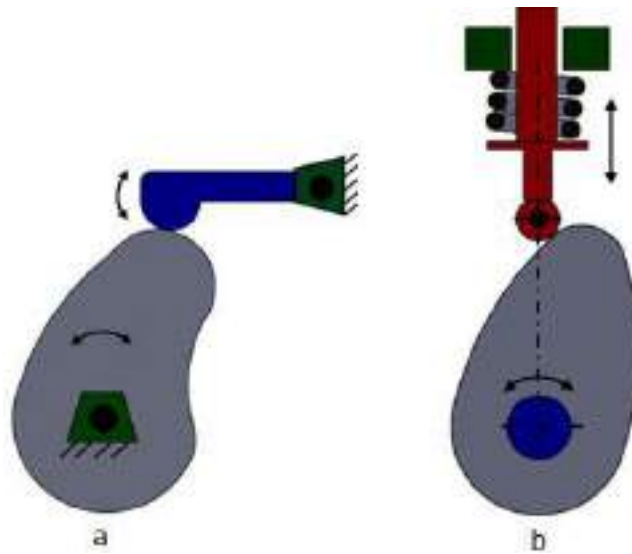


Figure 4.3.6 Classification of follower based on motion

### 2.2.1 Oscillating follower

In this configuration, the rotary motion of the cam is converted into predetermined oscillatory motion of the follower as shown in Figure 4.3.6 a).

### 2.2.2 Translating follower

These are also called as reciprocating follower. The follower reciprocates in the 'guide' as the cam rotates uniformly as shown in Figure 4.3.6 b).

## Classification based on line of motion

Figure 4.3.7 shows the types of cams based followers' line of motion.

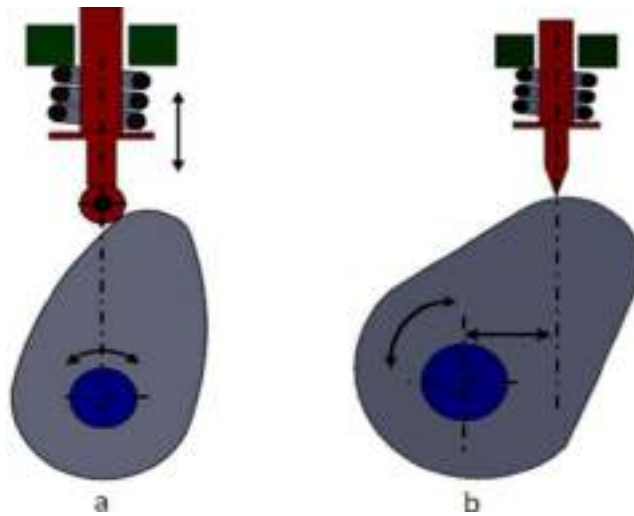


Figure 4.3.7 Classification of follower based on line of motion

### 4.3.1 Radial follower

The line of movement of the follower passes through the center of the camshaft (Figure 4.3.7 a).

### 4.3.2 Offset follower

The line of movement of the follower is offset from the center of the cam shaft (Figure 4.3.7 b).

### 3. Force closed cam follower system

In this type of cam-follower system, an external force is needed to maintain the contact between cam and follower. Generally a spring maintains the contact between the two elements. The follower can be a oscillating type (Figure 4.3.8 a) or of translational type (Figure 4.3.8 b).

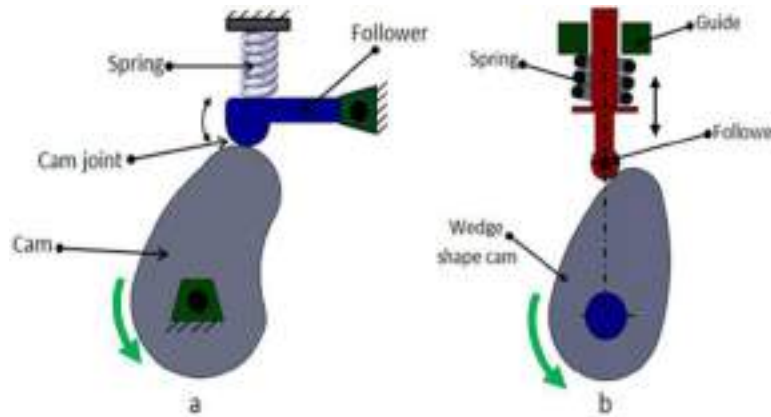


Figure 4.3.8 Force closed cam followers

### 4. Form closed cam follower system

In this system a slot or a groove profile is cut in the cam. The roller fits in the slot and follows the groove profile. These kind of systems do not require a spring. These are extensively used in machine tools and machinery. The follower can be a translating type (Figure 4.3.9 a) oscillating type (Figure 4.3.9 b).

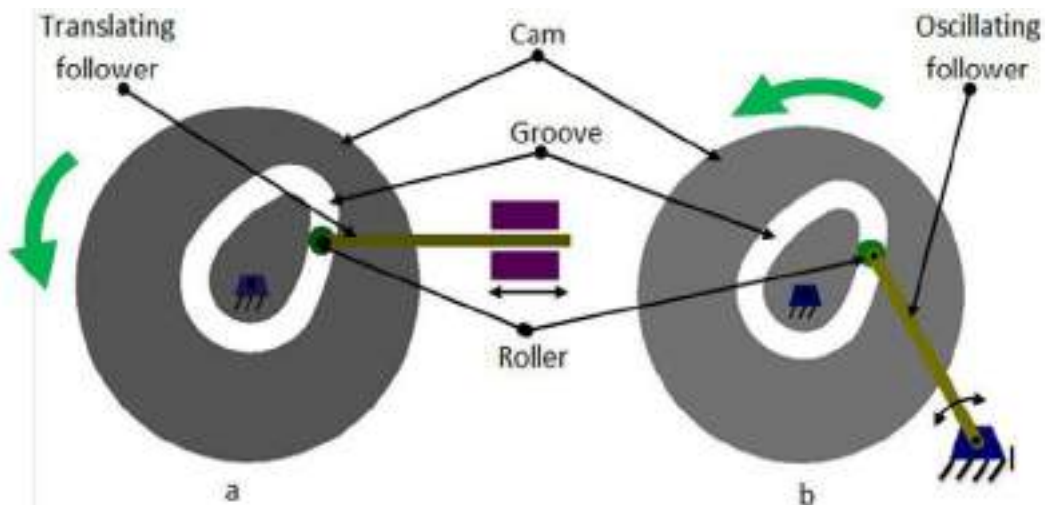


Figure 4.3.9 Form closed cam followers



### ***5. Three-dimensional cam or Camoid***

Camoid is a combination of radial and axial cams. It has three dimensional surface and two degrees-of-freedom. Two inputs are rotation of the cam about its axis and translation of the cam along its axis. Follower motion is based on both the inputs. Figure 4.3.10 shows a typical Camoid.



**Figure 4.3.10 A Camoid**

## 6. Applications of cams

Cams are widely used in automation of machinery, gear cutting machines, screw machines, printing press, textile industries, automobile engine valves, tool changers of machine centers, conveyors, pallet changers, sliding fork in wearhouses etc.

Cams are also used in I.C engines to operate the inlet valves and exhaust valves. The cam shaft rotates by using prime moveres. It causes the rotation of cam. This rotation produces translatory motion of tappet against the spring. This translatory motion is used to open or close the valve. The schematic of this operation is shown in Figure 4.3.11.

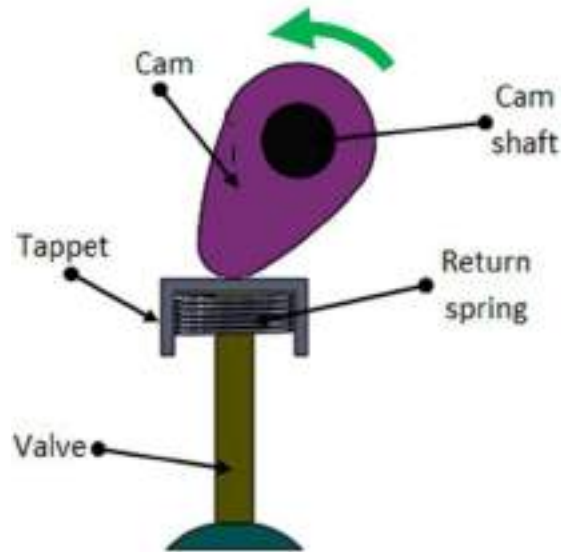


Figure 4.3.11 Cam in I.C engine

### 6.1 Cams in automatic lathes

The cam shaft is driven by a motor. The cutting tool mounted on the transverse slide travels to desired depth and at desired feed rate by a set of plate cams mounted on the cam shaft. The bar feeding through headstock at desired feed rate is carried out by a set of plate cams mounted on the camshaft.

## 6.2 Automatic copying machine

The cam profile can be transferred onto the work piece by using a roller follower as shown in Figure 4.3.12. The follower can be mounted with a cutting tool. As the cam traverses, the roller follows the cam profile. The required feature can be copied onto the workpiece by the movement of follower over the cam profile.

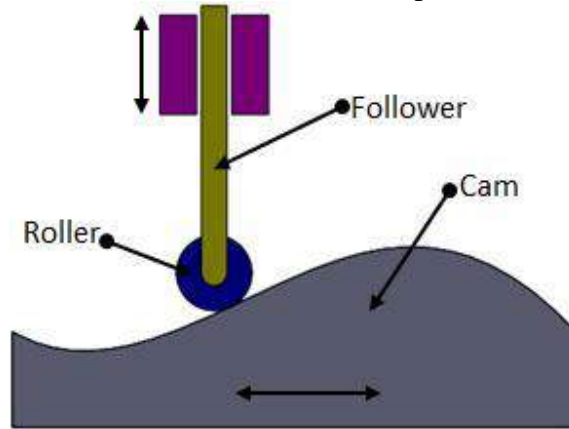


Figure 4.3.12 Automatic copying of cam profile

## Ratchet and pawl mechanism

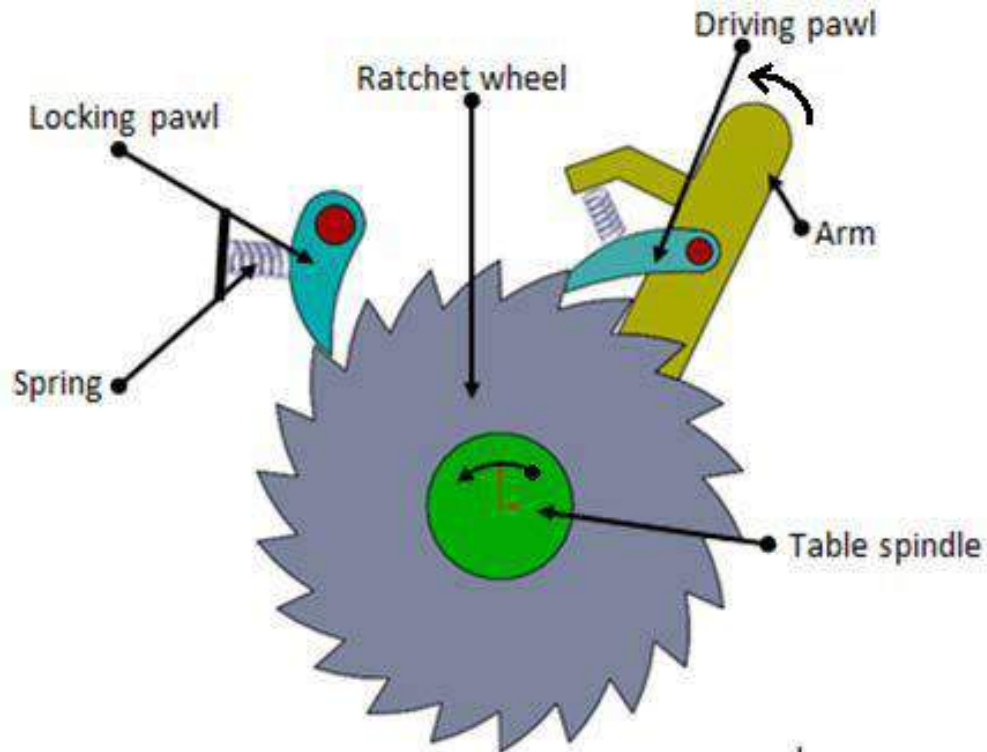


Fig. 4.5.1 Ratchet and pawl mechanism

A ratchet is a device that allows linear or rotary motion in only one direction. Figure 4.5.1 shows a schematic of the same. It is used in rotary machines to index air operated indexing tables. Ratchets consist of a gearwheel and a pivoting spring loaded pawl that engages the teeth. The teeth or the pawl, are at an angle so that when the teeth are moving in one direction the pawl slides in between the teeth. The spring forces the pawl back into the depression between the next teeth. The ratchet and pawl are not mechanically interlocked hence easy to set up. The table may over travel if the table is heavy when they are disengaged. Maintenance of this system is easy.

## Rack and pinion mechanism

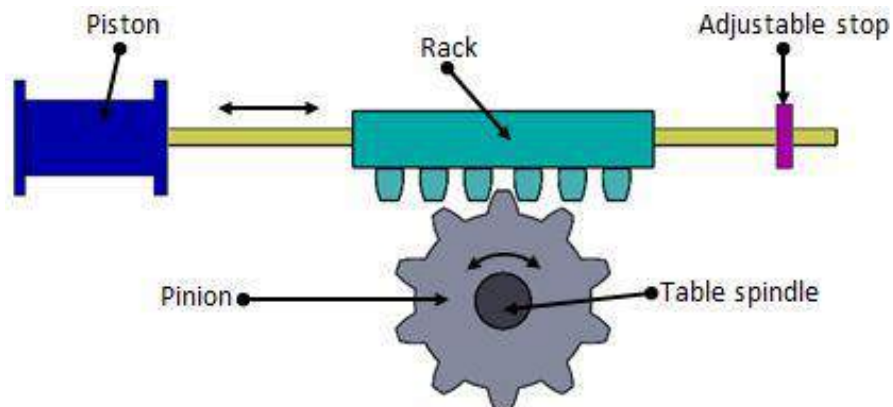


Fig. 4.5.2 Rack and pinion mechanism

A rack and pinion gear arrangement usually converts rotary motion from a pinion to linear motion of a rack. But in indexing mechanism the reverse case holds true. The device uses a piston to drive the rack, which causes the pinion gear and attached indexing

table to rotate (Fig. 4.5.2). A clutch is used to provide rotation in the desired direction. This mechanism is simple but is not considered suitable for high-speed operation.

## Geneva mechanism

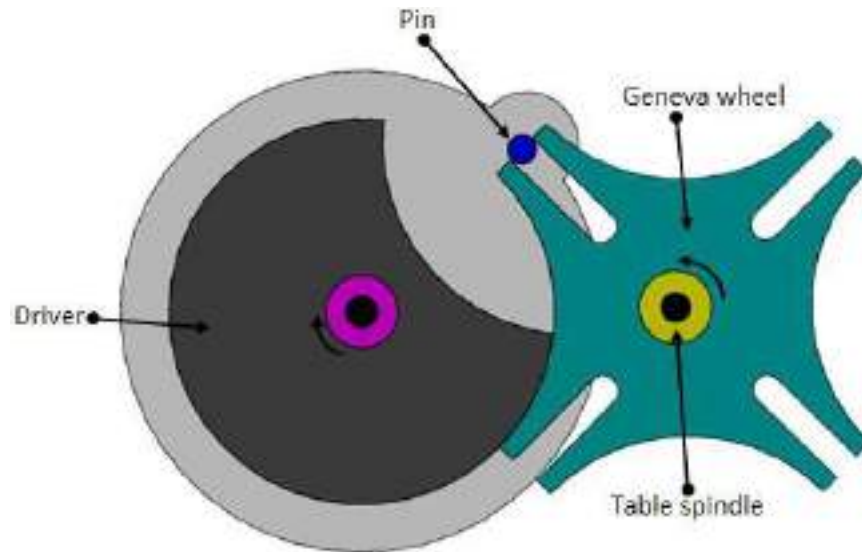


Fig. 4.5.3 Geneva mechanism

The Geneva drive is also commonly called a Maltese cross mechanism. The Geneva mechanism translates a continuous rotation into an intermittent rotary motion. The rotating drive wheel has a pin that reaches into a slot of the driven wheel. The drive wheel also has a raised circular blocking disc that locks the driven wheel in position between steps (Fig. 4.5.3). There are three basic types of Geneva motion mechanisms namely external, internal and spherical. The spherical Geneva mechanism is very rarely used. In the simplest form, the driven wheel has four slots and hence for each rotation of the drive wheel it advances by one step of  $90^\circ$ . If the driven wheel has  $n$  slots, it advances by  $360^\circ/n$  per full rotation of the drive wheel.

In an internal Geneva drive the axis of the drive wheel of the internal drive is supported on only one side (Fig. 4.5.4). The angle by which the drive wheel has to rotate to effect one step rotation of the driven wheel is always smaller than  $180^\circ$  in an external Geneva drive and is always greater than  $180^\circ$  in an internal one. The external form is the more common, as it can be built smaller and can withstand higher mechanical stresses.

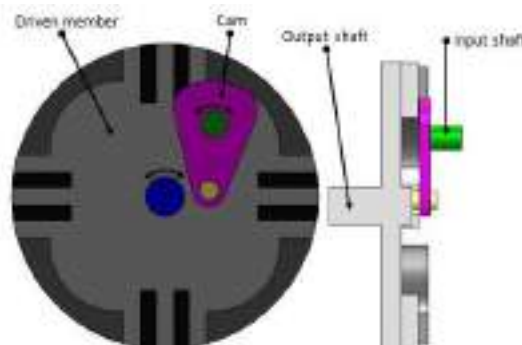


Fig. 4.5.4 Internal Geneva mechanism

Because the driven wheel always under full control of the driver, impact is a problem. It can be reduced by designing the pin in such a way that the pin picks up the driven member as slowly as possible. Both the Geneva mechanisms can be used for light and heavy duty applications. Generally, they are used in assembly machines.

Intermittent linear motion from rotary motion can also be obtained using Geneva mechanism (Fig. 4.5.5). This type of movement is basically required in packaging, assembly operations, stamping, embossing operations in manufacturing automation.

## Cams mechanism

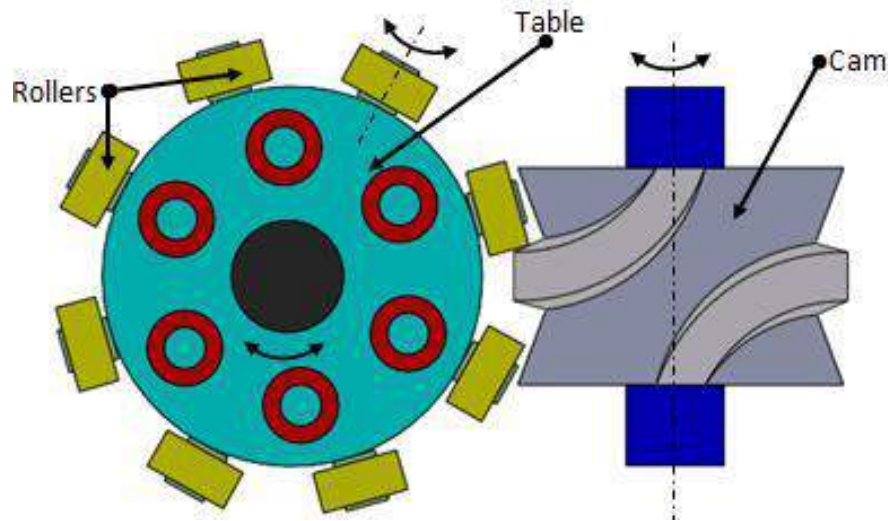


Fig. 4.5.6 Cam mechanism

Cam mechanism is one of the accurate and reliable methods of indexing. It is widely used in industry despite the fact that the cost is relatively high compared to alternative mechanisms. The cam can be designed to give a variety of velocity and dwell characteristics. The follower of the cams used in indexing mechanism has a unidirectional rotary motion rather than oscillating rotary motion which is usually the case of axial cams. The cam surface geometry is more complicated in a cross over indexing type of cam as shown in Figure 4.5.6.

## Electrical actuation systems

### 4.5 Electrical systems

#### 1. Drives

Basic function of a CNC machine is to provide automatic and precise motion control to its elements such work table, tool spindle etc. Drives are used to provide such kinds of controlled motion to the elements of a CNC machine tool. A drive system consists of drive motors and ball lead-screws. The control unit sends the amplified control signals to actuate drive motors which in turn rotate the ball lead-screws to position the machine table or cause rotation of the spindle.

## 2. Power drives

Drives used in an automated system or in CNC system are of different types such as electrical, hydraulic or pneumatic.

- **Electrical drives**

These are direct current (DC) or alternating current (AC) servo motors. They are small in size and are easy to control.

- **Hydraulic drives**

These drives have large power to size ratio and provide stepless motion with great accuracy. But these are difficult to maintain and are bulky. Generally they employ petroleum based hydraulic oil which may have fire hazards at upper level of working temperatures. Also hydraulic elements need special treatment to protect them against corrosion.

- **Pneumatic drives**

This drives use air as working medium which is available in abundant and is fire proof. They are simple in construction and are cheaper. However these drives generate low power, have less positioning accuracy and are noisy.

In CNC, usually AC, DC, servo and stepper electrical drives are used. The various drives used in CNC machines can be classified as:

- a. Spindle drives to provide the main spindle power for cutting action
- b. Feed drives to drive the axis

## 4.6 Mechanical switches

Mechanical switches can be classified into different types based on several factors such as method of actuation (manual, limit and process switches), number of contacts (single contact and multi contact switches), number of poles and throws (SPST, DPDT, SPDT, etc.), operation and construction (push button, toggle, rotary, joystick, etc), based on state (momentary and locked switches), etc.

Mechanical switches can be divided into two basic types. The first, commercial and appliance switches, are used in fairly clean environments such as offices or homes. They are not sealed and are generally used for light, low-current applications.

The second type, industrial switches, actuate magnetic contactors and remote-operated controllers. These switches must be ruggedly constructed because they are frequently exposed to oil, solvents, chemicals, and dust. And their contacts must handle the high inrush current drawn by electromagnets in the controllers. Industrial switches are available in five basic types: standard duty, heavy duty, heavy-duty oiltight, miniature oiltight, and multilight-control oiltight. The terms *standard duty* and *heavy duty* are derived from the Standards for Industrial Control Equipment of Underwriters' Laboratories Inc. for normal current and inrush current.

Manual switches can have one or a combination of switching actions. In momentary-action switches, the operator pushes (pushbutton or toggle) or twists (rotary) the actuating device and contacts move to transfer the circuits to the second set of contacts. When the actuating force is removed, the actuating device and the contacts return to the original position. When a maintained-action switch is actuated, the contacts move to transfer the circuits to the second set of contacts. No change takes place until the operator actuates the switch a second time. Then the circuit moves to another set of contacts or returns to the original position.

Mechanical-bail switches have separate switching assemblies, which are interlocked so that actuation of one switch deactivates another.

A capacitive touch switch consists of two conductive layers on opposite sides of an insulating material such as glass or a printed-circuit board. The conductive layers create a capacitance that decreases when a layer is touched. Interface circuitry converts the capacitance change into a usable switching action to drive logic systems or to switch analog signals. There are several types of touch-switch interface circuits available.

Membrane switches are simple devices in which conductive leads on the underside of a flexible membrane are, at a keystroke, pushed through a hole in a spacer to make contact with conductive leads on a base. Most membrane switches handle loads up to about 1.5 VA at 5 to 15 V

#### 4.7 Solenoids and Relays

A solenoid is a coil of insulated or enameled wire wound on a rod-shaped form made of solid iron, solid steel, or powdered iron. Devices of this kind can be used as electromagnets, as inductors in electronic circuits, and as miniature wireless receiving antennas.

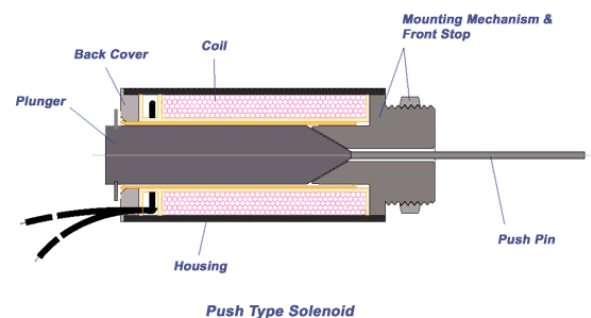


Fig 4.7.1: Solenoid



In a solenoid, the core material is ferromagnetic, meaning that it concentrates magnetic lines of flux. This increases the inductance of the coil far beyond the inductance obtainable with an air-core coil of the same dimensions and the same number of turns. When current flows in the coil, most of the resulting magnetic flux exists within the core material. Some flux appears outside the coil near the ends of the core; a small amount of flux also appears outside the coil and off to the side.

A *solenoid chime* is wound on a cylindrical, hollow, plastic or phenolic form with a movable, solid iron or steel core. The core can travel in and out of the coil along its axis. The coil is oriented vertically; the core normally rests somewhat below the coil center. When a current pulse is applied to the coil, the magnetic field pulls the core forcefully upward. Inertia carries the core above the center of the coil, where the core strikes a piece of metal similar to a xylophone bell

## Electromechanical Relay

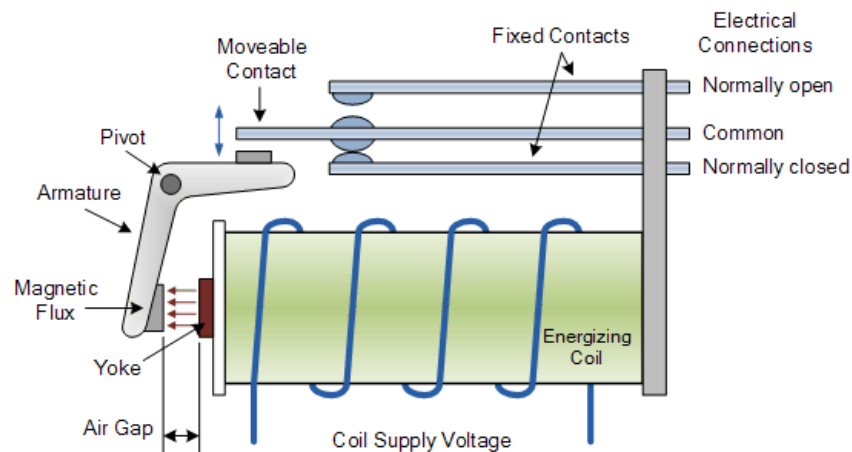


Fig 4.7.2: Relay

We have two sets of electrically conductive contacts. Relays may be “Normally Open”, or “Normally Closed”. One pair of contacts are classed as **Normally Open, (NO)** or make contacts and another set which are classed as **Normally Closed, (NC)** or break contacts. In the normally open position, the contacts are closed only when the field current is “ON” and the switch contacts are pulled towards the inductive coil.

In the normally closed position, the contacts are permanently closed when the field current is “OFF” as the switch contacts return to their normal position. These terms *Normally Open*, *Normally Closed* or *Make and Break Contacts* refer to the state of the electrical contacts when the relay coil is “de-energized”, i.e, no supply voltage connected to the relay coil. Contact elements may be of single or double make or break designs. An example of this arrangement is given below.

The relays contacts are electrically conductive pieces of metal which touch together completing a circuit and allow the circuit current to flow, just like a switch. When the contacts are open the resistance between the contacts is very high in the Mega-Ohms, producing an open circuit condition and no circuit current flows.

When the contacts are closed the contact resistance should be zero, a short circuit, but this is not always the case. All relay contacts have a certain amount of “contact resistance” when they are closed and this is called the “On-Resistance”, similar to FET’s.

With a new relay and contacts this ON-resistance will be very small, generally less than  $0.2\Omega$  because the tips are new and clean, but over time the tip resistance will increase

### 3.8 DC/AC Motors

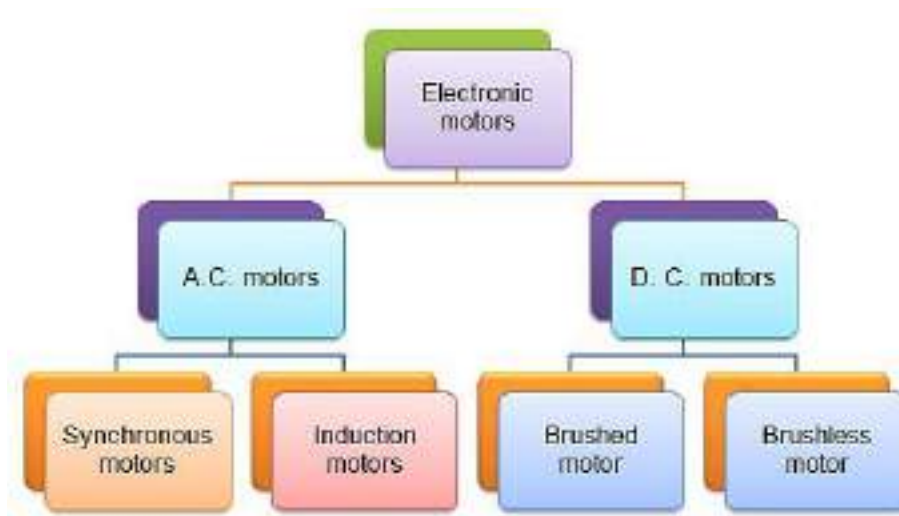


Fig. 4.1.3 Classification of motors

Electric drives are mostly used in position and speed control systems. The motors can be classified into two groups namely DC motors and AC motors (Fig. 4.1.3). In this session we shall study the operation, construction, advantages and limitations of DC and AC motors.

#### DC motors

A DC motor is a device that converts direct current (electrical energy) into rotation of an element (mechanical energy). These motors can further be classified into brushed DC motor and brushless DC motors.

##### Brush type DC motor

A typical brushed motor consists of an armature coil, slip rings divided into two parts, a pair of brushes and horse shoes electromagnet as shown in Fig. 4.1.4. A simple DC motor has two field poles namely a north pole and a south pole. The magnetic lines of force extend across the opening between the poles from north to south. The coil is wound around a soft iron core and is placed in between the magnet poles. These electromagnets receive electricity from an outside power source. The coil ends are connected to split rings. The carbon brushes are in contact with the split rings. The brushes are connected to a DC source. Here the split rings rotate with the coil while the brushes remain stationary.

**Fig. 4.1.4 Brushed DC motor**

The working is based on the principle that when a current-carrying conductor is placed in a magnetic field, it experiences a mechanical force whose direction is given by Fleming's left-hand rule. The magnitude of the force is given by

$$F = BIL \sin \theta \quad (4.1.1)$$

Where,  $B$  is magnetic field density in weber/m<sup>2</sup>

$I$  is the current in amperes and

$L$  is the length of the conductor in meter

$\theta$  is the angle between the direction of the current in the conductor and the electric field

If the current and field are perpendicular then  $\theta=90^\circ$ . The equation 4.1.1 becomes,

$$F = BIL \quad (4.1.2)$$

A direct current in a set of windings creates a magnetic field. This field produces a force which turns the armature. This force is called torque. This torque will cause the armature to turn until its magnetic field is aligned with the external field. Once aligned the direction of the current in the windings on the armature reverses, thereby reversing the polarity of the rotor's electromagnetic field. A torque is once again exerted on the rotor, and it continues spinning. The change in direction of current is facilitated by the split ring commutator. The main purpose of the commutator is to overturn the direction of the electric current in the armature. The commutator also aids in the transmission of current between the armature and the power source. The brushes remain stationary, but they are in contact with the armature at the commutator, which rotates with the armature such that at every 180° of rotation, the current in the armature is reversed.

***Advantages of brushed DC motor:***

- The design of the brushed DC motor is quite simple
- Controlling the speed of a Brush DC Motor is easy
- Very cost effective

***Disadvantages of brushed DC motor:***

- High maintenance
- Performance decreases with dust particles
- Less reliable in control at lower speeds
- The brushes wear off with usage

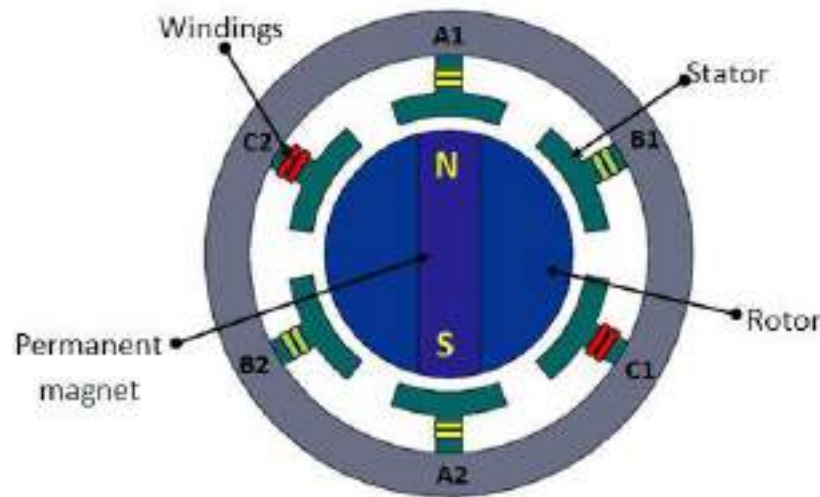
**Brushless DC motor**

Fig. 4.1.5 Brushless DC motor

A brushless DC motor has a rotor with permanent magnets and a stator with windings. The rotor can be of ceramic permanent magnet type. The brushes and commutator are eliminated and the windings are connected to the control electronics. The control electronics replace the commutator and brushes and energize the stator sequentially. Here the conductor is fixed and the magnet moves (Fig. 4.1.5).

The current supplied to the stator is based on the position of rotor. It is switched in sequence using transistors. The position of the rotor is sensed by Hall effect sensors. Thus a continuous rotation is obtained.

**Advantages of brushless DC motor:**

- More precise due to computer control
- More efficient
- No sparking due to absence of brushes
- Less electrical noise
- No brushes to wear out
- Electromagnets are situated on the stator hence easy to cool
- Motor can operate at speeds above 10,000 rpm under loaded and unloaded conditions
- Responsiveness and quick acceleration due to low rotor inertia

**Disadvantages of brushless DC motor:**

- Higher initial cost
- Complex due to presence of computer controller
- Brushless DC motor also requires additional system wiring in order to power the electronic commutation circuitry

**AC motors**

AC motors convert AC current into the rotation of a mechanical element (mechanical energy). As in the case of DC motor, a current is passed through the coil, generating a torque on the coil. Typical components include a stator and a rotor. The armature of rotor is a magnet unlike DC motors and the stator is formed by electromagnets similar to DC motors. The main limitation of AC motors over DC motors is that speed is more difficult to control in AC motors. To overcome this limitation, AC motors are equipped with variable frequency drives but the improved speed control comes together with a reduced power quality.

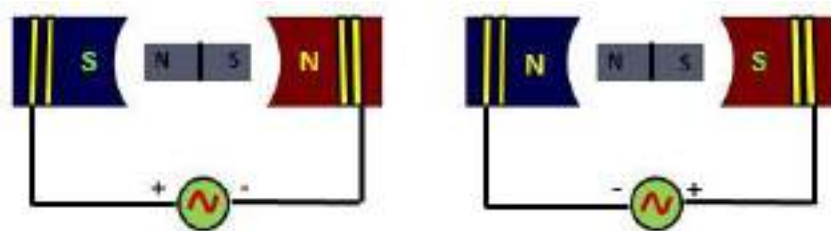


Fig. 4.1.6 AC motor working principle

The working principle of AC motor is shown in fig. 4.1.6. Consider the rotor to be a permanent magnet. Current flowing through conductors energizes the magnets and develops N and S poles. The strength of electromagnets depends on current. First half cycle current flows in one direction and in the second half cycle it flows in opposite direction. As AC voltage changes the poles alternate.

AC motors can be classified into synchronous motors and induction motors.

### Synchronous motor

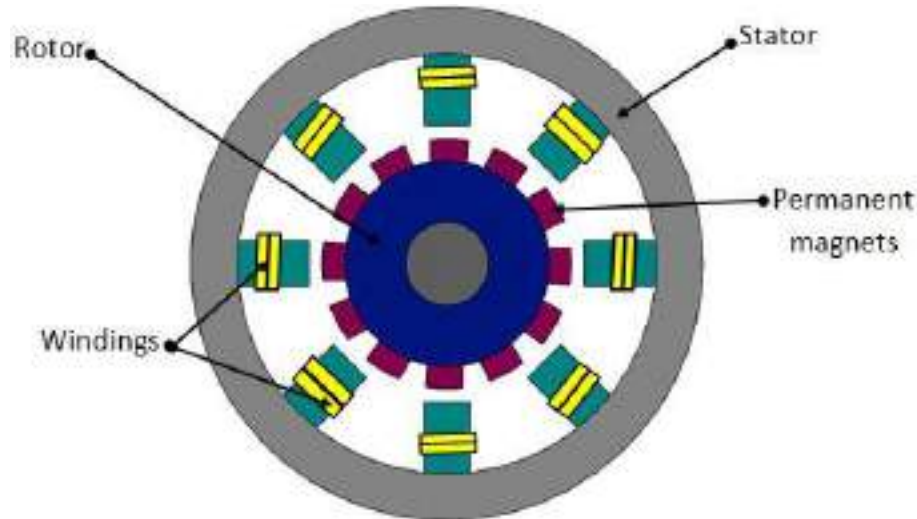


Fig. 4.1.7 Synchronous AC motor

A synchronous motor is an AC motor which runs at constant speed fixed by frequency of the system. It requires direct current (DC) for excitation and has low starting torque, and hence is suited for applications that start with a low load. It has two basic electrical parts namely stator and rotor as shown in fig. 4.1.7. The stator consists of a group of individual wound electro-magnets arranged in such a way that they form a hollow cylinder. The stator produces a rotating magnetic field that is proportional to the frequency supplied. The rotor is the rotating electrical component. It also consists of a group of permanent magnets arranged around a cylinder, with the poles facing toward the stator poles. The rotor is mounted on the motor shaft. The main difference between the synchronous motor and the induction motor is that the rotor of the synchronous motor travels at the same speed as the rotating magnet.

The stator is given a three phase supply and as the polarity of the stator progressively change the magnetic field rotates, the rotor will follow and rotate with the magnetic field of the stator. If a synchronous motor loses lock with the line frequency it will stall. It cannot start by itself, hence has to be started by an auxiliary motor.

Synchronous speed of an AC motor is determined by the following formula:

$$N_s = \frac{120 * f}{P} \quad (4.1.3)$$

$N_s$  = Revolutions per minute

$P$  = Number of pole pairs

$f$  = Applied frequency

### Induction motor

Induction motors are quite commonly used in industrial automation. In the synchronous motor the stator poles are wound with coils and rotor is permanent magnet and is supplied with current to create fixed polarity poles. In case of induction motor, the stator is similar to synchronous motor with windings but the rotors' construction is different.

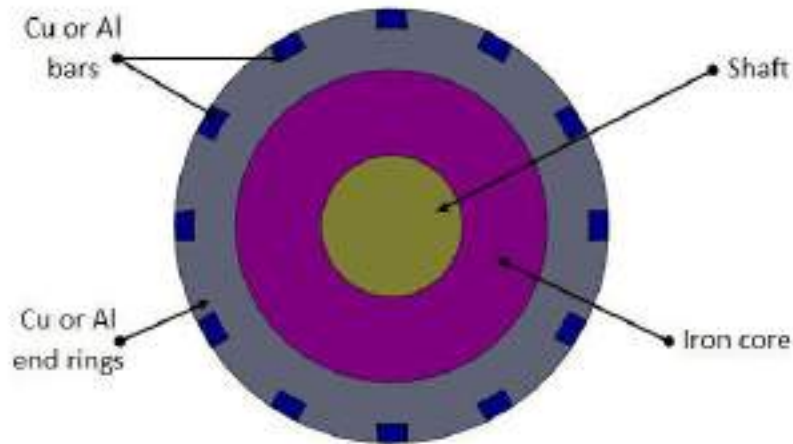


Fig. 4.1.8 Induction motor rotor

Rotor of an induction motor can be of two types:

- A squirrel-cage rotor consists of thick conducting bars embedded in parallel slots. The bars can be of copper or aluminum. These bars are fitted at both ends by means end rings as shown in figure 4.1.8.
- A wound rotor has a three-phase, double-layer, distributed winding. The rotor is wound for as many numbers of poles as the stator. The three phases are wired internally and the other ends are connected to slip-rings mounted on a shaft with brushes resting on them.

Induction motors can be classified into two types:

- *Single-phase induction motor*: It has one stator winding and a squirrel cage rotor. It operates with a single-phase power supply and requires a device to start the motor.
- *Three-phase induction motor*: The rotating magnetic field is produced by the balanced three-phase power supply. These motors can have squirrel cage or wound rotors and are self-starting.

In an induction motor there is no external power supply to rotor. It works on the principle of induction. When a conductor is moved through an existing magnetic field the relative motion of the two causes an electric current to flow in the conductor. In an induction motor the current flow in the rotor is not caused by any direct connection of the conductors to a voltage source, but rather by the influence of the rotor conductors cutting across the lines of flux produced by the stator magnetic fields. The induced current which is produced in the rotor results in a magnetic field around the rotor. The magnetic field around each rotor conductor will cause the rotor conductor to act like the permanent



magnet. As the magnetic field of the stator rotates, due to the effect of the three-phase AC power supply, the induced magnetic field of the rotor will be attracted and will follow the rotation. However, to produce torque, an induction motor must suffer from slip. Slip is the result of the induced field in the rotor windings lagging behind the rotating magnetic field in the stator windings. The slip is given by,

$$s = \frac{n_s - n_r}{n_s} \quad (4.14)$$

***Advantages of AC induction motors***

- It has a simple design, low initial cost, rugged construction almost unbreakable
- The operation is simple with less maintenance (as there are no brushes)
- The efficiency of these motors is very high, as there are no frictional losses, with reasonably good power factor
- The control gear for the starting purpose of these motors is minimum and thus simple and reliable operation

***Disadvantages of AC induction motors***

- The speed control of these motors is at the expense of their efficiency
- As the load on the motor increases, the speed decreases
- The starting torque is inferior when compared to DC motors

### 3.9 Principle of Stepper Motors & servomotors

#### *Stepper motor*

A stepper motor is a pulse-driven motor that changes the angular position of the rotor in steps. Due to this nature of a stepper motor, it is widely used in low cost, open loop position control systems.

Types of stepper motors:

- Permanent Magnet
  - Employ permanent magnet
  - Low speed, relatively high torque
- Variable Reluctance
  - Does not have permanent magnet
  - Low torque

#### **Variable Reluctance Motor**

Figure 4.2.1 shows the construction of Variable Reluctance motor. The cylindrical rotor is made of soft steel and has four poles as shown in Fig.4.2.1. It has four rotor teeth,  $90^\circ$  apart and six stator poles,  $60^\circ$  apart. Electromagnetic field is produced by activating the stator coils in sequence. It attracts the metal rotor. When the windings are energized in a reoccurring sequence of 2, 3, 1, and so on, the motor will rotate in a  $30^\circ$  step angle. In the non-energized condition, there is no magnetic flux in the air gap, as the stator is an electromagnet and the rotor is a piece of soft iron; hence, there is no detent torque. This type of stepper motor is called a variable reluctance stepper.

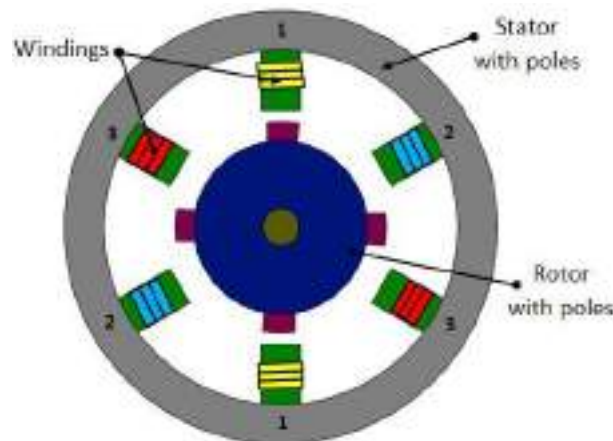


Fig. 4.2.1 Variable reluctance stepper motor

## Permanent magnet (PM) stepper motor

In this type of motor, the rotor is a permanent magnet. Unlike the other stepping motors, the PM motor rotor has no teeth and is designed to be magnetized at a right angle to its axis. Figure 4.2.2 shows a simple,  $90^\circ$  PM motor with four phases (A-D). Applying current to each phase in sequence will cause the rotor to rotate by adjusting to the changing magnetic fields. Although it operates at fairly low speed, the PM motor has a relatively high torque characteristic. These are low cost motors with typical step angle ranging between  $7.5^\circ$  to  $15^\circ$ .

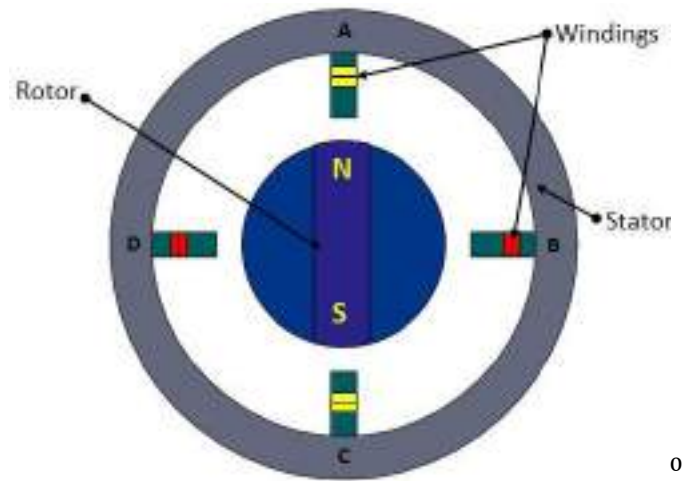


Fig. 4.2.2 Permanent magnet stepper

## Hybrid stepper motor

Hybrid stepping motors combine a permanent magnet and a rotor with metal teeth to provide features of the variable reluctance and permanent magnet motors together. The number of rotor pole pairs is equal to the number of teeth on one of the rotor's parts. The hybrid motor stator has teeth creating more poles than the main poles windings (Fig. 4.2.3).

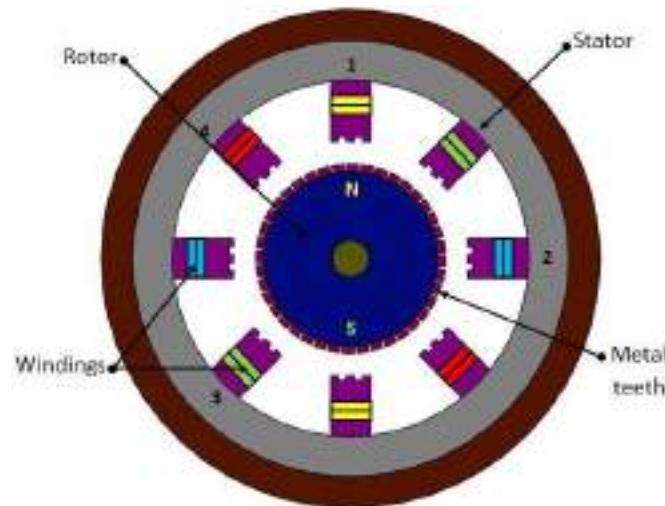


Fig. 3 Hybrid stepper motor

Rotation of a hybrid stepping motor is produced in the similar fashion as a permanent magnet stepping motor, by energizing individual windings in a positive or negative direction. When a winding is energized, north and south poles are created, depending on the polarity of the current flowing. These generated poles attract the permanent poles of the rotor and also the finer metal teeth present on rotor. The rotor moves one step to align the offset magnetized rotor teeth to the corresponding energized windings. Hybrid motors are more expensive than motors with permanent magnets, but they use smaller steps, have greater torque and maximum speed.

Step angle of a stepper motor is given by,

$$\text{Step angle} = \frac{360^\circ}{\text{Number of poles}} \quad (4.2.1)$$

### *Advantages of stepper motors*

- Low cost
- Ruggedness
- Simplicity of construction
- Low maintenance
- Less likely to stall or slip
- Will work in any environment
- Excellent start-stop and reversing responses

### *Disadvantages of stepper motors*

- Low torque capacity compared to DC motors
- Limited speed
- During overloading, the synchronization will be broken. Vibration and noise occur when running at high speed.

### *Servomotor*

Servomotors are special electromechanical devices that produce precise degrees of rotation. A servo motor is a DC or AC or brushless DC motor combined with a position sensing device. Servomotors are also called control motors as they are involved in controlling a mechanical system. The servomotors are used in a closed-loop servo system as shown in Figure 4.2.4. A reference input is sent to the servo amplifier, which controls the speed of the servomotor. A feedback device is mounted on the machine, which is either an encoder or resolver. This device changes mechanical motion into electrical signals and is used as a feedback. This feedback is sent to the error detector, which compares the actual operation with that of the reference input. If there is an error, that error is fed directly to the amplifier, which will be used to make necessary corrections in control action. In many servo systems, both velocity and position are monitored. Servomotors provide accurate speed, torque, and have ability of direction control.

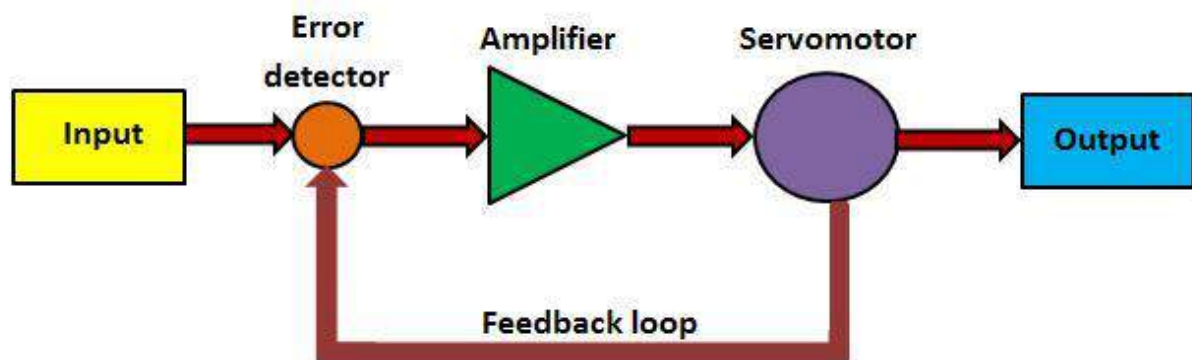


Fig. 4.2.4 Servo system block diagram

### **DC servomotors**

DC operated servomotors usually respond to error signal abruptly and accelerate the load quickly. A DC servo motor is actually an assembly of four separate components, namely:

- DC motor
- gear assembly
- position-sensing device
- control circuit

## **AC servo motor**

In this type of motor, the magnetic force is generated by a permanent magnet and current which further produce the torque. It has no brushes so there is little noise/vibration. This motor provides high precision control with the help of high resolution encoder. The stator is composed of a core and a winding. The rotor part comprises of shaft, rotor core and a permanent magnet.

Digital encoder can be of optical or magnetic type. It gives digital signals, which are in proportion of rotation of the shaft. The details about optical encoder have already discussed in Lecture 3 of Module 2.

### ***Advantages of servo motors***

- Provides high intermittent torque, high torque to inertia ratio, and high speeds
- Work well for velocity control
- Available in all sizes
- Quiet in operation
- Smoother rotation at lower speeds

### ***Disadvantages of servo motors***

- More expensive than stepper motors
- Require tuning of control loop parameters
- Not suitable for hazardous environments or in vacuum
- Excessive current can result in partial demagnetization of DC type servo motor

## **COURSE OUTCOME**

Students will

1. Understand the concept and working of Mechanical and electrical actuation systems
2. Learn the various types of mechanisms and switches
3. Know the concept and working of motors

## **SELF ASSESSMENT QUESTIONS**

1. With a neat block diagram explain Cams.
2. What does Servo and Induction motor consists
3. Draw stepper motors.
4. Explain the concept of solenoids.
5. Explain the main features and functions of relays.

## **FURTHER READING**

1. Mechatronics and microprocessor, Dr H.D.Ramachandra, Sudha Publications, Bangalore, 2018

# **Module 5:**

## **Pneumatic and hydraulic actuation systems, DCV & FCV**

### CONTENTS

#### **Pneumatic and hydraulic actuation systems**

- 5.1 Pneumatic and hydraulic systems
- 5.2 Classifications of Valves, Pressure relief valves, Pressure regulating/reducing valves
- 5.3 Cylinders and rotary actuators

#### **DCV & FCV**

- 5.4 Principle & construction details Symbols of hydraulic elements, components of hydraulic system, and functions of various units of hydraulic system
- 5.5 spool valve solenoid operated
- 5.6 Design of simple hydraulic circuits for various applications

#### **OBJECTIVE**

- Is to understand concepts and working of Pneumatic and hydraulic actuation systems.
- Is to understand concepts and working of direction control valves and flow control valves



## 5.1 Pneumatic and hydraulic systems

### Pneumatic Systems

#### Compressors

##### 1. Diaphragm compressor

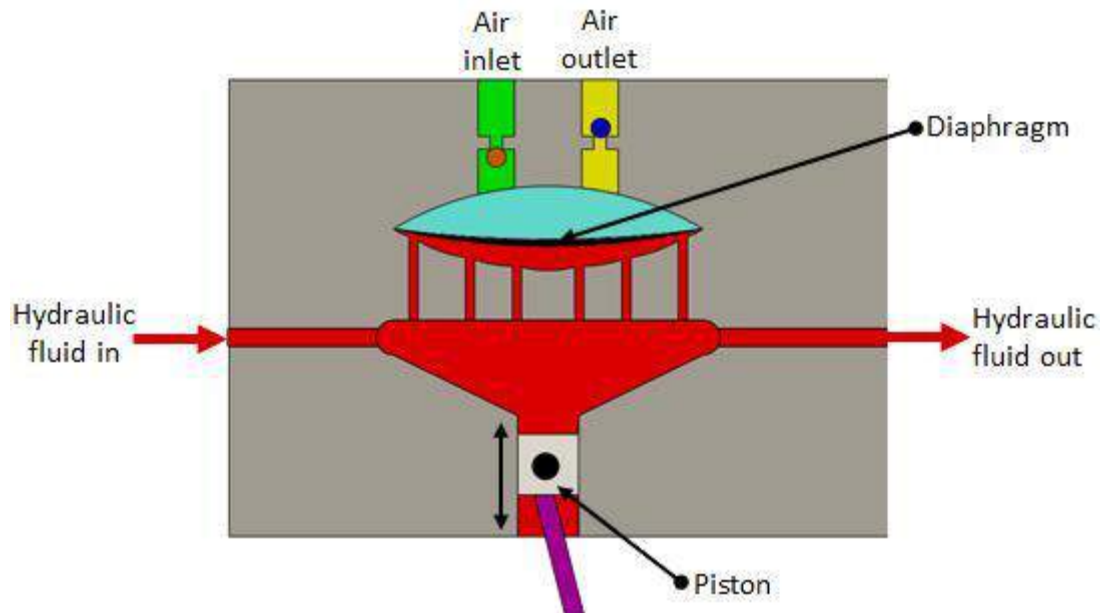


Fig. 5.1.1 Diaphragm compressor

These are small capacity compressors. In piston compressors the lubricating oil from the pistons walls may contaminate the compressed air. The contamination is undesirable in food, pharmaceutical and chemical industries. For such applications diaphragm type compressor can be used. Figure 5.1.1 shows the construction of Diaphragm compressor. The piston reciprocates by a motor driven crankshaft. As the piston moves down it pulls the hydraulic fluid down causing the diaphragm to move along and the air is sucked in. When the piston moves up the fluid pushes the diaphragm up causing the ejection of air from the outlet port. Since the flexible diaphragm is placed in between the piston and the air no contamination takes place.

## 2. Screw compressor

Piston compressors are used when high pressures and relatively low volume of air is needed. The system is complex as it has many moving parts. For medium flow and pressure applications, screw compressor can be used. It is simple in construction with less number of moving parts. The air delivered is steady with no pressure pulsation. It has two meshing screws. The air from the inlet is trapped between the meshing screws and is compressed. The contact between the two meshing surface is minimum, hence no cooling is required. These systems are quite in operation compared to piston type. The screws are synchronized by using external timing gears.

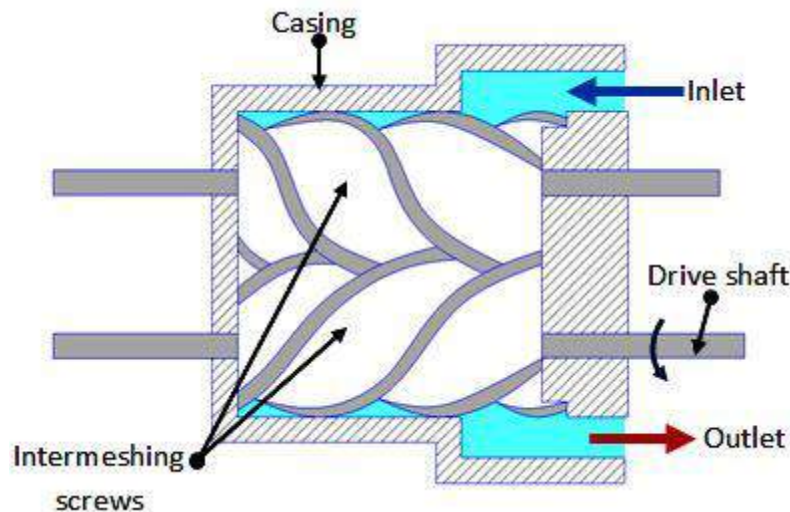


Fig. 5.1.2 Screw compressor

## 3. Rotary vane compressors

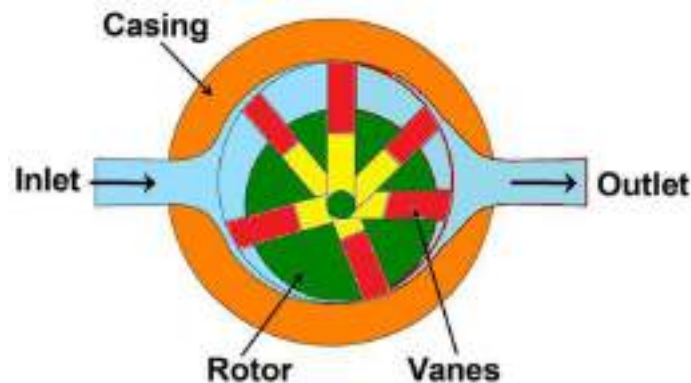


Fig. 5.1.3 Rotary vane compressor

The principle of operation of vane compressor is similar to the hydraulic vane pump. Figure 5.1.3 shows the working principle of Rotary vane compressor. The unbalanced vane compressor consists of spring loaded vanes seating in the slots of the rotor. The pumping action occurs due to movement of the vanes along a cam ring. The rotor is eccentric to the cam ring. As the rotor rotates, the vanes follow the inner surface of the cam ring. The space between the vanes decreases near the outlet due to the eccentricity. This causes compression of the air. These compressors are free from pulsation. If the eccentricity is zero no flow takes place.

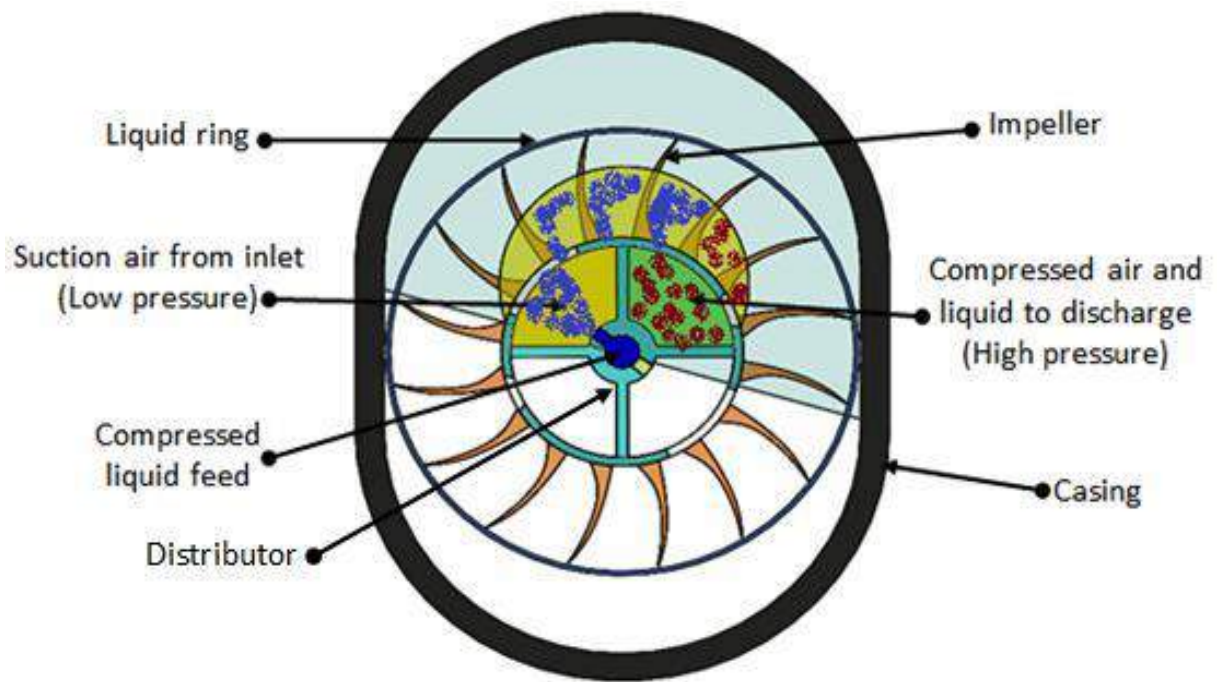


Fig. 5.1.4 Liquid ring compressor

Liquid ring vane compressor is a variation of vane compressors. Figure 5.1.4 shows the construction of Liquid ring compressor. The casing is filled with liquid up to rotor center. The air enters the compressor through the distributor fixed to the compressor. During the impeller rotation, the liquid will be centrifuged along the inner ring of the casing to form the liquid ring. There are two suction and discharge ports provided in the distributor. During the first quarter of cycle, the air is sucked in both suction chambers of the casing and during the second quarter of the cycle, the air is compressed and pushed out through the two discharge ports. During the third and fourth quarters of the cycle, the process is repeated. This type of compressor has no leakage and has minimal friction. For smooth operation, the rotation speed should be about 3000 rpm. The delivery pressure is low (about 5 bar).

#### 4. Lobe compressor

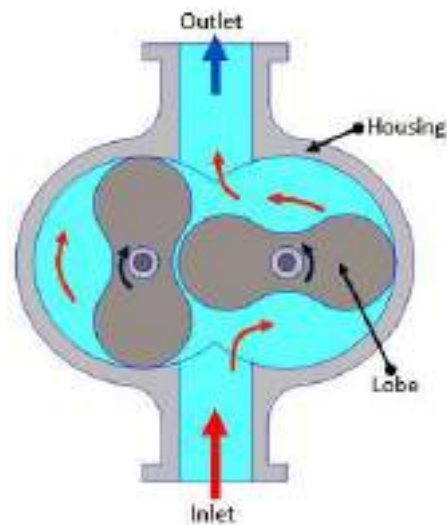


Fig. 5.1.5 Lobe compressor

The lobe compressor is used when high delivery volume but low pressure is needed. It consists of two lobes with one being driven and the other driving. Figure 5.1.5 shows the construction and working of Lobe compressor. It is similar to the Lobe pump used in hydraulic systems. The operating pressure is limited by leakage between rotors and housing. As the wear increases during the operation, the efficiency falls rapidly.

#### 5. Dynamic compressors

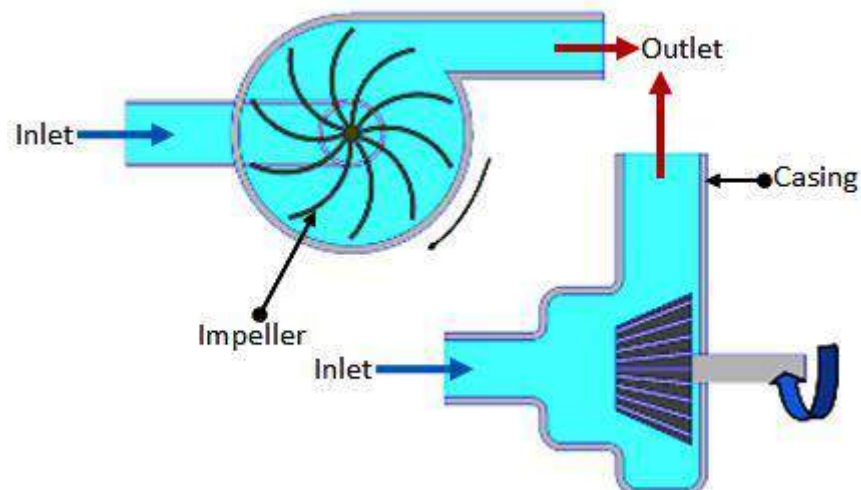


Fig. 5.1.6 Blower (Centrifugal type)

When very large volume of compressed air is required in applications such as ventilators, combustion system and pneumatic powder blower conveyors, the dynamic compressor can be used. The pressure needed is very low in such applications. Figure 5.1.6 shows a typical Centrifugal type blower. The impeller rotates at a high speed. Large volume of low pressure air can be provided by blowers. The blowers draw the air in and the impeller flings it out due to centrifugal force. Positive displacement

compressors need oil to lubricate the moving parts, whereas the dynamic compressors have no such need. The efficiency of these compressors is better than that of reciprocating types.

### ***Classification of Hydraulic Pumps***

These are mainly classified into two categories:

- A. Non-positive displacement pumps
- B. Positive displacement pumps.

#### **A. Non-Positive Displacement Pumps**

These pumps are also known as hydro-dynamic pumps. In these pumps the fluid is pressurized by the rotation of the propeller and the fluid pressure is proportional to the rotor speed. These pumps can not withstand high pressures and generally used for low-pressure and high-volume flow applications. The fluid pressure and flow generated due to inertia effect of the fluid. The fluid motion is generated due to rotating propeller. These pumps provide a smooth and continuous flow but the flow output decreases with increase in system resistance (load). The flow output decreases because some of the fluid slip back at higher resistance. The fluid flow is completely stopped at very large system resistance and thus the volumetric efficiency will become zero. Therefore, the flow rate not only depends on the rotational speed but also on the resistance provided by the system. The important advantages of non-positive displacement pumps are lower initial cost, less operating maintenance because of less moving parts, simplicity of operation, higher reliability and suitability with wide range of fluid etc. These pumps are primarily used for transporting fluids and find little use in the hydraulic or fluid power industries. Centrifugal pump is the common example of non-positive displacement pumps. Details have already discussed in the previous lecture.

#### **B. Positive displacement pump**

These pumps deliver a constant volume of fluid in a cycle. The discharge quantity per revolution is fixed in these pumps and they produce fluid flow proportional to their displacement and rotor speed. These pumps are used in most of the industrial fluid power applications. The output fluid flow is constant and is independent of the system pressure (load). The important advantage associated with these pumps is that the high-pressure and low-pressure areas (means input and output region) are separated and hence the fluid cannot leak back due to higher pressure at the outlets. These features make the positive displacement pump most suited and universally accepted for hydraulic systems. The important advantages of positive displacement pumps over non-positive displacement pumps include capability to generate high pressures, high volumetric efficiency, high

power to weight ratio, change in efficiency throughout the pressure range is small and wider operating range pressure and speed. The fluid flow rate of these pumps ranges from 0.1 and 15,000 gpm, the pressure head ranges between 10 and 100,000 psi and specific speed is less than 500.

It is important to note that the positive displacement pumps do not produce pressure but they only produce fluid flow. The resistance to output fluid flow generates the pressure. It means that if the discharge port (output) of a positive displacement pump is opened to the atmosphere, then fluid flow will not generate any output pressure above atmospheric pressure. But, if the discharge port is partially blocked, then the pressure will rise due to the increase in fluid flow resistance. If the discharge port of the pump is completely blocked, then an infinite resistance will be generated. This will result in the breakage of the weakest component in the circuit. Therefore, the safety valves are provided in the hydraulic circuits along with positive displacement pumps. Important positive displacement pumps are gears pumps, vane pumps and piston pumps. The details of these pumps are discussed in the following sections.

## ***2. Gear Pumps***

Gear pump is a robust and simple positive displacement pump. It has two meshed gears revolving about their respective axes. These gears are the only moving parts in the pump. They are compact, relatively inexpensive and have few moving parts. The rigid design of the gears and houses allow for very high pressures and the ability to pump highly viscous fluids. They are suitable for a wide range of fluids and offer self-priming performance. Sometimes gear pumps are designed to function as either a motor or a pump. These pump includes helical and herringbone gear sets (instead of spur gears), lobe shaped rotors similar to Roots blowers (commonly used as superchargers), and mechanical designs that allow the stacking of pumps. Based upon the design, the gear pumps are classified as:

- External gear pumps
- Lobe pumps
- Internal gear pumps
- Gerotor pumps

Generally gear pumps are used to pump:

- Petrochemicals: Pure or filled bitumen, pitch, diesel oil, crude oil, lube oil etc.
- Chemicals: Sodium silicate, acids, plastics, mixed chemicals, isocyanates etc.
- Paint and ink
- Resins and adhesives
- Pulp and paper: acid, soap, lye, black liquor, kaolin, lime, latex, sludge etc.
- Food: Chocolate, cacao butter, fillers, sugar, vegetable fats and oils, molasses, animal food etc.

## 1 External gear pump

The external gear pump consists of externally meshed two gears housed in a pump case as shown in figure 5.2.1. One of the gears is coupled with a prime mover and is called as driving gear and another is called as driven gear. The rotating gear carries the fluid from the tank to the outlet pipe. The suction side is towards the portion where the gear teeth come out of the mesh. When the gears rotate, volume of the chamber expands leading to pressure drop below atmospheric value. Therefore the vacuum is created and the fluid is pushed into the void due to atmospheric pressure. The fluid is trapped between housing and rotating teeth of the gears. The discharge side of pump is towards the portion where the gear teeth run into the mesh and the volume decreases between meshing teeth. The pump has a positive internal seal against leakage; therefore, the fluid is forced into the outlet port. The gear pumps are often equipped with the side wear plate to avoid the leakage. The clearance between gear teeth and housing and between side plate and gear face is very important and plays an important role in preventing leakage. In general, the gap distance is less than 10 micrometers. The amount of fluid discharge is determined by the number of gear teeth, the volume of fluid between each pair of teeth and the speed of rotation. The important drawback of external gear pump is the unbalanced side load on its bearings. It is caused due to high pressure at the outlet and low pressure at the inlet which results in slower speeds and lower pressure ratings in addition to reducing the bearing life. Gear pumps are most commonly used for the hydraulic fluid power applications and are widely used in chemical installations to pump fluid with a certain viscosity.

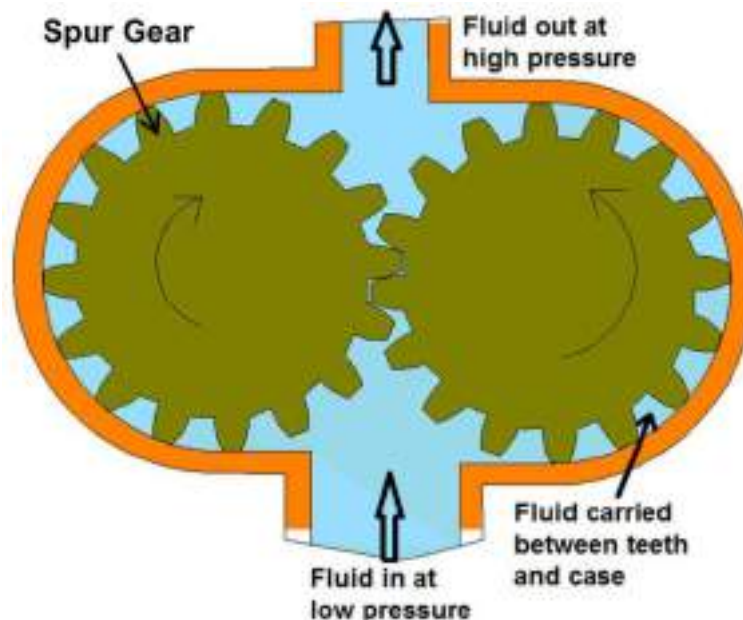


Figure 5.2.1 Gear pump

## 2 Lobe Pump

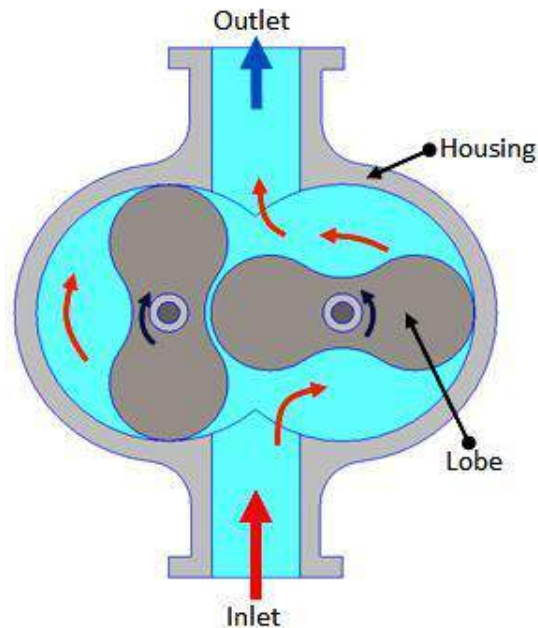


Figure 5.2.2 Lobe pump

Lobe pumps work on the similar principle of working as that of external gear pumps. However in Lobe pumps, the lobes do not make any contact like external gear pump (see Figure 5.2.2). Lobe contact is prevented by external timing gears located in the gearbox. Similar to the external gear pump, the lobes rotate to create expanding volume at the inlet. Now, the fluid flows into the cavity and is trapped by the lobes. Fluid travels around the interior of casing in the pockets between the lobes and the casing. Finally, the meshing of the lobes forces liquid to pass through the outlet port. The bearings are placed out of the pumped liquid. Therefore the pressure is limited by the bearing location and shaft deflection.

Because of superb sanitary qualities, high efficiency, reliability, corrosion resistance and good clean-in-place and steam-in-place (CIP/SIP) characteristics, Lobe pumps are widely used in industries such as pulp and paper, chemical, food, beverage, pharmaceutical and biotechnology etc. These pumps can handle solids (e.g., cherries and olives), slurries, pastes, and a variety of liquids. A gentle pumping action minimizes product degradation. They also offer continuous and intermittent reversible flows. Flow is relatively independent of changes in process pressure and therefore, the output is constant and continuous.

Lobe pumps are frequently used in food applications because they handle solids without damaging the product. Large sized particles can be pumped much effectively than in other positive displacement types. As the lobes do not make any direct contact therefore, the clearance is not as close as in other Positive displacement pumps. This specific design of pump makes it suitable to handle low viscosity fluids with diminished performance.



Loading characteristics are not as good as other designs, and suction ability is low. High-viscosity liquids require reduced speeds to achieve satisfactory performance. The reduction in speed can be 25% or more in case of high viscosity fluid.

### 3 Internal Gear Pump

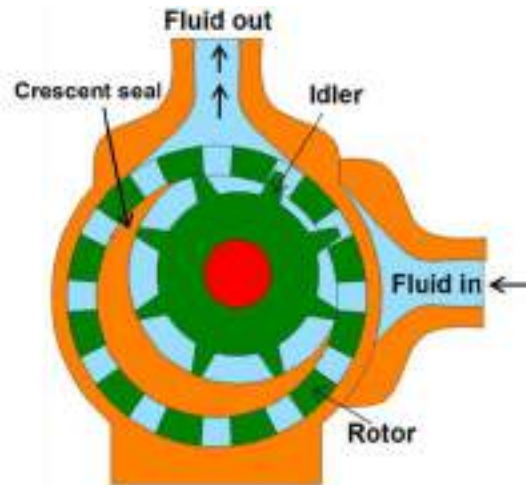


Figure 5.2.3 Internal gear pump

Internal gear pumps are exceptionally versatile. They are often used for low or medium viscosity fluids such as solvents and fuel oil and wide range of temperature. This is non-pulsing, self-priming and can run dry for short periods. It is a variation of the basic gear pump.

It comprises of an internal gear, a regular spur gear, a crescent-shaped seal and an external housing. The schematic of internal gear pump is shown in figure 5.2.3. Liquid enters the suction port between the rotor (large exterior gear) and idler (small interior gear) teeth. Liquid travels through the pump between the teeth and crescent. Crescent divides the liquid and acts as a seal between the suction and discharge ports. When the teeth mesh on the side opposite to the crescent seal, the fluid is forced out through the discharge port of the pump. This clearance between gears can be adjusted to accommodate high temperature, to handle high viscosity fluids and to accommodate the wear. These pumps are bi-rotational so that they can be used to load and unload the vessels. As these pumps have only two moving parts and one stuffing box, therefore they are reliable, simple to operate and easy to maintain. However, these pumps are not suitable for high speed and high pressure applications. Only one bearing is used in the pump therefore overhung load on shaft bearing reduces the life of the bearing.

## Applications

Some common internal gear pump applications are:

- All varieties of fuel oil and lube oil
- Resins and Polymers
- Alcohols and solvents
- Asphalt, Bitumen, and Tar
- Polyurethane foam (Isocyanate and polyol)
- Food products such as corn syrup, chocolate, and peanut butter
- Paint, inks, and pigments
- Soaps and surfactants
- Glycol

## 4 Gerotor Pump

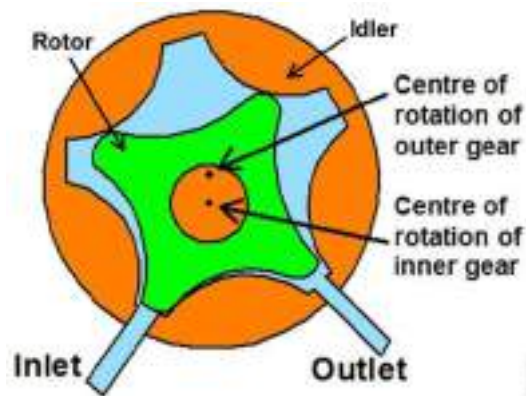


Figure 5.2.4 Gerotor pump

Gerotor is a positive displacement pump. The name Gerotor is derived from "Generated Rotor". At the most basic level, a Gerotor is essentially one that is moved via fluid power. Originally this fluid was water, today the wider use is in hydraulic devices. The schematic of Gerotor pump is shown in figure 5.2.4. Gerotor pump is an internal gear pump without the crescent. It consists of two rotors viz. inner and outer rotor. The inner rotor has  $N$  teeth, and the outer rotor has  $N+1$  teeth. The inner rotor is located off-center and both rotors rotate. The geometry of the two rotors partitions the volume between them into  $N$  different dynamically-changing volumes. During the rotation, volume of each partition changes continuously. Therefore, any given volume first increases, and then decreases. An increase in volume creates vacuum. This vacuum creates suction, and thus, this part of the cycle sucks the fluid. As the volume decreases, compression occurs. During this compression period, fluids can be pumped, or compressed (if they are gaseous fluids).

The close tolerance between the gears acts as a seal between the suction and discharge ports. Rotor and idler teeth mesh completely to form a seal equidistant from the discharge and suction ports. This seal forces the liquid out of the discharge port. The flow output is uniform and constant at the outlets.

The important advantages of the pumps are high speed operation, constant discharge in all pressure conditions, bidirectional operation, less sound in running condition and less maintenance due to only two moving parts and one stuffing box etc. However, the pump is having some limitations such as medium pressure operating range, clearance is fixed, solids can't be pumped and overhung load on the shaft bearing etc.

### **Applications**

Gerotors are widely used in industries and are produced in variety of shapes and sizes by a number of different methods. These pumps are primarily suitable for low pressure applications such as lubrication systems or hot oil filtration systems, but can also be found in low to moderate pressure hydraulic applications. However common applications are as follows:

- Light fuel oils
- Lube oil
- Cooking oils
- Hydraulic fluid

### 3. Vane Pumps

In the previous lecture we have studied the gear pumps. These pumps have a disadvantage of small leakage due to gap between gear teeth and the pump housing. This limitation is overcome in vane pumps. The leakage is reduced by using spring or hydraulically loaded vanes placed in the slots of driven rotor. Capacity and pressure ratings of a vane pump are generally lower than the gear pumps, but reduced leakage gives an improved volumetric efficiency of around 95%.

Vane pumps are available in a number of vane configurations including sliding vane, flexible vane, swinging vane, rolling vane, and external vane etc. Each type of vane pump has its own advantages. For example, external vane pumps can handle large solids. Flexible vane pumps can handle only the small solids but create good vacuum. Sliding vane pumps can run dry for short periods of time and can handle small amounts of vapor. The vane pumps are known for their dry priming, ease of maintenance, and good suction characteristics. The operating range of these pumps varies from  $-32\text{ }^{\circ}\text{C}$  to  $260\text{ }^{\circ}\text{C}$ .

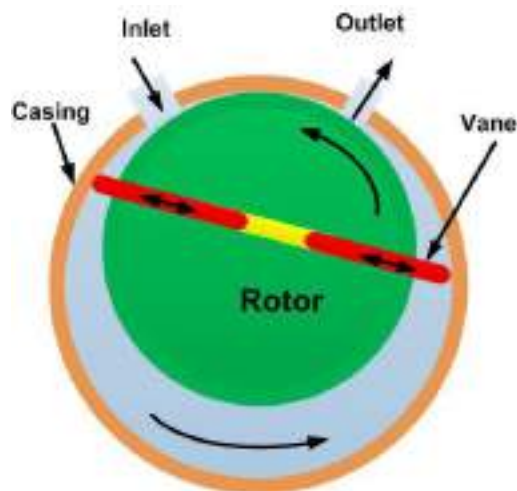


Figure 5.3.1 Schematic of working principle of vane pump

The schematic of vane pump working principle is shown in figure 5.3.1. Vane pumps generate a pumping action by tracking of vanes along the casing wall. The vane pumps generally consist of a rotor, vanes, ring and a port plate with inlet and outlet ports. The rotor in a vane pump is connected to the prime mover through a shaft. The vanes are

located on the slotted rotor. The rotor is eccentrically placed inside a cam ring as shown in the figure. The rotor is sealed into the cam by two side plates. When the prime mover rotates the rotor, the vanes are thrown outward due to centrifugal force. The vanes track along the ring. It provides a tight hydraulic seal to the fluid which is more at the higher rotation speed due to higher centrifugal force. This produces a suction cavity in the ring as the rotor rotates. It creates vacuum at the inlet and therefore, the fluid is pushed into the pump through the inlet. The fluid is carried around to the outlet by the vanes whose retraction causes the fluid to be expelled. The capacity of the pump depends upon the eccentricity, expansion of vanes, width of vanes and speed of the rotor. It can be noted that the fluid flow will not occur when the eccentricity is zero. These pumps can handle thin liquids (low viscosity) at relatively higher pressure. These pumps can be run dry for a small duration without any failure. These pumps develop good vacuum due to negligible leakage. However, these pumps are not suitable for high speed applications and for the high viscosity fluids or fluids carrying some abrasive particles. The maintenance cost is also higher due to many moving parts. These pumps have various applications for the pumping of following fluids:

- Aerosol and Propellants
- Aviation Service - Fuel Transfer, Deicing
- Auto Industry - Fuels, Lubes, Refrigeration Coolants
- Bulk Transfer of LPG and NH<sub>3</sub>
- LPG Cylinder Filling
- Alcohols
- Refrigeration - Freons, Ammonia
- Solvents
- Aqueous solutions

## 1 Unbalanced Vane pump

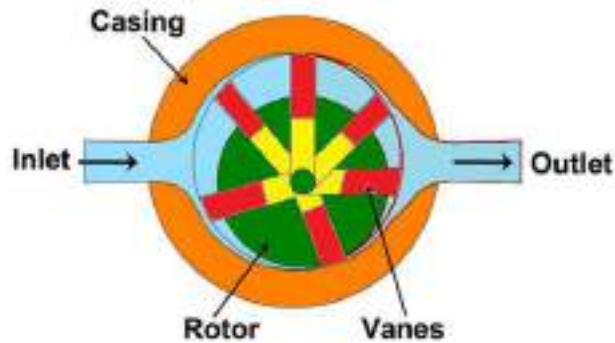


Figure 5.3.2 Unbalanced vane pump

In practice, the vane pumps have more than one vane as shown in figure 5.3.2. The rotor is offset within the housing, and the vanes are constrained by a cam ring as they cross inlet and outlet ports. Although the vane tips are held against the housing, still a small amount of leakage exists between rotor faces and body sides. Also, the vanes compensate to a large degree for wear at the vane tips or in the housing itself. The pressure difference between outlet and inlet ports creates a large amount of load on the vanes and a significant amount of side load on the rotor shaft which can lead to bearing failure. This type of pump is called as unbalanced vane pump.

## 2 Balanced vane pump

Figure 5.3.2 shows the schematic of a balanced vane pump. This pump has an elliptical cam ring with two inlet and two outlet ports. Pressure loading still occurs in the vanes but the two identical pump halves create equal but opposite forces on the rotor. It leads to the zero net force on the shaft and bearings. Thus, lives of pump and bearing increase significantly. Also the sounds and vibrations decrease in the running mode of the pump.

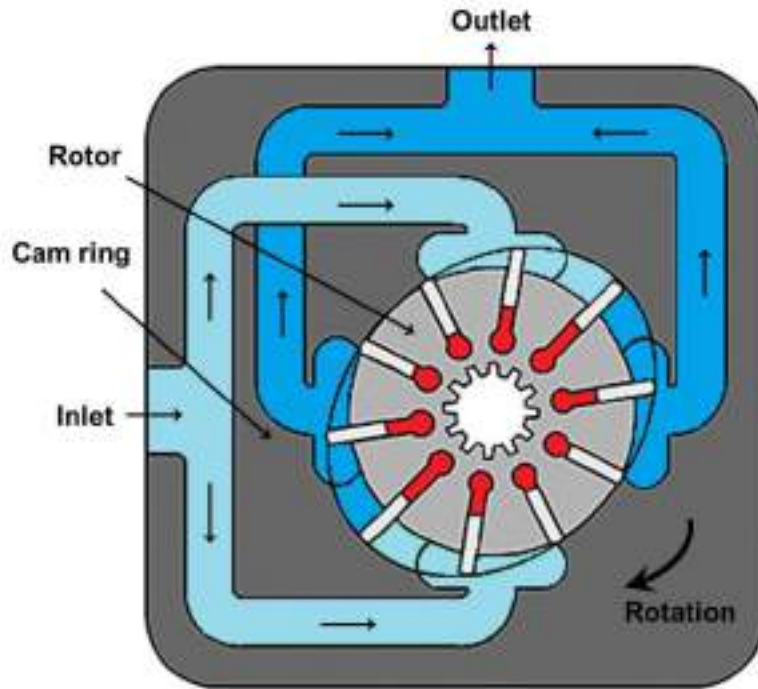


Figure 5.3.2 Balanced Vane Pump

### 3 Adjustable vane pump

The proper design of pump is important and a challenging task. In ideal condition, the capacity of a pump should be exactly same to load requirements. A pump with larger capacity wastes energy as the excess fluid will pass through the pressure relief valve. It also leads to a rise in fluid temperature due to energy conversion to the heat instead of useful work and therefore it needs some external cooling arrangement. Therefore, the higher capacity pump increases the power consumption and makes the system bulky and costly. Pumps are generally available with certain standard capacities and the user has to choose the next available capacity of the pump. Also, the flow rate from the pump in most hydraulic applications needs to be varying as per the requirements. Therefore, some vane pumps are also available with adjustable capacity as shown in figure 5.3.4. This can be achieved by adjusting a positional relationship between rotor and the inner casing by the help of an external controlling screw. These pumps basically consist of a rotor, vanes, cam ring, port plate, thrust bearing for guiding the cam ring and a discharge control screw by which the position of the cam ring relative to the rotor can be varied. In general, the adjustable vane pumps are unbalanced pump type.

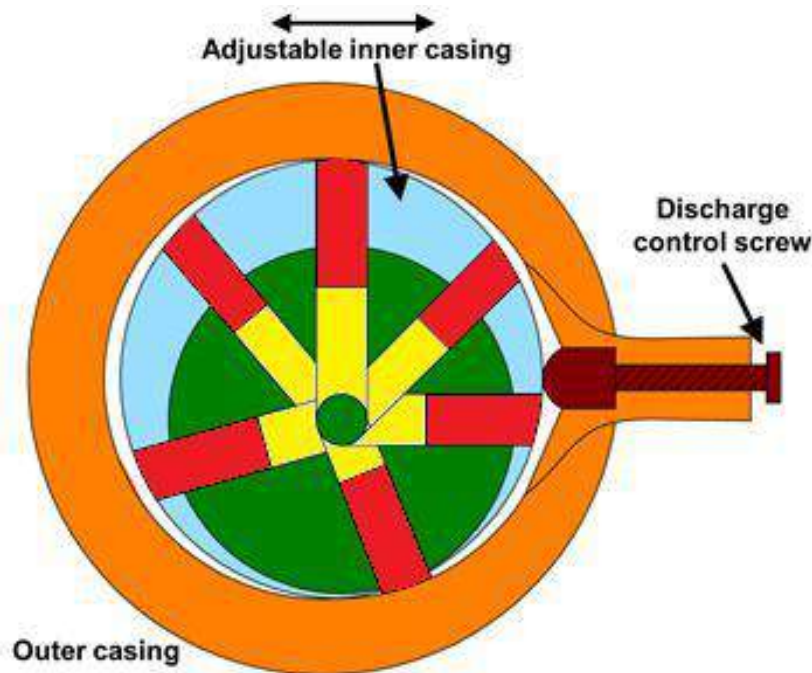


Figure 5.3.3 Adjustable vane pump

The amount of fluid that is displaced by a vane pump running at a constant speed is determined by the maximum extension of the vanes and the vanes width. However, for a pump running in operation, the width of vanes cannot be changed but the distance by which the vanes are extended can be varied. This is possible by making a provision for changing the position of the cam ring (adjustable inner casing) relative to the rotor as shown in figure 5.3.4. The eccentricity of rotor with respect to the cam ring is adjusted by



the movement of the screw. The delivery volume increases with increase in the eccentricity. This kind of arrangement can be used to achieve a variable volume from the pump and is known as variable displacement vane pump.

In general, the adjusted vane pumps are pressure compensated. It means that the discharge is controlled by pre-adjusted value and when the discharge pressure reaches a certain (adjusted) value; the pumping action ceases. This mechanism is accomplished by using a compensating spring to offset the cam ring. Initially, the eccentricity is maximum because the discharge pressure is zero and spring force keeps the cam ring at the extreme right position. As the discharge pressure increases, it acts on the inner contour of the cam ring. It pushes the cam ring towards the left against the spring force and hence the eccentricity reduces and hence the discharge through the pump reduces. When the discharge pressure becomes high enough to overcome the entire spring force; the compensator spring will compress until the zero eccentricity is achieved. In this condition, the pumping action ceases and the fluid flow (except small leakages) does not occur. Therefore, the system pressure can be adjusted by setting the compensator spring. These pumps ensure their own protection against excessive system pressure and do not rely on the safety control devices of the hydraulic system. These pumps are used as energy savings devices and have been used in many applications, including automotive transmissions.

#### ***4 Piston pumps***

Piston pumps are meant for the high-pressure applications. These pumps have high-efficiency and simple design and needs lower maintenance. These pumps convert the rotary motion of the input shaft to the reciprocating motion of the piston. These pumps work similar to the four stroke engines. They work on the principle that a reciprocating piston draws fluid inside the cylinder when the piston retracts in a cylinder bore and discharge the fluid when it extends. Generally, these pumps have fixed inclined plate or variable degree of angle plate known as swash plate (shown in Figure 5.3.4 and Figure 5.3.6). When the piston barrel assembly rotates, the swash plate in contact with the piston slippers slides along its surface. The stroke length (axial displacement) depends on the inclination angle of the swash plate. When the swash plate is vertical, the reciprocating motion does not occur and hence pumping of the fluid does not take place. As the swash plate angle increases, the piston reciprocates inside the cylinder barrel. The stroke length increases with increase in the swash plate angle and therefore volume of pumping fluid increases. During one half of the rotation cycle, the pistons move out of the cylinder barrel and the volume of the barrel increases. During another half of the rotation, the pistons move into the cylinder barrel and the barrel volume decreases. This phenomenon is responsible for drawing the fluid in and pumping it out. These pumps are positive displacement pump and can be used for both liquids and gases. Piston pumps are basically of two types:

- i. Axial piston pumps
- ii. Radial piston pumps

## 1 Axial Piston Pump

Axial piston pumps are positive displacement pumps which convert rotary motion of the input shaft into an axial reciprocating motion of the pistons. These pumps have a number of pistons (usually an odd number) in a circular array within a housing which is commonly referred to as a cylinder block, rotor or barrel. These pumps are used in jet aircraft. They are also used in small earthmoving plants such as skid loader machines. Another use is to drive the screws of torpedoes. In general, these systems have a maximum operating temperature of about 120 °C. Therefore, the leakage between cylinder housing and body block is used for cooling and lubrication of the rotating parts. This cylinder block rotates by an integral shaft aligned with the pistons. These pumps have sub-types as:

- a. Bent axis piston pumps
- b. Swash plate axial piston pump

### 1 Bent-Axis Piston Pumps

Figure 5.3.5 shows the schematic of bent axis piston pump. In these pumps, the reciprocating action of the pistons is obtained by bending the axis of the cylinder block. The cylinder block rotates at an angle which is inclined to the drive shaft. The cylinder block is turned by the drive shaft through a universal link. The cylinder block is set at an offset angle with the drive shaft. The cylinder block contains a number of pistons along its periphery. These piston rods are connected with the drive shaft flange by ball-and-socket joints. These pistons are forced in and out of their bores as the distance between the drive shaft flange and the cylinder block changes. A universal link connects the block to the drive shaft, to provide alignment and a positive drive.

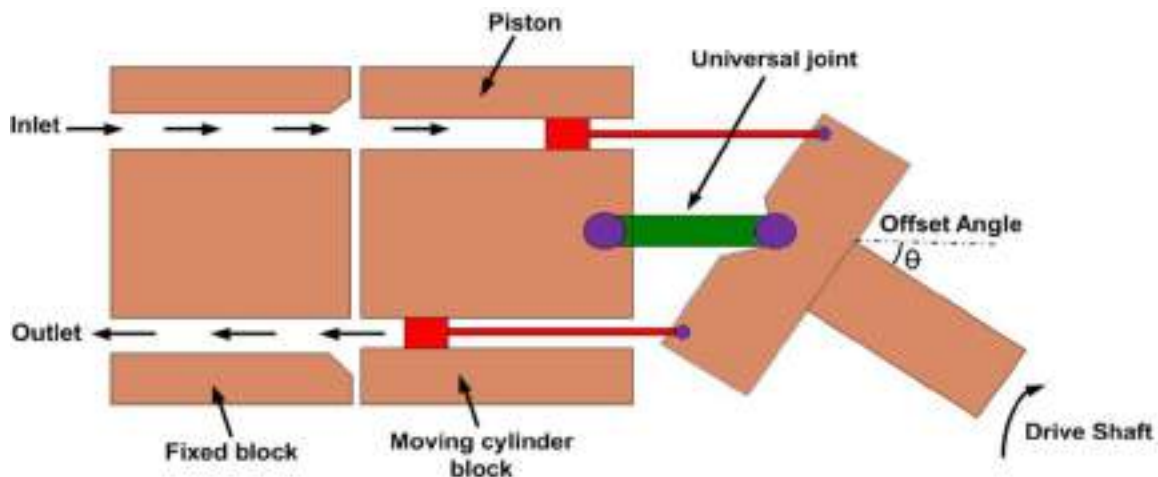


Figure 5.3.5 Bent axis piston pump

The volumetric displacement (discharge) of the pump is controlled by changing the offset angle. It makes the system simple and inexpensive. The discharge does not occur when the cylinder block is parallel to the drive shaft. The offset angle can vary from  $0^\circ$  to  $40^\circ$ . The fixed displacement units are usually provided with  $23^\circ$  or  $30^\circ$  offset angles while the variable displacement units are provided with a yoke and an external control mechanism to change the offset angle. Some designs have arrangement of moving the yoke over the center position to reverse the fluid flow direction. The flow rate of the pump varies with the offset angle  $\theta$ . There is no flow when the cylinder block centerline is parallel to the drive shaft centerline (offset angle is  $0^\circ$ ). The total fluid flow per stroke can be given as:

$$V_d = nAD \tan\theta$$

(5.3.1)

The flow rate of the pump can be given as:

$$V_d = nADN \tan\theta$$

(5.3.2)

here,  $\tan\theta = \frac{S}{D}$

where  $S$  is the piston stroke,  $D$  is piston diameter,  $n$  is the number of pistons,  $N$  is the speed of pump and  $A$  is the area of piston.

## 6 Swash Plate Axial Piston Pump

A swash plate is a device that translates the rotary motion of a shaft into the reciprocating motion. It consists of a disk attached to a shaft as shown in Figure 5.3.6. If the disk is aligned perpendicular to the shaft; the disk will turn along with the rotating shaft without any reciprocating effect. Similarly, the edge of the inclined shaft will appear to oscillate along the shaft's length. This apparent linear motion increases with increase in the angle between disk and the shaft (offset angle). The apparent linear motion can be converted into an actual reciprocating motion by means of a follower that does not turn with the swash plate.

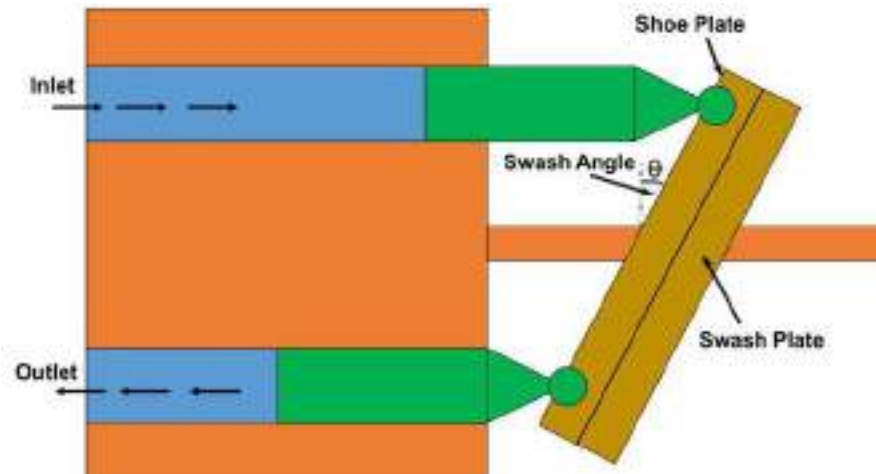


Figure 5.3.6 Swash plate piston pump

In swash plate axial piston pump a series of pistons are aligned coaxially with a shaft through a swash plate to pump a fluid. The schematic of swash plate piston pump is shown in Figure 5.3.6. The axial reciprocating motion of pistons is obtained by a swash plate that is either fixed or has variable degree of angle. As the piston barrel assembly rotates, the piston rotates around the shaft with the piston shoes in contact with the swash plate. The piston shoes follow the angled surface of the swash plate and the rotational motion of the shaft is converted into the reciprocating motion of the pistons. When the swash plate is perpendicular to the shaft; the reciprocating motion to the piston does not occur. As the swash plate angle increases, the piston follows the angle of the swash plate surface and hence it moves in and out of the barrel. The piston moves out of the cylinder barrel during one half of the cycle of rotation thereby generating an increasing volume, while during other half of the rotating cycle, the pistons move into the cylinder barrel generating a decreasing volume. This reciprocating motion of the piston results in the drawing in and pumping out of the fluid. Pump capacity can be controlled by varying the swash plate angle with the help of a separate hydraulic cylinder. The pump capacity (discharge) increases with increase in the swash plate angle and vice-versa. The cylinder block and the drive shaft in this pump are located on the same centerline. The pistons are connected through shoes and a shoe plate that bears against the swash plate. These pumps can be designed to have a variable displacement capability. It can be done by mounting

the swash plate in a movable yoke. The swash plate angle can be changed by pivoting the yoke on pintles.

## 7 Radial Piston Pump

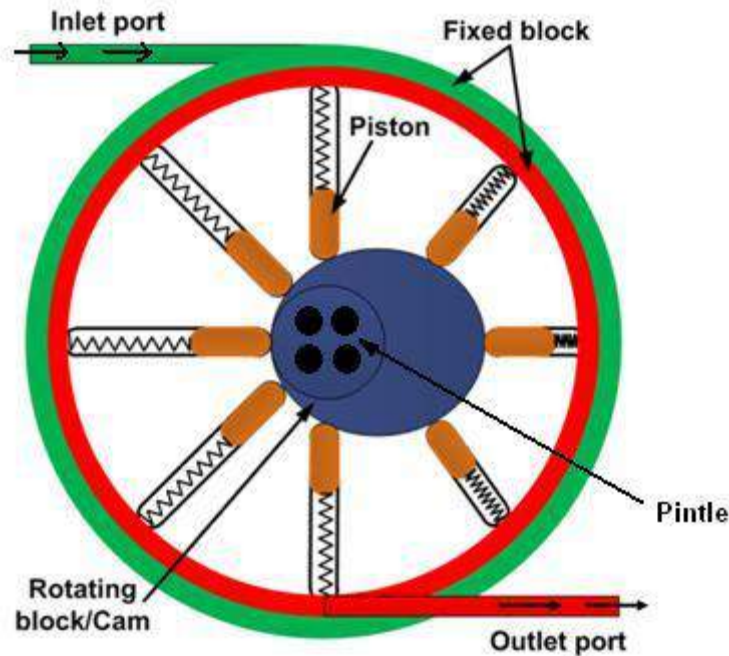


Figure 5.3.7 Radial piston pump

The typical construction of radial piston pump is shown in Figure 5.3.7. The piston pump has pistons aligned radially in a cylindrical block. It consists of a pintle, a cylinder barrel with pistons and a rotor containing a reaction ring. The pintle directs the fluid in and out of the cylinder. Pistons are placed in radial bores around the rotor. The piston shoes ride on an eccentric ring which causes them to reciprocate as they rotate. The eccentricity determines the stroke of the pumping piston. Each piston is connected to inlet port when it starts extending while it is connected to the outlet port when start retracting. This connection to the inlet and outlet port is performed by the timed porting arrangement in the pintle. For initiating a pumping action, the reaction ring is moved eccentrically with respect to the pintle or shaft axis. As the cylinder barrel rotates, the pistons on one side travel outward. This draws the fluid in as the cylinder passes the suction port of the pintle. It is continued till the maximum eccentricity is reached. When the piston passes the maximum eccentricity, pintle is forced inwards by the reaction ring. This forces the fluid to flow out of the cylinder and enter in the discharge (outlet) port of the pintle.

The radial piston pump works on high pressure (up to 1000 bar). It is possible to use the pump with various hydraulic fluids like mineral oil, biodegradable oil, HFA (oil in water), HFC (water-glycol), HFD (synthetic ester) or cutting emulsion. This is because the parts are hydrostatically balanced. It makes the pump suitable for the many applications such as machine tools (displace of cutting emulsion, supply for hydraulic equipment like cylinders), high pressure units (overload protection of presses), test rigs,

automotive sector (automatic transmission, hydraulic suspension control in upper-class cars), plastic (powder injection molding) and wind energy etc.

### 3. Combination Pump

There are two basic requirements for load lifting or load applying by a hydraulic ram. First, there is a need of large volume of fluid at a low pressure when the cylinder extends or retracts. The low pressure is required to overcome the frictional resistance. The second requirement is that a high pressure is needed, when the load is gripped.

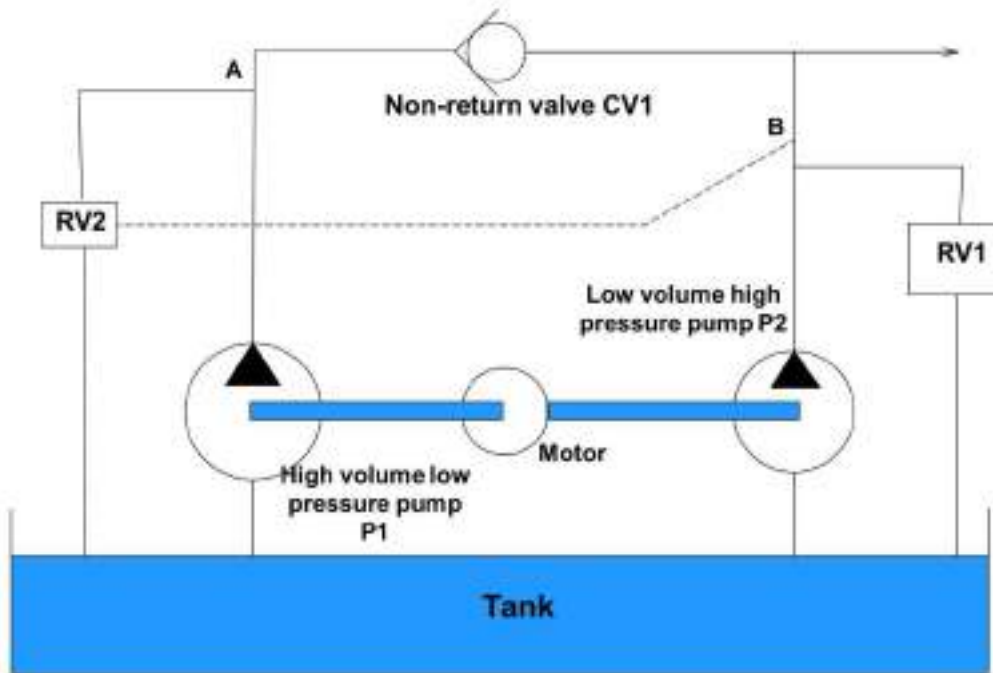


Figure 5.3.8 Combination pump

This type of requirements can be fulfilled by an arrangement as shown in figure 5.3.8. In this system two separate pumps are driven by a common electrical motor. Pump P1 is a high pressure low volume pump and pump P2 is a high volume low pressure pump. The hydraulic system is associated with relief valves RV1 and RV2 and a one-way check valve CV1. This kind of arrangement allows the fluid flow from left to right, but blocks in the reverse direction.

The pressure relief valve RV1 is a normal high pressure valve. The pressure relief valve RV2 is not operated by the pressure at point A, however, it is remotely operated by the pressure at point B. This can be achieved with the balanced piston valve. In low pressure mode both relief valves are closed and both pumps P1 and P2 deliver fluid to the load but the majority comes from the pump P2 as its capacity is higher.

When the load is in the holding mode, the pressure at B rises and relief valve RV2 opens. It results in all the fluid from pump P2 to return straight to the tank directly and the pressure at A to fall to a low value. The check valve CV1 stops the fluid from pump P1

pass it back to the tank via relief valve RV2, consequently pressure at B rises to the level set by relief valve RV1.

This kind of arrangement saves energy as the large volume of fluid from pump P2 is returned to the tank at a very low pressure, and only a small volume of fluid from pump P1 is returned at a high pressure.

**In general the applications of Hydraulic Pumps can be summarized as,**

- Hydraulic pumps are used to transfer power via hydraulic liquid. These pumps have a number of applications in automobiles, material handling systems, automatic transmissions, controllers, compressors and household items.
- The hand operated hydraulic pump is used in a hydraulic jack where many strokes of the pump apply hydraulic pressure to lift the ram.
- A backhoe uses an engine driven hydraulic pump to drive the articulating parts of the mechanical hoe.
- The hydraulic pumps are commonly used in the automotive vehicles especially in power steering systems.
- The lift system of tractor is operated by the hydraulic pumps. These are used in automatic transmissions and material handling systems in industries.
- Many precise controllers are developed by using hydraulic pumps. The commonly used compressor is operated by reciprocating pumps.
- The hydraulic pumps are also used in routine household systems like power lift and air-conditions. Therefore, it can be said that the hydraulic pumps have significant applications in industries as well as ones routine life.

## **5.2 Classifications of Valves, Pressure relief valves, Pressure regulating/reducing valves**

In a hydraulic system, the hydraulic energy available from a pump is converted into motion and force by means of an actuator. The control of these mechanical outputs (motion and force) is one of the most important functions in a hydraulic system. The proper selection of control selection ensures the desired output and safe function of the system. In order to control the hydraulic outputs, different types of control valves are required. It is important to know various types of control valves and their functions. This not only helps to design a proper hydraulic system but also helps to discover the innovative ways to improve the existing systems. In this lecture and next few lectures, various types of valves will be discussed.

There are basically three types of valves employed in hydraulic systems:

1. Directional control valves
2. Flow control valves
3. Pressure control valves

## ***1. Direction control valve***

Directional control valves are used to control the distribution of energy in a fluid power system. They provide the direction to the fluid and allow the flow in a particular direction. These valves are used to control the start, stop and change in direction of the fluid flow. These valves regulate the flow direction in the hydraulic circuit. These control valves contain ports that are external openings for the fluid to enter and leave. The number of ports is usually identified by the term 'way'. For example, a valve with four ports is named as four-way valve. The fluid flow rate is responsible for the speed of actuator (motion of the output) and should be controlled in a hydraulic system. This operation can be performed by using flow control valves. The pressure may increase gradually when the system is under operation. The pressure control valves protect the system by maintaining the system pressure within the desired range. Also, the output force is directly proportional to the pressure and hence, the pressure control valves ensure the desired force output at the actuator.

Directional control valves can be classified in the following manner:

1. Type of construction:
  - Poppet valves
  - Spool valves



2. Number of ports:
  - Two- way valves
  - Three – way valves
  - Four- way valves.
3. Number of switching position:
  - Two – position
  - Three - position
4. Actuating mechanism:
  - Manual actuation
  - Mechanical actuation
  - Solenoid actuation
  - Hydraulic actuation
  - Pneumatic actuation
  - Indirect actuation

## 1.1 Type of construction

### 1.1.1 Check Valves

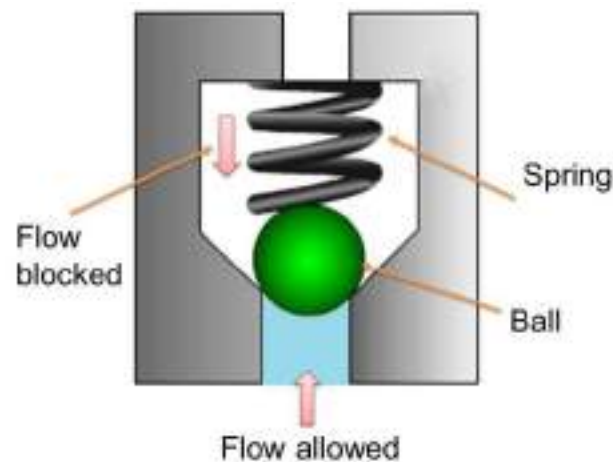


Figure 5.2.1 Inline check valve

These are unidirectional valves and permit the free flow in one direction only. These valves have two ports: one for the entry of fluid and the other for the discharge. They consist of a housing bore in which a ball or poppet is held by a small spring force. The valve having a ball as a closing member is known as a ball check valve. Various types of check valves are available for a range of applications. These valves are generally small sized, simple in construction and inexpensive. Generally, check valves are automatically operated. Human intervention or any external control system is not

required. These valves can wear out or can generate the cracks after prolonged usage and therefore they are mostly made of plastics for easy repair and replacements.

An important concept in check valves is the cracking pressure. The check valve is designed for a specific cracking pressure which is the minimum upstream pressure at which the valve operates. The simplest check valve is an inline check valve as shown in Figure 5.2.1. The ball is held against the valve seat by a spring force. It can be observed from the figure that the fluid flow is not possible from the spring side but the fluid from opposite side can pass by lifting the ball against. However, there is some pressure drop across the valve due to restriction by the spring force. Therefore these valves are not suitable for the application of high flow rate. When the operating pressure increases the valve becomes more tightly seated in this design.

The advantages of the poppet valves include no leakage, long life and suitability with high pressure applications. These valves are commonly used in liquid or gel mini-pump dispenser spigots, spray devices, some rubber bulbs for pumping air, manual air pumps, and refillable dispensing syringes. Sometimes, the right angle check valve as shown in Figure 5.2.2 is used for the high flow rate applications. The pressure drop is comparatively less in right angle check valve.

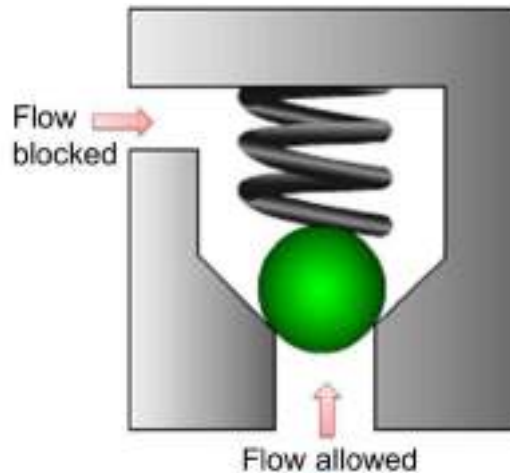


Figure 5.2.2 Right angle check valve

When the closing member is not a ball but a poppet energized by a spring is known as poppet valve. The typical poppet valve is shown in Figure 5.2.3. Some valves are meant for an application where free flow is required in one direction and restricted flow required in another direction. These types of valves are called as restriction check valve (see Figure 5.2.3). These valves are used when a direction sensitive flow rate is required. For example, the different actuator speeds are required in both the directions. The flow adjustment screw can be used to set the discharge (flow rate) in the restricted direction.

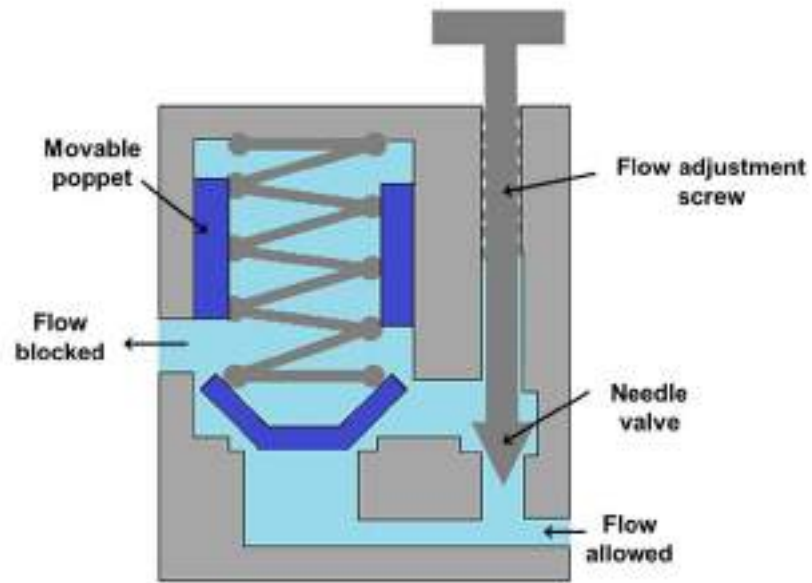


Figure 5.2.3 Restriction check valve

Another important type of check valve known as pilot operated check valve which is shown in figure 5.2.4. The function of the pilot operated check valve is similar to a normal check valve unless it gets an extra pressure signal through a pilot line. Pilot allows free flow in one direction and prevents the flow in another direction until the pilot pressure is applied. But when pilot pressure acts, the poppet opens and the flow is blocked from both the sides. These valves are used to stop the fluid suddenly.

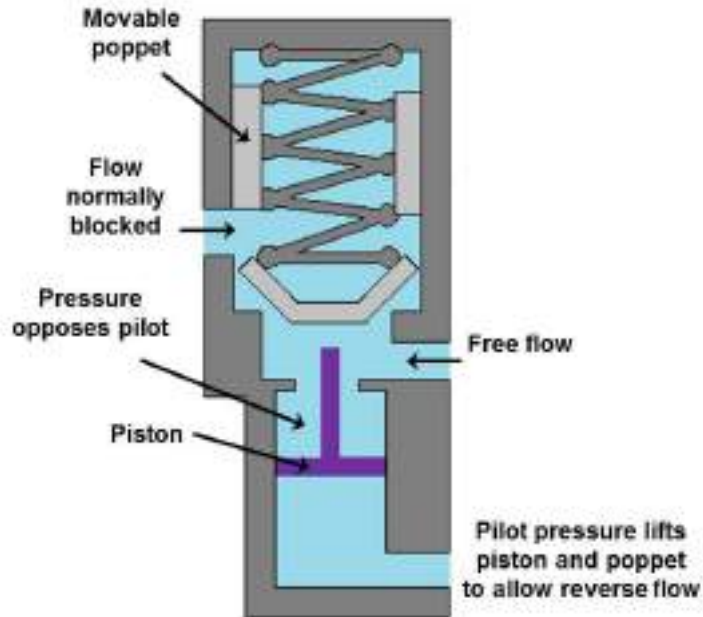


Figure 5.2.4 Pilot operated check valve



## 1.2 Number of ports

### 1.2.1 Two way valves

Two way valves have only two ports as shown in Figure 5.2.5 and Figure 5.2.6. These valves are also known as on-off valves because they allow the fluid flow only in direction. Normally, the valve is closed. These valves are available as normally open and normally closed function. These are the simplest type of spool valves. When actuating force is not applied to the right, the port P is not connected with port A as shown in figure 5.4.5. Therefore, the actuation does not take place. Similarly, Figure 5.4.6 shows the two-way spool valve in the open condition. Here, the pressure port P is connected with the actuator port A.

### 1.2.2 Three way valves

When a valve has one pressure port, one tank port and one actuating port as shown in Figures 5.2.7 and 5.2.8, it is known as three way valve. In this valve, the pressure port pressurizes one port and exhausts another one. As shown in figures, only one actuator port is opened at a time. In some cases a neutral position is also available when both the ports are blocked. Generally, these valves are used to operate single acting cylinders.

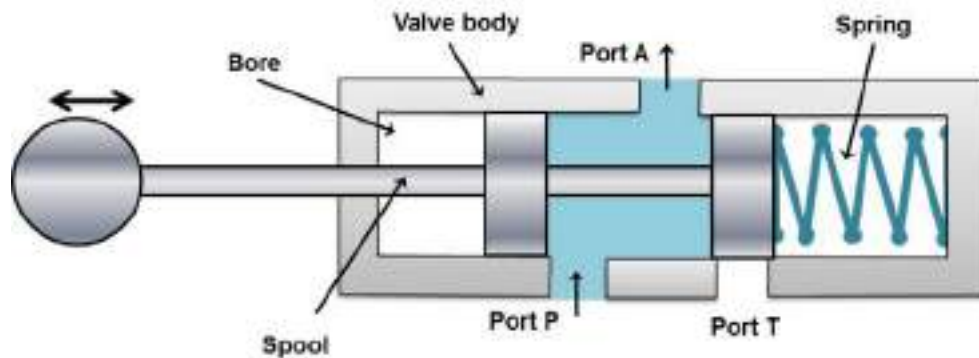


Figure 5.2.7 Three way valve: P to A connected and T is blocked

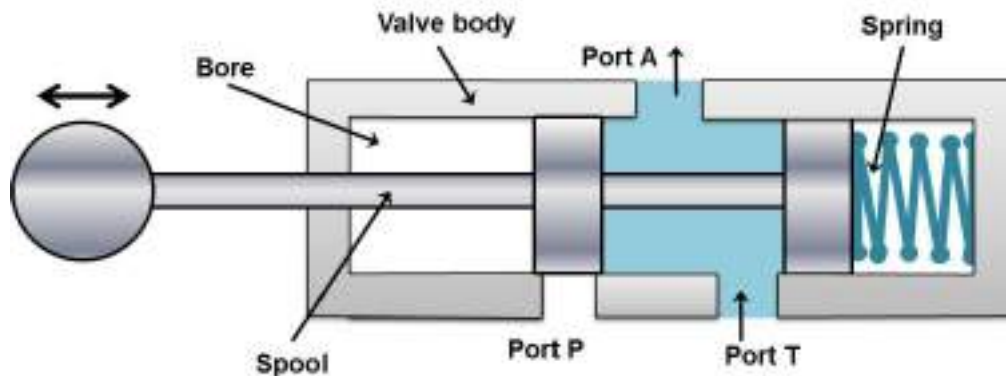


Figure 5.2.8 Three way valve in closed position

### 1.2.3 Four way valves

Figure 5.2.9 shows a four-way valve. It is generally used to operate the cylinders and fluid motors in both the directions. The four ways are: pump port P, tank port T, and two working ports A and B connected to the actuator. The primary function of a four way valve is to pressurize and exhaust two working ports A and B alternatively.

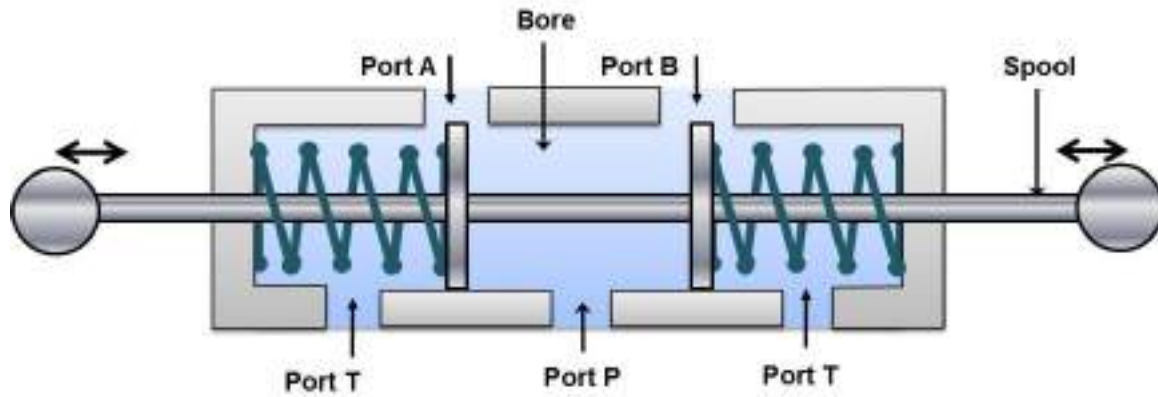


Figure 5.2.9 Three position four way valve in open center mode

## Control valves

### *1. Classification of control valve according to number/ways of switching position*

#### **1.1 Three position four way (3/4) valves**

Three position four way (3/4) valves are used in double-acting cylinders to perform advance, hold and return operation to the piston. Figures 5.2.10 and 5.2.11 show three position four way valves. These types of valves have three switching positions. They have a variety of possible flow path configurations but have identical flow path configuration. When the centered path is actuated, port A and B are connected with both the ports P and T respectively. In this case, valve is not active because all the ports are open to each other. The fluid flows to the tank at atmospheric pressure. In this position work cannot be done by any part of the system. This configuration helps to prevent heat buildup.

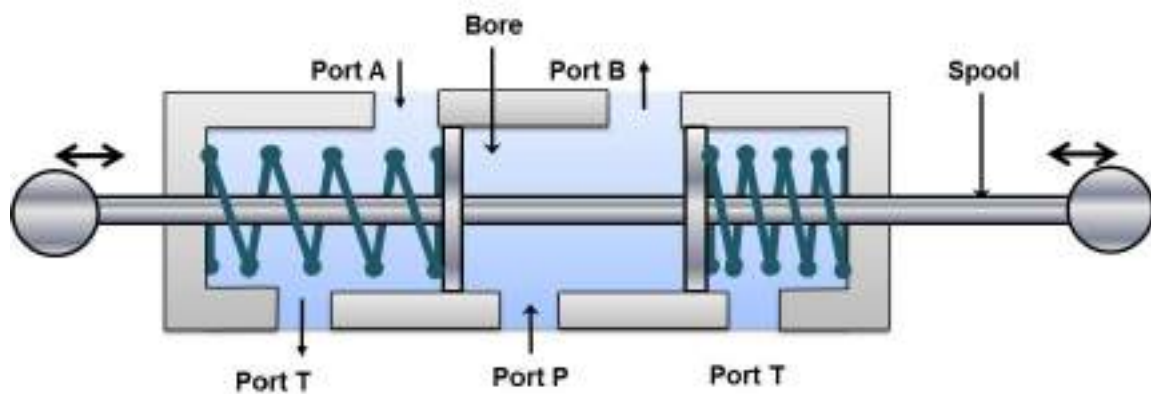


Figure 5.2.10 Three position four way valve: P to B and A to T



When left end (port B) is actuated, the port P is connected with ports B and T is connected with port A as shown in Figure 5.2.10. Similarly, when the right end is actuated the port P is connected to A and working port B is connected to port T as shown in Figure 5.2.11. The three position valves are used when the actuator is needed to stop or hold at some intermediate position. It can also be used when the multiple circuits or functions are accomplished from one hydraulic power source.

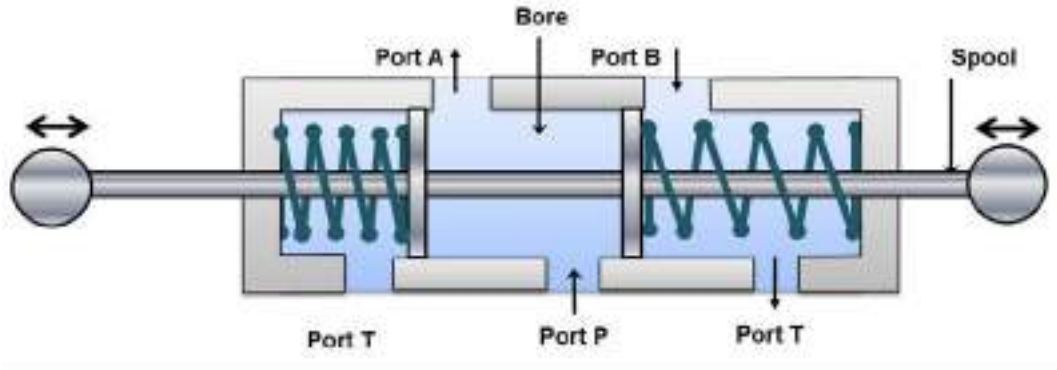


Figure 5.2.11 Three position four way valve: P to A and B to T

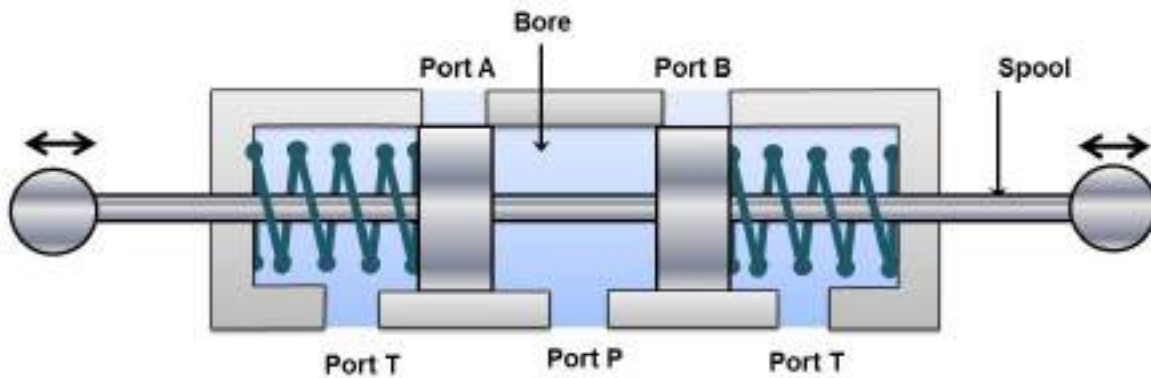


Figure 5.2.12 Three position four way valve: closed center

Figure 5.2.12 shows a three position four way valve in the closed center position. The working of the valve is similar to open center DCV. In closed center DCV all user ports (port A and port B) are closed. Therefore, these ports are hydraulically locked and the actuator cannot be moved by the external load. The pumped fluid flows through the relief valve. The pump works under the high pressure condition which not only wastes the pump power but also causes wear of the pump parts. The fluid temperature also rises due to heat generation by the pump energy transformation. The increase in fluid temperature may lead to the oxidation and viscosity drop of the fluid. The oxidation and viscosity drop reduces the pump life and leakage in the system.

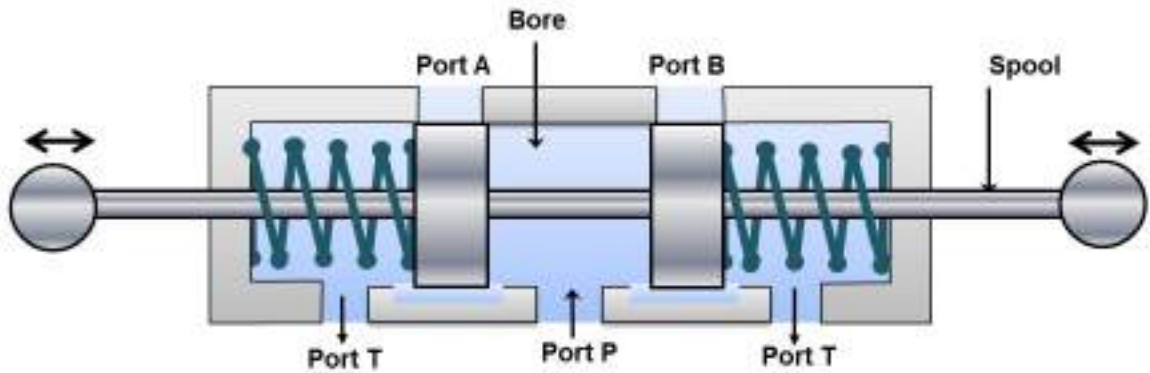


Figure 5.2.13 Tandem centered valve

Figure 5.2.13 shows a tandem center three position four way direction control valve. In this configuration, the working ports A and B are blocked and the pump port P is connected to the tank port T. Tandem center results in the locked actuator. However, pump to tank flow takes place at the atmospheric temperature. This kind of configuration can be used when the load is needed to hold. Disadvantages of high pressure pumping in case of closed center (shown in Figure 5.2.13) can be removed by using this configuration.

The regenerative center is another important type of common center configuration used in hydraulic circuits. Regenerative means the flow is generated from the system itself. Regenerative center is used when the actuator movement in one direction requires two different speeds. For example, the half-length of the stroke requires fast movement during no-load condition and remaining half-length requires slow motion during load conditions. The regenerative center saves the pump power.

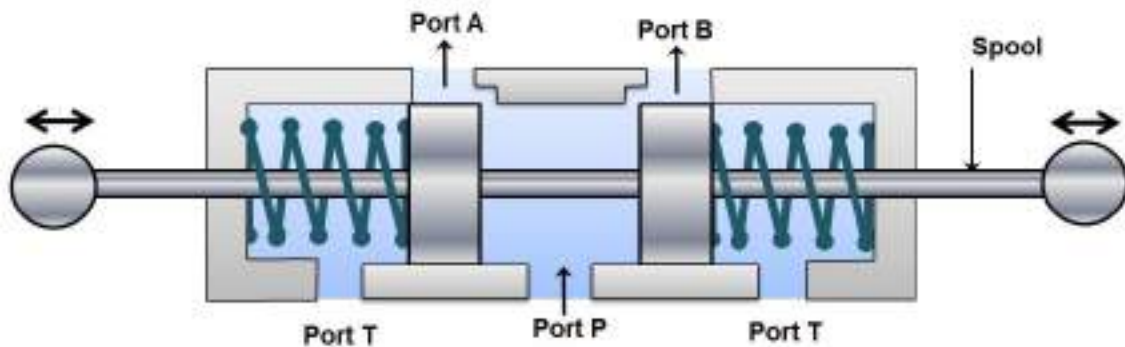


Figure 5.2.14 Regenerative Center

Figure 5.2.14 shows the regenerative configuration for the three position four way (3/4) DCV in its mid position. This configuration increases the piston speed. In the mid position pump Port P is connected to A and B, and tank port T is blocked.

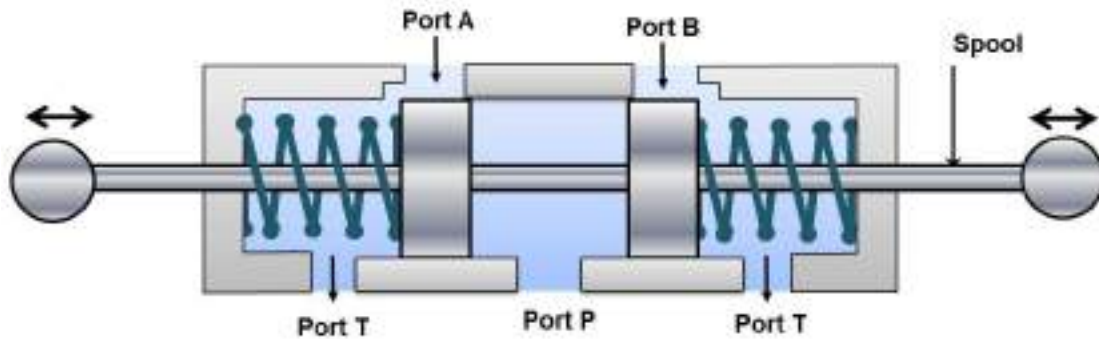


Figure 5.2.15 Floating Center

Figure 5.2.15 shows the floating center 3/4 DCV in its mid position. In this configuration, the pump port is blocked and both the working ports A and B are connected to the tank port T. Therefore, the working ports A and B can be moved freely which is reason they are called as floating center. The pumped fluid passes through the relief valve. Therefore, pump works in the high pressure condition. This configuration is used only in some special cases.

## 1.2 Two position four way (2/4) valves

The two position four way valves have only two switching positions and do not have any mid position. Therefore, they are also known as impulse valves. The typical connections of 2/4 valves is shown in Figures 5.2.16 and 5.2.17. These valves can be used to operate double acting cylinders. These are also used to reciprocate or hold an actuator. The operation is faster because the distance between ports of these valves is smaller. Hence, these valves are used on machines where fast reciprocation cycles are needed such as punching and stamping etc.

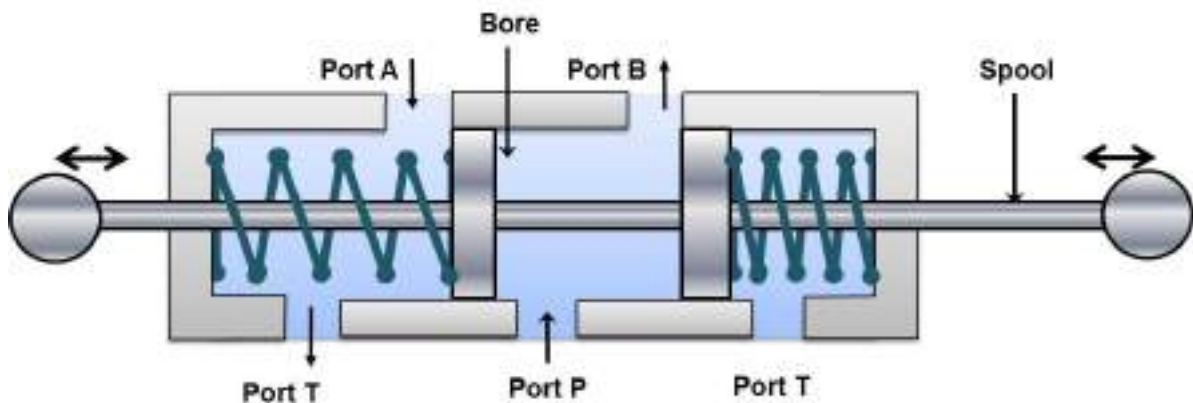


Figure 5.2.16 Two position four way DCV: P to B and A to T

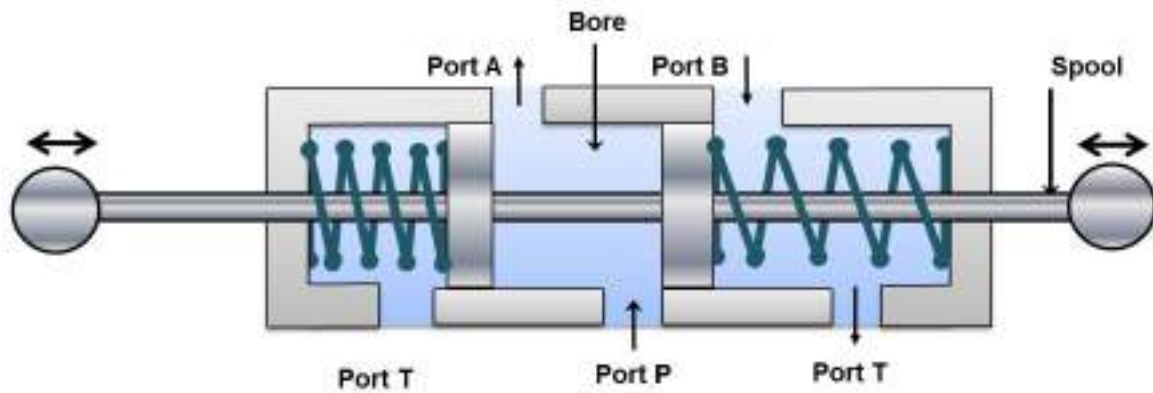


Figure 5.2.17 Two position four way DCV: P to A and B to T

## 2. Classification based on actuation

### mechanism 2.1 Manual actuation

In this type, the spool is operated manually. Manual actuators are hand lever, push button and pedals etc.

### 2.2 Mechanical actuation

The DCV spool can be operated by using mechanical elements such as roller and cam, roller and plunger and rack and pinion etc. In these arrangements, the spool end is of roller or a pinion gear type. The plunger or cam or rack gear is attached to the actuator. Thus, the mechanical elements gain some motion relative to the actuator (cylinder piston) which can be used for the actuation.

### 2.3 Solenoid actuation

The solenoid actuation is also known as electrical actuation. The schematic of solenoid actuation is shown in Figure 5.2.18. The energized solenoid coil creates a magnetic force which pulls the armature into the coil. This movement of armature controls the spool position. The main advantage of solenoid actuation is its less switching time.

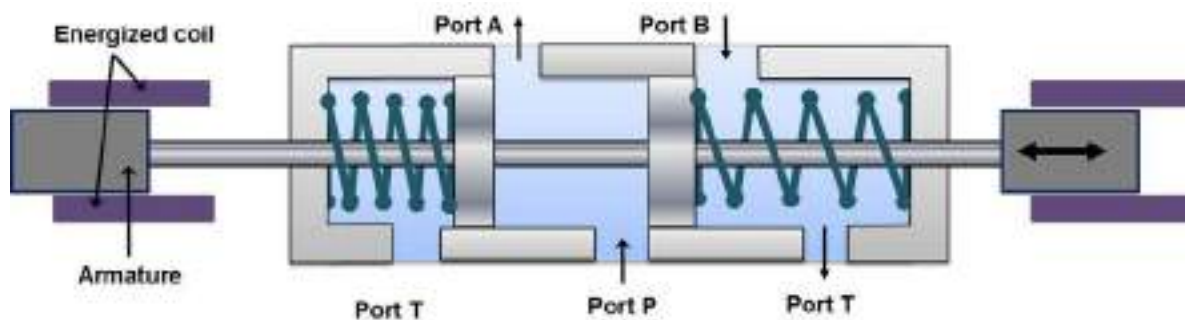


Figure 5.2.18 Working of solenoid to shift spool of valve

## 2.4 Hydraulic actuation

This type of actuation is usually known as pilot-actuated valve and a schematic is shown in Figure 5.2.19. In this type of actuation, the hydraulic pressure is directly applied on the spool. The pilot port is located on one end of the valve. Fluid entering from pilot port operates against the piston and forces the spool to move forward. The needle valve is used to control the speed of the actuation.

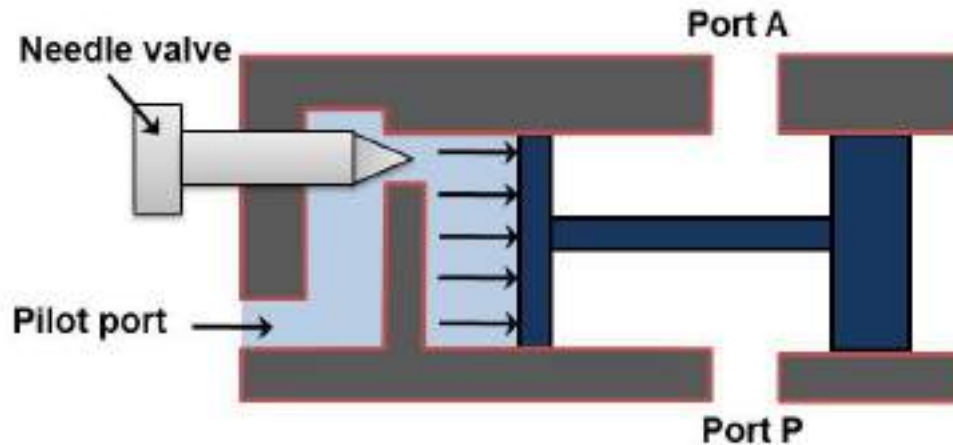


Figure 5.2.19 Pilot actuated DCV

## 2.5 Pneumatic actuation

DCV can also be operated by applying compressed air against a piston at either end of the valve spool. The construction of the system is similar to the hydraulic actuation as shown in Figure 5.2.20. The only difference would be the actuation medium. The actuation medium is the compressed air in pneumatic actuation system.

## 2.6 Indirect actuation of directional control valve

The direction control valve can be operated by manual, mechanical, solenoidal (electrical), hydraulic (pilot) and pneumatic actuations. The mode of actuation does not have any influence on the basic operation of the hydraulic circuits. Mostly, the direct actuation is restricted to use with smaller valves only because usually lot of force is not available. The availability of limited force is the greatest disadvantage of the direct actuation systems. In practice, the force required to shift the spool is quite higher. Therefore, the larger valves are often indirectly actuated in sequence. First, the smaller valve is actuated directly and the flow from the smaller valve is directed to either side of the larger valve. The control fluid can be supplied by the same circuit or by a separate circuit. The pilot valve pressure is usually supplied internally. These two valves are often incorporated as a single unit. These valves are also called as Electro-hydraulic operated DCV.

### 3. Flow Control Valves

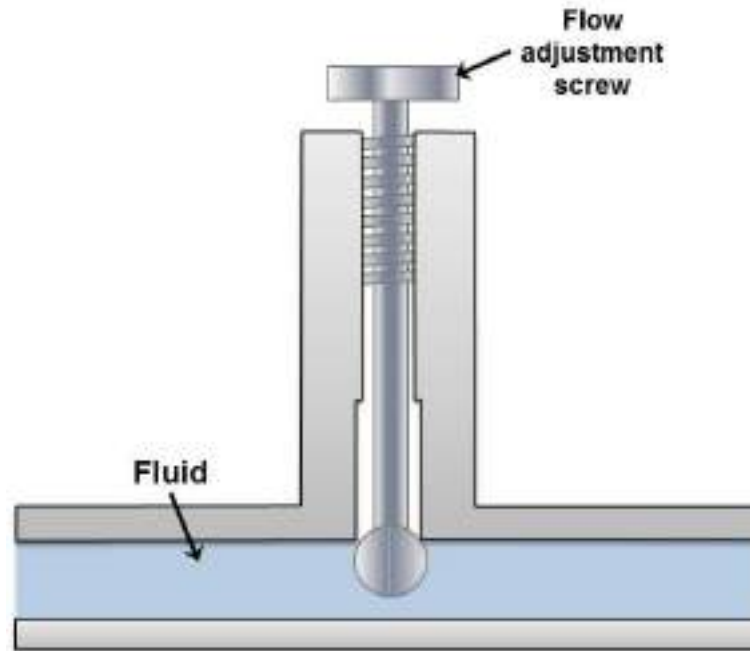


Figure 5.2.21 Flow Control Valve

In practice, the speed of actuator is very important in terms of the desired output and needs to be controlled. The speed of actuator can be controlled by regulating the fluid flow. A flow control valve can regulate the flow or pressure of the fluid. The fluid flow is controlled by varying area of the valve opening through which fluid passes. The fluid flow can be decreased by reducing the area of the valve opening and it can be increased by increasing the area of the valve opening. A very common example to the fluid flow control valve is the household tap. Figure 5.2.21 shows the schematic diagram of a flow control valve. The pressure adjustment screw varies the fluid flow area in the pipe to control the discharge rate.

The pressure drop across the valve may keep on fluctuating. In general, the hydraulic systems have a pressure compensating pump. The inlet pressure remains almost constant but the outlet pressure keeps on fluctuating depending on the external load. It creates fluctuating pressure drop. Thus, the ordinary flow control valve will not be able to maintain a constant fluid flow. A pressure compensated flow control valve maintains the constant flow throughout the movement of a spool, which shifts its position depending on the pressure. Flow control valves can also be affected by temperature changes. It is because the viscosity of the fluid changes with temperature. Therefore, the advanced flow control valves often have the temperature compensation. The temperature compensation is achieved by the thermal expansion of a rod, which compensates for the increased coefficient of discharge due to decreasing viscosity with temperature.

## 4. Types of Flow Control Valves

The flow control valves work on applying a variable restriction in the flow path. Based on the construction; there are mainly four types viz. plug valve, butterfly valve, ball valve and balanced valve.

### 4.1 Plug or glove valve

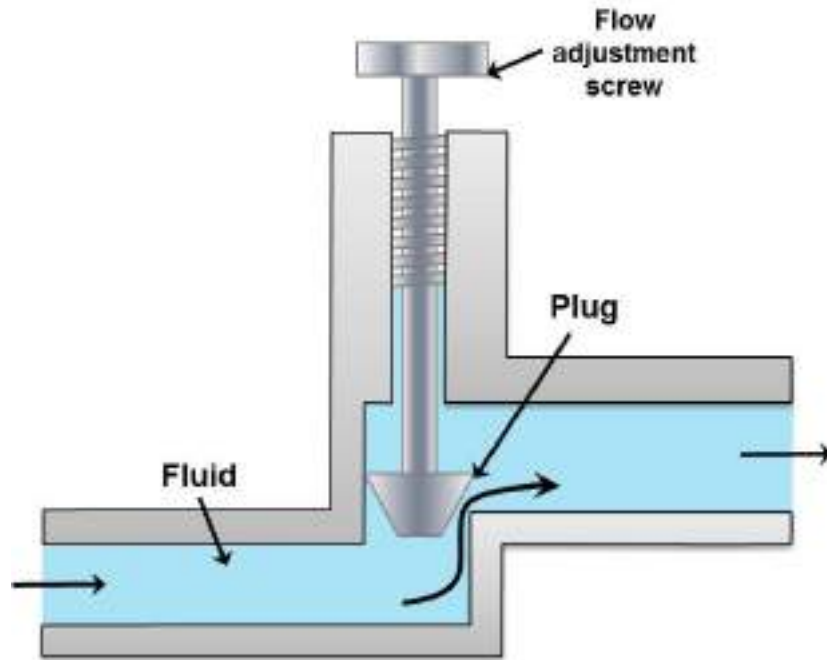


Figure 5.2.22 Plug or glove valve

The plug valve is quite commonly used valve. It is also termed as glove valve. Schematic of plug or glove valve is shown in Figure 5.2.22. This valve has a plug which can be adjusted in vertical direction by setting flow adjustment screw. The adjustment of plug alters the orifice size between plug and valve seat. Thus the adjustment of plug controls the fluid flow in the pipeline. The characteristics of these valves can be accurately predetermined by machining the taper of the plug. The typical example of plug valve is stopcock that is used in laboratory glassware. The valve body is made of glass or teflon. The plug can be made of plastic or glass. Special glass stopcocks are made for vacuum applications. Stopcock grease is used in high vacuum applications to make the stopcock air-tight.

## 4.2 Butterfly valve

A butterfly valve is shown in Figure 5.2.23. It consists of a disc which can rotate inside the pipe. The angle of disc determines the restriction. Butterfly valve can be made to any size and is widely used to control the flow of gas. These valves have many types which have for different pressure ranges and applications. The resilient butterfly valve uses the flexibility of rubber and has the lowest pressure rating. The high performance butterfly valves have a slight offset in the way the disc is positioned. It increases its sealing ability and decreases the wear. For high-pressure systems, the triple offset butterfly valve is suitable which makes use of a metal seat and is therefore able to withstand high pressure. It has higher risk of leakage on the shut-off position and suffer from the dynamic torque effect. Butterfly valves are favored because of their lower cost and lighter weight. The disc is always present in the flow therefore a pressure drop is induced regardless of the valve position.

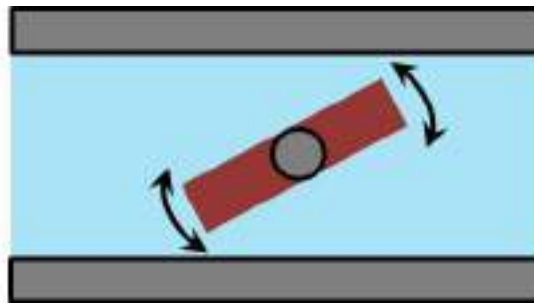


Figure 5.2.23 Butterfly valve

## 4.3 Ball Valve

The ball valve is shown in Figure 5.2.24. This type of flow control valve uses a ball rotated inside a machined seat. The ball has a through hole as shown in Figure 5.2.24. It has very less leakage in its shut-off condition. These valves are durable and usually work perfectly for many years. They are excellent choice for shutoff applications. They do not offer fine control which may be necessary in throttling applications. These valves are widely used in industries because of their versatility, high supporting pressures (up to 1000 bar) and temperatures (up to 250°C). They are easy to repair and operate.

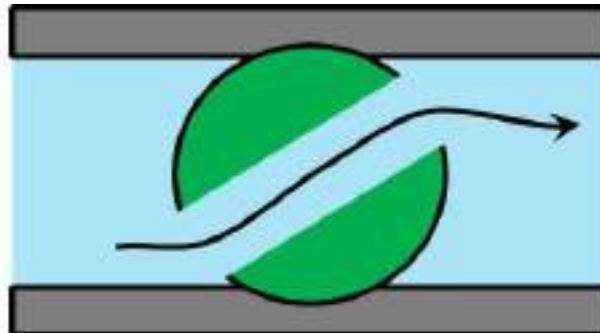


Figure 5.2.24 Ball valve



#### 4.4 Balanced valve

Schematic of a balanced valve is shown in figure 5.2.25. It comprises of two plugs and two seats. The opposite flow gives little dynamic reaction onto the actuator shaft. It results in the negligible dynamic torque effect. However, the leakage is more in these kind of valves because the manufacturing tolerance can cause one plug to seat before the other. The pressure-balanced valves are used in the houses. They provide water at nearly constant temperature to a shower or bathtub despite of pressure fluctuations in either the hot or cold supply lines.

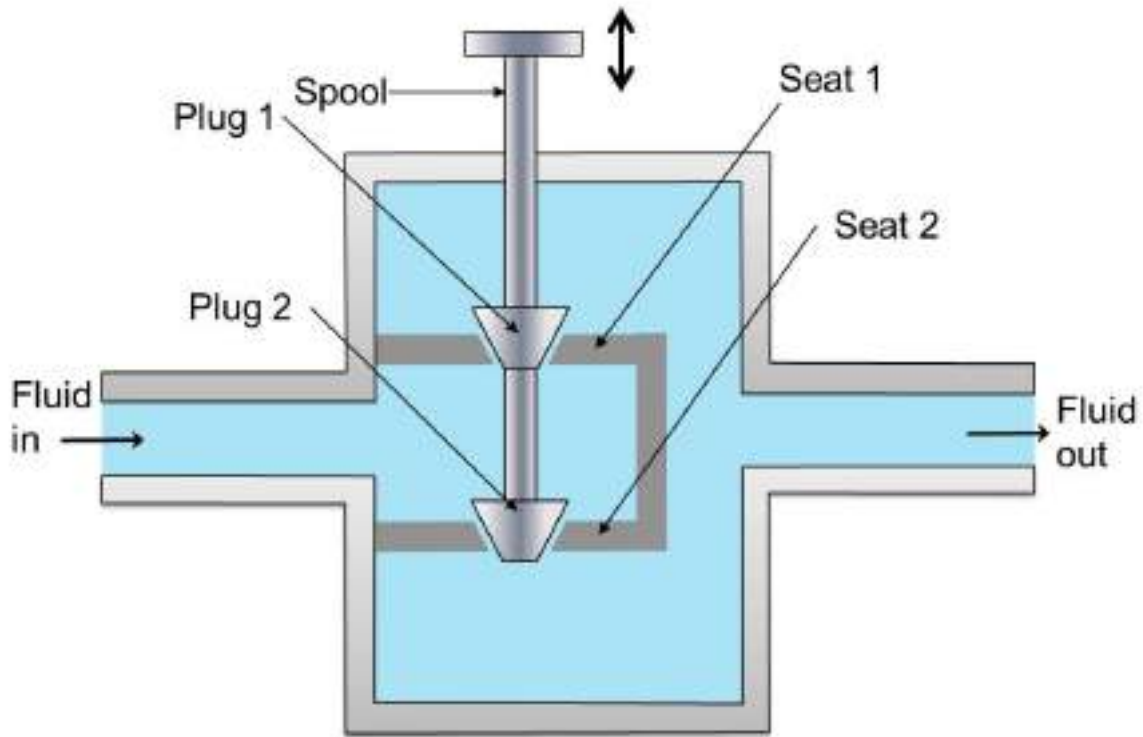


Figure 5.2.25 Balanced valve

## Pressure relief valves

The pressure relief valves are used to protect the hydraulic components from excessive pressure. This is one of the most important components of a hydraulic system and is essentially required for safe operation of the system. Its primary function is to limit the system pressure within a specified range. It is normally a closed type and it opens when the pressure exceeds a specified maximum value by diverting pump flow back to the tank. The simplest type valve contains a poppet held in a seat against the spring force as shown in Figure 5.6.1. The fluid enters from the opposite side of the poppet. When the system pressure exceeds the preset value, the poppet lifts and the fluid is escaped through the orifice to the storage tank directly. It reduces the system pressure and as the pressure reduces to the set limit again the valve closes. This valve does not provide a flat cut-off pressure limit with flow rate because the spring must be deflected more when the flow rate is higher. Various types of pressure control valves are discussed in the following sections:

### *1. Direct type of relief valve*

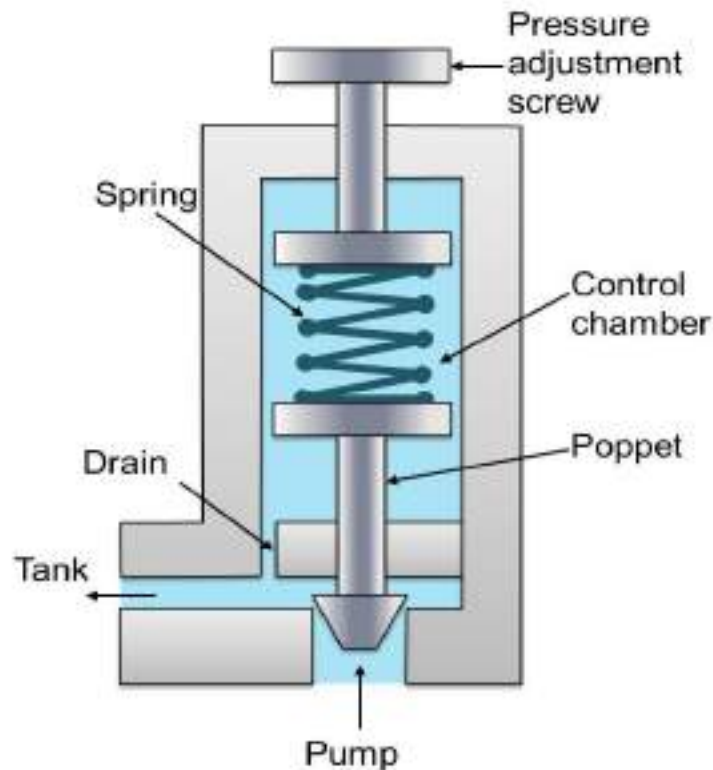


Figure 5.2.26 Pressure Relief Valve

Schematic of direct pressure relief valve is shown in figure 5.2.26. This type of valves has two ports; one of which is connected to the pump and another is connected to the tank. It consists of a spring chamber where poppet is placed with a spring force. Generally, the spring is adjustable to set the maximum pressure limit of the system. The poppet is held in position by combined effect of spring force and dead weight of spool. As the pressure exceeds this combined force, the poppet raises and excess fluid bypassed to the reservoir (tank). The poppet again reseats as the pressure drops below the pre-set value. A drain is also provided in the control chamber. It sends the fluid collected due to small leakage to the tank and thereby prevents the failure of the valve.

## 2. Unloading Valve

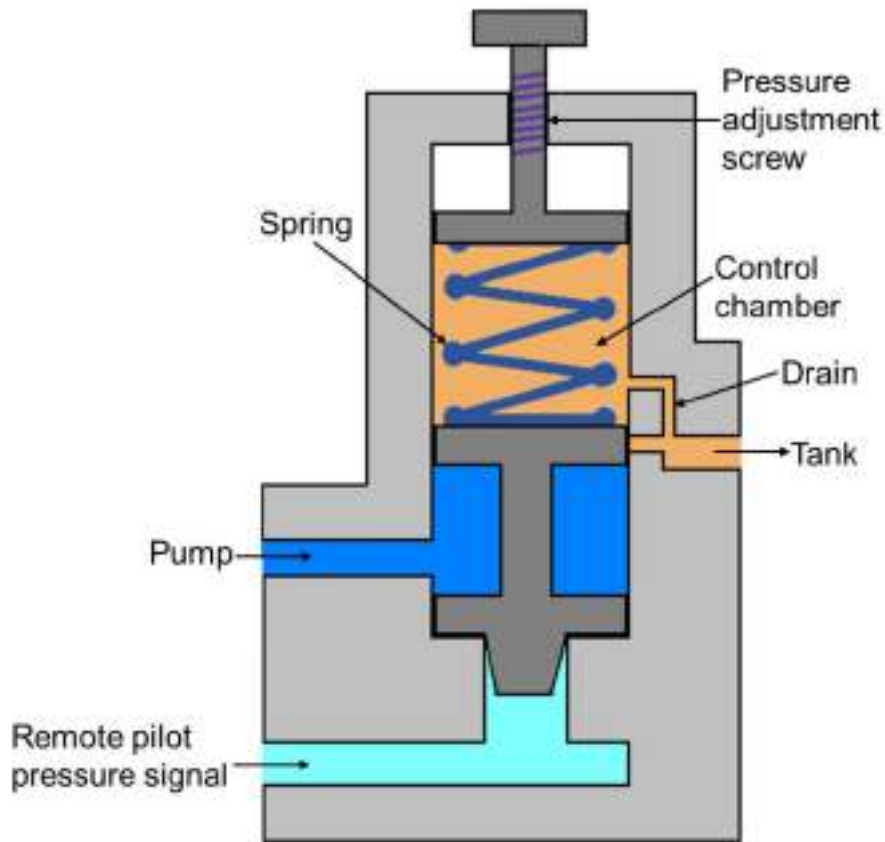


Figure 5.2.27 Unloading Valve

The construction of unloading valve is shown in Figure 5.2.27. This valve consists of a control chamber with an adjustable spring which pushes the spool down. The valve has two ports: one is connected to the tank and another is connected to the pump. The valve is operated by movement of the spool. Normally, the valve is closed and the tank port is also closed. These valves are used to permit a pump to operate at the minimum load. It works on the same principle as direct control valve that the pump delivery is diverted to the tank when sufficient pilot pressure is applied to move the spool. The pilot pressure maintains a static pressure to hold the valve opened. The pilot pressure holds the valve until the pump delivery is needed in the system. As the pressure is needed in the

hydraulic circuit; the pilot pressure is relaxed and the spool moves down due to the self-weight and the spring force. Now, the flow is diverted to the hydraulic circuit. The drain is provided to remove the leaked oil collected in the control chamber to prevent the valve failure. The unloading valve reduces the heat buildup due to fluid discharge at a preset pressure value.

### 3. *Sequence valve*

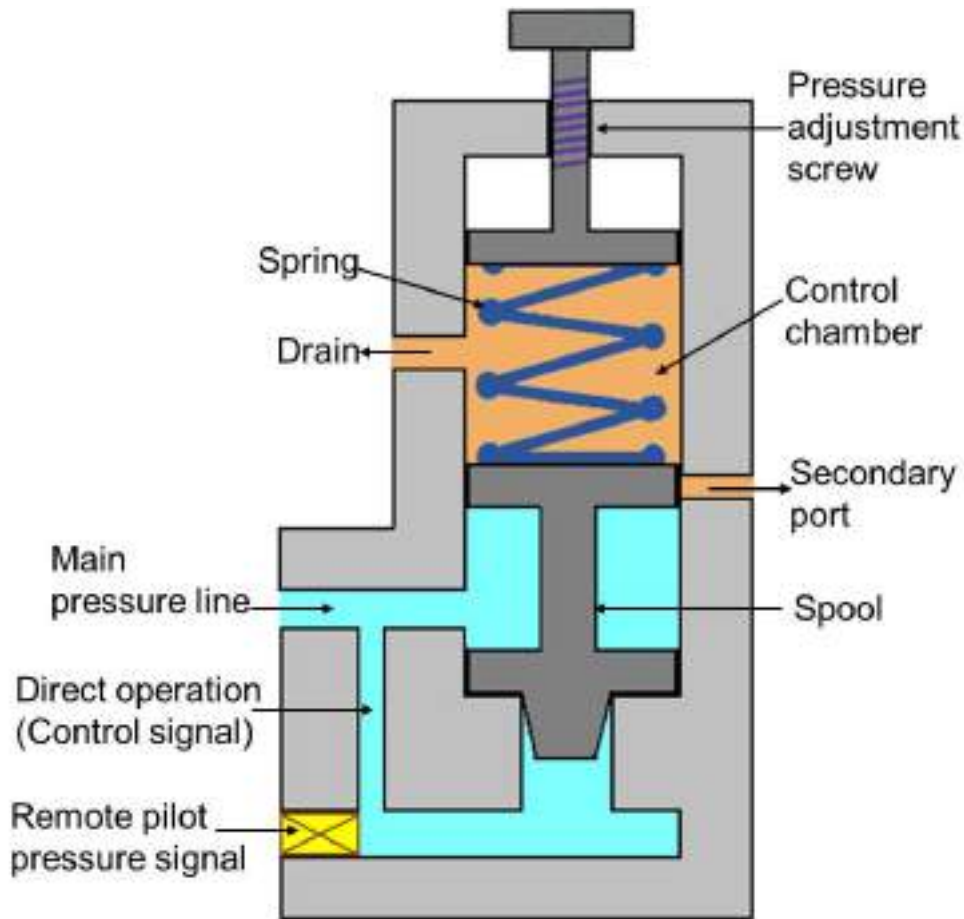


Figure 5.2.28 Sequence valve

The primary function of this type of valve is to divert flow in a predetermined sequence. It is used to operate the cycle of a machine automatically. A sequence valve may be of direct-pilot or remote-pilot operated type.

Schematic of the sequence valve is shown in Figure 5.2.28. Its construction is similar to the direct relief valve. It consists of the two ports; one main port connecting the main pressure line and another port (secondary port) is connected to the secondary circuit. The secondary port is usually closed by the spool. The pressure on the spool works against the spring force. When the pressure exceeds the preset value of the spring; the spool lifts and the fluid flows from the primary port to the secondary port. For remote

operation; the passage used for the direct operation is closed and a separate pressure source for the spool operation is provided in the remote operation mode.

#### 4. Counterbalance Valve

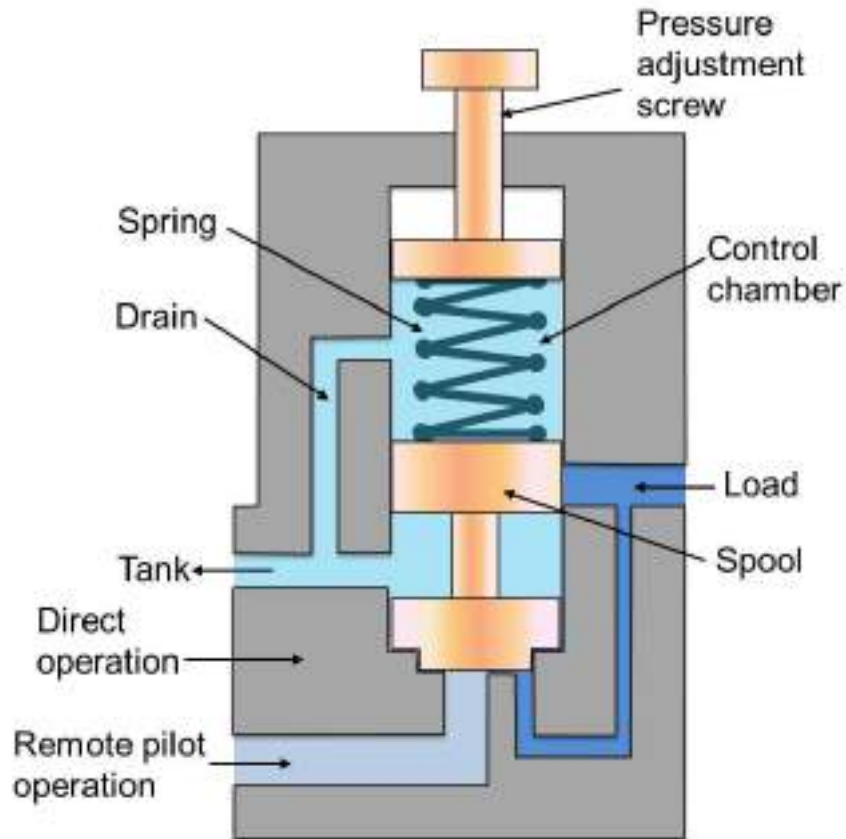


Figure 5.2.29 Counter Balance Valve

The schematic of counterbalance valve is shown in Figure 5.2.29. It is used to maintain the back pressure and to prevent a load from falling. The counterbalance valves can be used as breaking valves for decelerating heavy loads. These valves are used in vertical presses, lift trucks, loaders and other machine tools where position or hold suspended loads are important. Counterbalance valves work on the principle that the fluid is trapped under pressure until pilot pressure overcomes the pre-set value of spring force. Fluid is then allowed to escape, letting the load to descend under control. This valve is normally closed until it is acted upon by a remote pilot pressure source. Therefore, a lower spring force is sufficient. It leads to the valve operation at the lower pilot pressure and hence the power consumption reduces, pump life increases and the fluid temperature decreases.

## 5. Pressure Reducing Valve

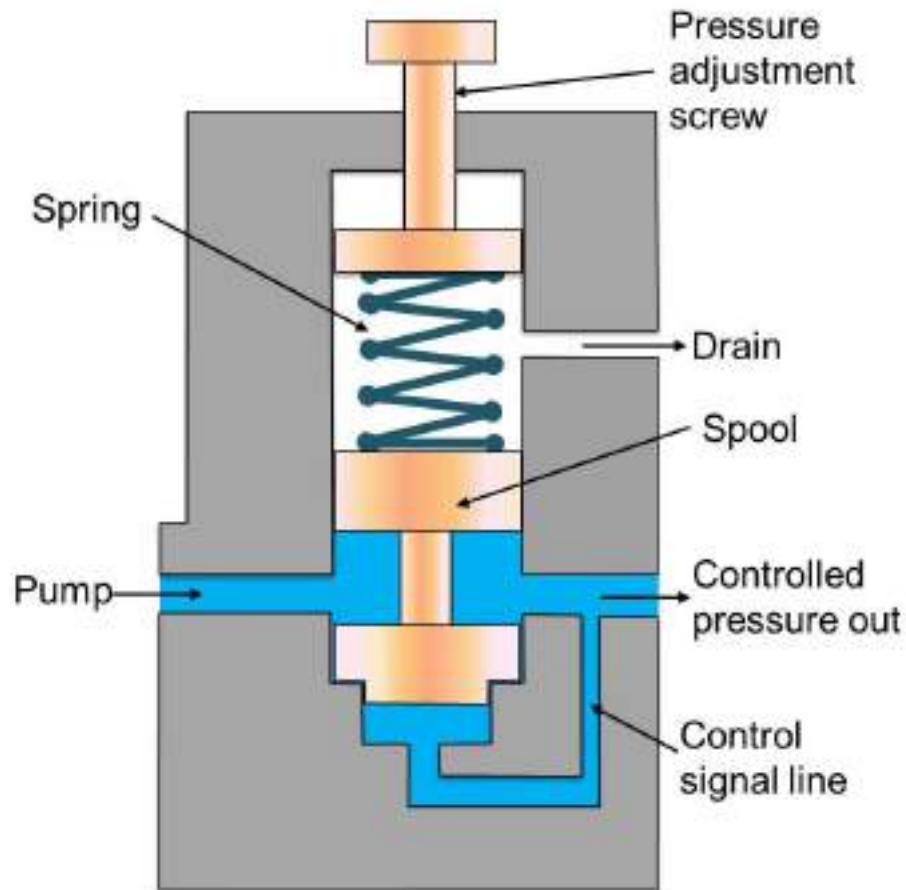


Figure 5.2.30 Pressure Reducing Valve

Sometimes a part of the system may need a lower pressure. This can be made possible by using pressure reducing valve as shown in Figure 5.2.30. These valves are used to limit the outlet pressure. Generally, they are used for the operation of branch circuits where the pressure may vary from the main hydraulic pressure lines. These are open type valve and have a spring chamber with an adjustable spring, a movable spool as shown in figure. A drain is provided to return the leaked fluid in the spring (control) chamber. A free flow passage is provided from inlet port to the outlet port until a signal from the outlet port tends to throttle the passage through the valve. The pilot pressure opposes the spring force and when both are balanced, the downstream is controlled at the pressure setting. When the pressure in the reduced pressure line exceeds the valve setting, the spool moves to reduce the flow passage area by compressing the spring. It can be seen from the figure that if the spring force is more, the valve opens wider and if the controlled pressure has greater force, the valves moves towards the spring and throttles the flow.

### 5.3 Cylinders and rotary actuators

Actuators are output devices which convert energy from pressurized hydraulic oil or compressed air into the required type of action or motion. In general, hydraulic or pneumatic systems are used for gripping and/or moving operations in industry. These operations are carried out by using actuators.

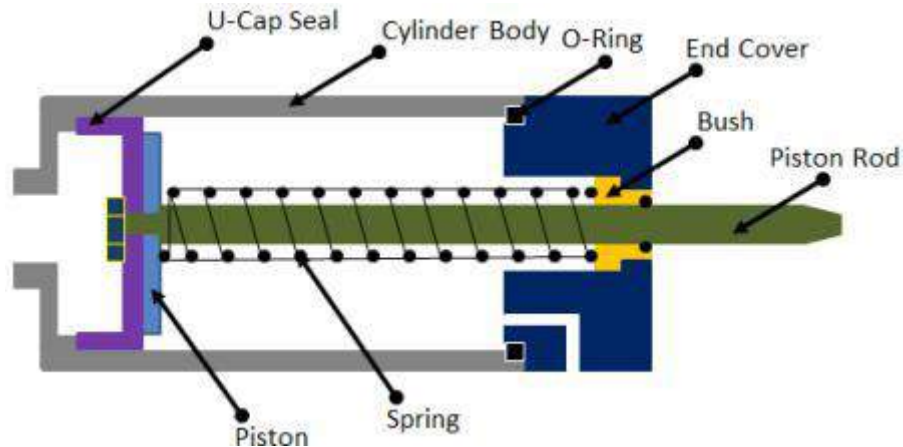
Actuators can be classified into three types.

- **Linear actuators:** These devices convert hydraulic/pneumatic energy into linear motion.

- Rotary actuators: These devices convert hydraulic/pneumatic energy into rotary motion.
- Actuators to operate flow control valves: these are used to control the flow and pressure of fluids such as gases, steam or liquid.

The construction of hydraulic and pneumatic linear actuators is similar. However they differ at their operating pressure ranges. Typical pressure of hydraulic cylinders is about 100 bar and of pneumatic system is around 10 bar.

### ***1. Single acting cylinder***



**Fig. 5.3.1 Single acting cylinder**

These cylinders produce work in one direction of motion hence they are named as single acting cylinders. Figure 5.3.1 shows the construction of a single acting cylinder. The compressed air pushes the piston located in the cylindrical barrel causing the desired motion. The return stroke takes place by the action of a spring. Generally the spring is provided on the rod side of the cylinder.

## 2. Double acting cylinder

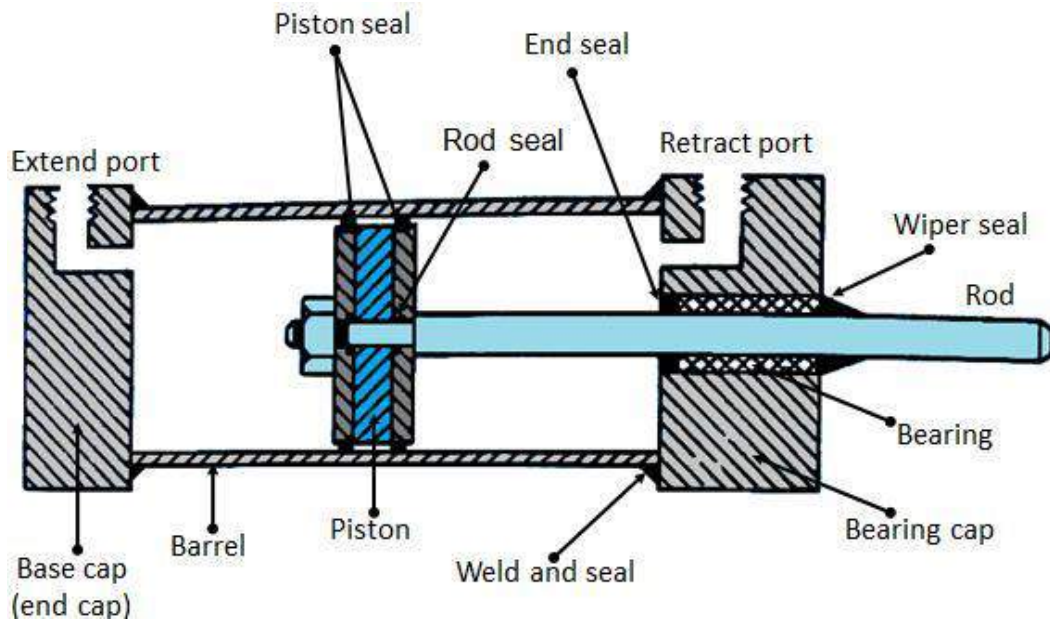


Fig. 5.3.2 Double acting cylinder

The main parts of a hydraulic double acting cylinder are: piston, piston rod, cylinder tube, and end caps. These are shown in Figure 5.3.2. The piston rod is connected to piston head and the other end extends out of the cylinder. The piston divides the cylinder into two chambers namely the rod end side and piston end side. The seals prevent the leakage of oil between these two chambers. The cylindrical tube is fitted with end caps. The pressurized oil, air enters the cylinder chamber through the ports provided. In the rod end cover plate, a wiper seal is provided to prevent the leakage of oil and entry of the contaminants into the cylinder. The combination of wiper seal, bearing and sealing ring is called as cartridge assembly. The end caps may be attached to the tube by threaded connection, welded connection or tie rod connection. The piston seal prevents metal to metal contact and wear of piston head and the tube. These seals are replaceable. End cushioning is also provided to prevent the impact with end caps.



### 3. Cylinder end cushions

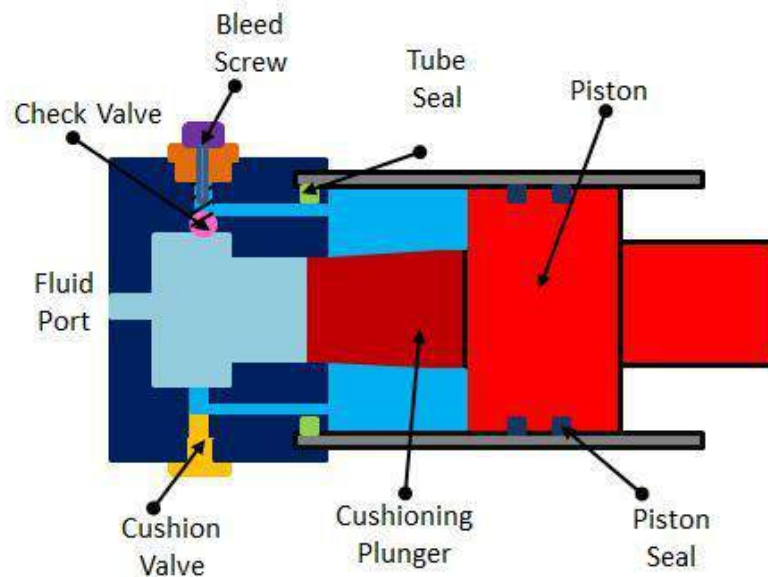


Fig. 5.3.3 Cylinder end cushioning

Double acting cylinders generally contain cylinder cushions at the end of the cylinder to slow down the movement of the piston near the end of the stroke. Figure 5.3.3 shows the construction of actuating cylinder with end cushions. Cushioning arrangement avoids the damage due to the impact occurred when a fast moving piston is stopped by the end caps. Deceleration of the piston starts when the tapered plunger enters the opening in the cap and closes the main fluid exit. This restricts the exhaust flow from the barrel to the port. This throttling causes the initial speed reduction. During the last portion of the stroke the oil has to exhaust through an adjustable opening since main fluid exit closes. Thus the remaining fluid exits through the cushioning valve. Amount of cushioning can be adjusted by means of cushion screw. A check valve is provided to achieve fast break away from the end position during retraction motion. A bleed screw is built into the check valve to remove the air bubbles present in a hydraulic type system.

#### 4. Gear motor: a rotary actuator

Rotary actuators convert energy of pressurized fluid into rotary motion. Rotary actuators are similar to electric motors but are run on hydraulic or pneumatic power.

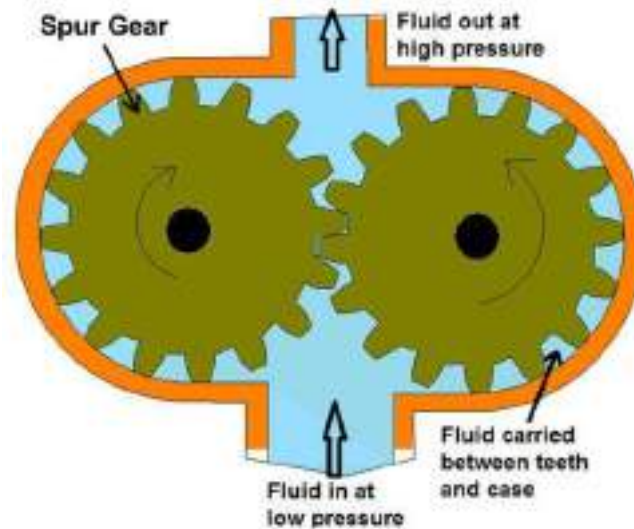


Fig. 5.3.4 Gear motor

It consists of two inter meshing gears inside a housing with one gear attached to the drive shaft. Figure 5.3.4 shows a schematic diagram of Gear motor. The air enters from the inlet, causes the rotation of the meshing gear due to difference in the pressure and produces the torque. The air exits from the exhaust port. Gear motors tend to leak at low speed, hence are generally used for medium speed applications.

#### 5. Vane motor: a rotary actuator

A rotary vane motor consists of a rotor with sliding vanes in the slots provided on the rotor (Fig. 5.3.5). The rotor is placed eccentrically with the housing. Air enters from the inlet port, rotates the rotor and thus torque is produced. Air is then released from the exhaust port (outlet).

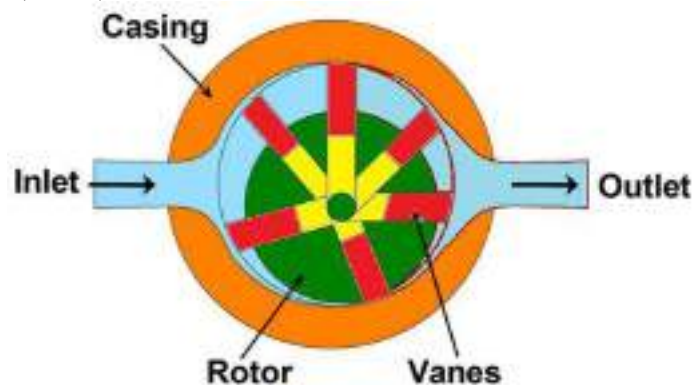


Fig. 5.3.5 Vane motor

## 6. Limited rotation actuators

It consists of a single rotating vane connected to output shaft as shown in Figure 5.3.6. It is used for double acting operation and has a maximum angle of rotation of about  $270^\circ$ . These are generally used to actuate dampers in robotics and material handling applications. Other type of limited rotation actuator is a rack and pinion type actuator.

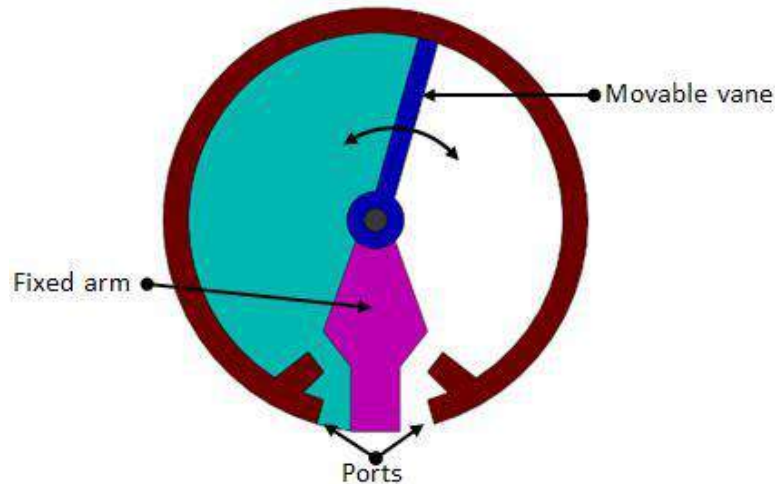


Fig. 5.3.6 Semi rotary vane type actuator

## 5.4 Principle & construction details Symbols of hydraulic elements, components of hydraulic system, and functions of various units of hydraulic system

The controlled movement of parts or a controlled application of force is a common requirement in the industries. These operations are performed mainly by using electrical machines or diesel, petrol and steam engines as a prime mover. These prime movers can provide various movements to the objects by using some mechanical attachments like screw jack, lever, rack and pinions etc. However, these are not the only prime movers. The enclosed fluids (liquids and gases) can also be used as prime movers to provide controlled motion and force to the objects or substances. The specially designed enclosed fluid systems can provide both linear as well as rotary motion. The high magnitude controlled force can also be applied by using these systems. This kind of enclosed fluid based systems using pressurized incompressible liquids as transmission media are called as hydraulic systems. The hydraulic system works on the principle of Pascal's law which says that the pressure in an enclosed fluid is uniform in all the directions. The Pascal's law is illustrated in figure 5.4.1. The force given by fluid is given by the multiplication of pressure and area of cross section. As the pressure is same in all the direction, the smaller piston feels a smaller force and a large piston feels a large force. Therefore, a large force can be generated with smaller force input by using hydraulic systems.

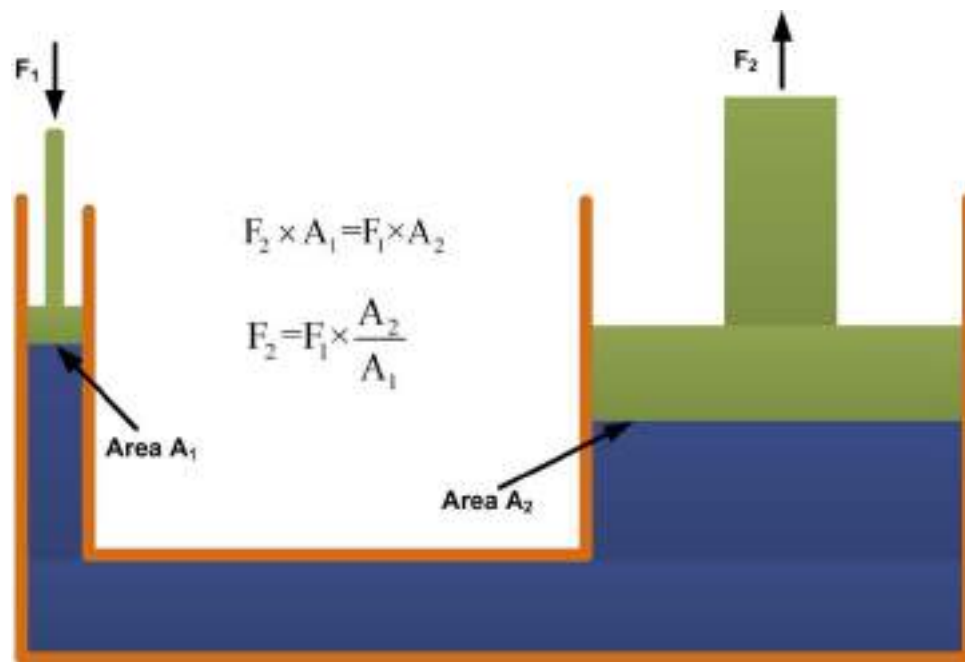


Figure 5.4.1 Principle of hydraulic system

The hydraulic systems consists a number of parts for its proper functioning. These include storage tank, filter, hydraulic pump, pressure regulator, control valve, hydraulic cylinder, piston and leak proof fluid flow pipelines. The schematic of a simple hydraulic system is shown in figure 5.4.2. It consists of:

- a movable piston connected to the output shaft in an enclosed cylinder
- storage tank
- filter
- electric pump
- pressure regulator
- control valve
- leak proof closed loop piping.

The output shaft transfers the motion or force however all other parts help to control the system. The storage/fluid tank is a reservoir for the liquid used as a transmission media. The liquid used is generally high density incompressible oil. It is filtered to remove dust or any other unwanted particles and then pumped by the hydraulic pump. The capacity of pump depends on the hydraulic system design. These pumps generally deliver constant volume in each revolution of the pump shaft. Therefore, the fluid pressure can increase indefinitely at the dead end of the piston until the system fails. The pressure regulator is used to avoid such circumstances which redirect the excess fluid back to the storage tank. The movement of piston is controlled by changing liquid flow from port A and port B. The cylinder movement is controlled by using control valve which directs the fluid flow. The fluid pressure line is connected to the port B to raise the piston and it is connected to port A to lower down the piston. The valve can also stop the fluid flow in any of the port. The leak proof piping is also important due to safety, environmental hazards and economical aspects. Some accessories such as flow control system, travel limit control, electric motor starter and overload protection may also be used in the hydraulic systems which are not shown in figure 5.4.2.

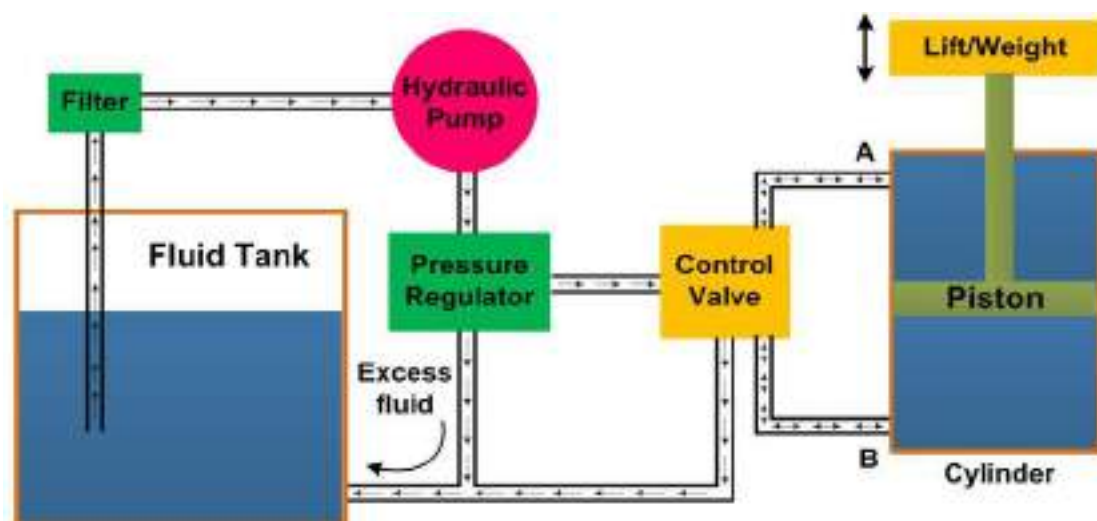


Figure 5.4.2 Schematic of hydraulic system

### ***Applications of hydraulic systems***

The hydraulic systems are mainly used for precise control of larger forces. The main applications of hydraulic system can be classified in five categories:

**Industrial:** Plastic processing machineries, steel making and primary metal extraction applications, automated production lines, machine tool industries, paper industries, loaders, crushes, textile machineries, R & D equipment and robotic systems etc.

**Mobile hydraulics:** Tractors, irrigation system, earthmoving equipment, material handling equipment, commercial vehicles, tunnel boring equipment, rail equipment, building and construction machineries and drilling rigs etc.

**Automobiles:** It is used in the systems like breaks, shock absorbers, steering system, wind shield, lift and cleaning etc.

**Marine applications:** It mostly covers ocean going vessels, fishing boats and navel equipment.

**Aerospace equipment:** There are equipment and systems used for rudder control, landing gear, breaks, flight control and transmission etc. which are used in airplanes, rockets and spaceships.

### ***3. Hydraulic Pump***

The combined pumping and driving motor unit is known as hydraulic pump. The hydraulic pump takes hydraulic fluid (mostly some oil) from the storage tank and delivers it to the rest of the hydraulic circuit. In general, the speed of pump is constant and the pump delivers an equal volume of oil in each revolution. The amount and direction of fluid flow is controlled by some external mechanisms. In some cases, the hydraulic pump itself is operated by a servo controlled motor but it makes the system complex. The hydraulic pumps are characterized by its flow rate capacity, power consumption, drive speed, pressure delivered at the outlet and efficiency of the pump. The pumps are not 100% efficient. The efficiency of a pump can be specified by two ways. One is the volumetric efficiency which is the ratio of actual volume of fluid delivered to the maximum theoretical volume possible. Second is power efficiency which is the ratio of output hydraulic power to the input mechanical/electrical power. The typical efficiency of pumps varies from 90-98%.

The hydraulic pumps can be of two types:

- centrifugal pump
- reciprocating pump

Centrifugal pump uses rotational kinetic energy to deliver the fluid. The rotational energy typically comes from an engine or electric motor. The fluid enters the pump impeller along or near to the rotating axis, accelerates in the propeller and flung out to the periphery by centrifugal force as shown in figure 5.4.3. In centrifugal pump the delivery is not constant and varies according to the outlet pressure. These pumps are not suitable for high pressure applications and are generally used for low-pressure and high-volume flow applications. The maximum pressure capacity is limited to 20-30 bars and the specific speed ranges from 500 to 10000. Most of the centrifugal pumps are not self-priming and the pump casing needs to be filled with liquid before the pump is started.

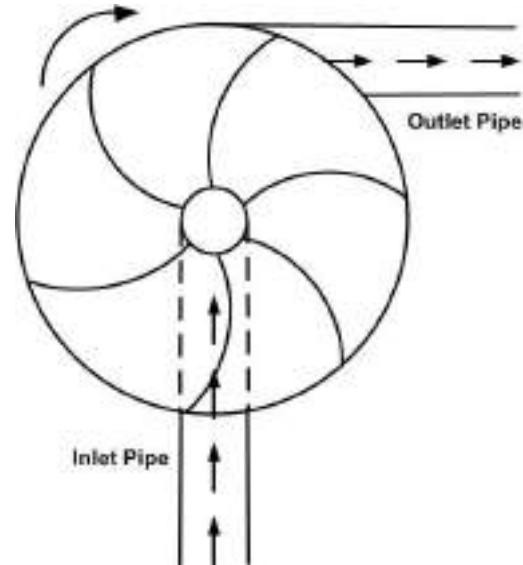
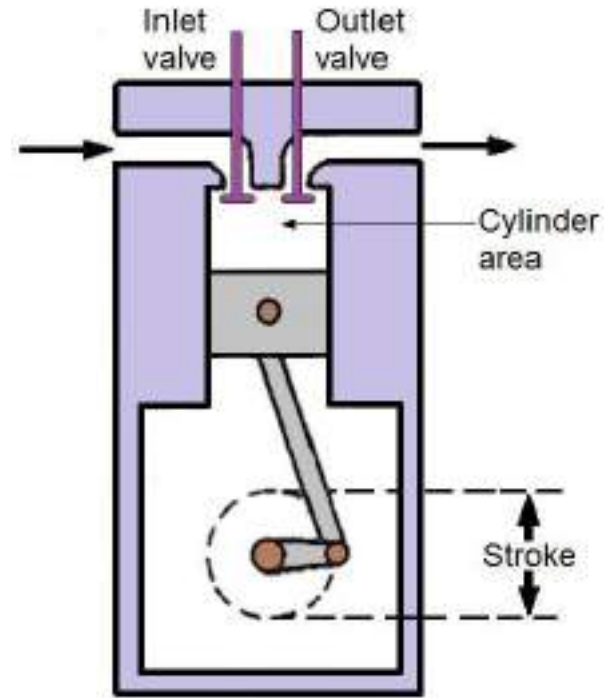


Figure 5.4.3 Centrifugal pump

The reciprocating pump is a positive plunger pump. It is also known as positive displacement pump or piston pump. It is often used where relatively small quantity is to be handled and the delivery pressure is quite large. The construction of these pumps is similar to the four stroke engine as shown in figure 5.4.4. The crank is driven by some external rotating motor. The piston of pump reciprocates due to crank rotation. The piston moves down in one half of crank rotation, the inlet valve opens and fluid enters into the cylinder. In second half crank rotation the piston moves up, the outlet valve opens and the fluid moves out from the outlet. At a time, only one valve is opened and another is closed so there is no fluid leakage. Depending on the area of cylinder the pump delivers constant volume of fluid in each cycle independent to the pressure at the output port.





#### 4. Pump Lift

In general, the pump is placed over the fluid storage tank as shown in figure 5.4.3. The pump creates a negative pressure at the inlet which causes fluid to be pushed up in the inlet pipe by atmospheric pressure. It results in the fluid lift in the pump suction. The maximum pump lift can be determined by atmospheric pressure and is given by pressure head as given below:

$$\text{Pressure Head, } P = \rho gh \quad (5.1.1)$$

Theoretically, a pump lift of 8 m is possible but it is always lesser due to undesirable effects such as cavitation. The cavitation is the formation of vapor cavities in a liquid. The cavities can be small liquid-free zones ("bubbles" or "voids") formed due to partial vaporization of fluid (liquid). These are usually generated when a liquid is subjected to rapid changes of pressure and the pressure is relatively low. At higher pressure, the voids implode and can generate an intense shockwave. Therefore, the cavitation should always be avoided. The cavitation can be reduced by maintaining lower flow velocity at the inlet and therefore the inlet pipes have larger diameter than the outlet pipes in a pump. The pump lift should be as small as possible to decrease the cavitation and to increase the efficiency of the pump.

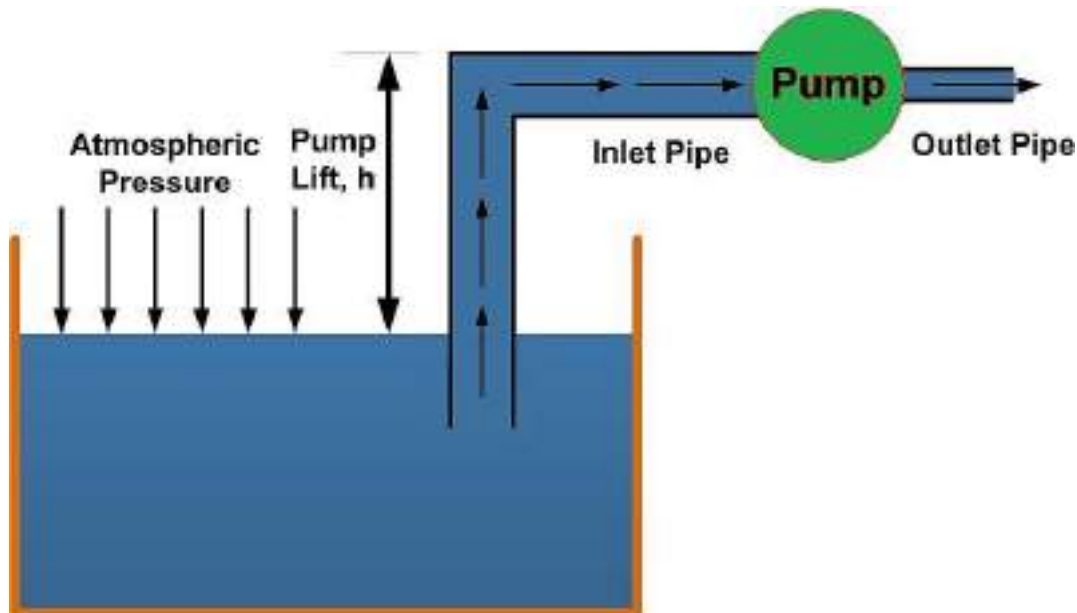


Figure 5.4.4 Pump lift

## 5. Pressure Regulation

The pressure regulation is the process of reduction of high source pressure to a lower working pressure suitable for the application. It is an attempt to maintain the outlet pressure within acceptable limits. The pressure regulation is performed by using pressure regulator. The primary function of a pressure regulator is to match the fluid flow with demand. At the same time, the regulator must maintain the outlet pressure within certain acceptable limits.

The schematic of pressure regulator and various valves placement is shown in figure 5.4.4. When the valve  $V_1$  is closed and  $V_2$  is opened then the load moves down and fluid returns to the tank but the pump is dead ended and it leads to a continuous increase in pressure at pump delivery. Finally, it may lead to permanent failure of the pump. Therefore some method is needed to keep the delivery pressure  $P_1$  within the safe level. It can be achieved by placing pressure regulating valve  $V_3$  as shown in figure 5.4.5. This valve is closed in normal conditions and when the pressure exceeds a certain limit, it opens and fluid from pump outlet returns to the tank via pressure regulating valve  $V_3$ . As the pressure falls in a limiting range, the valve  $V_3$  closes again.

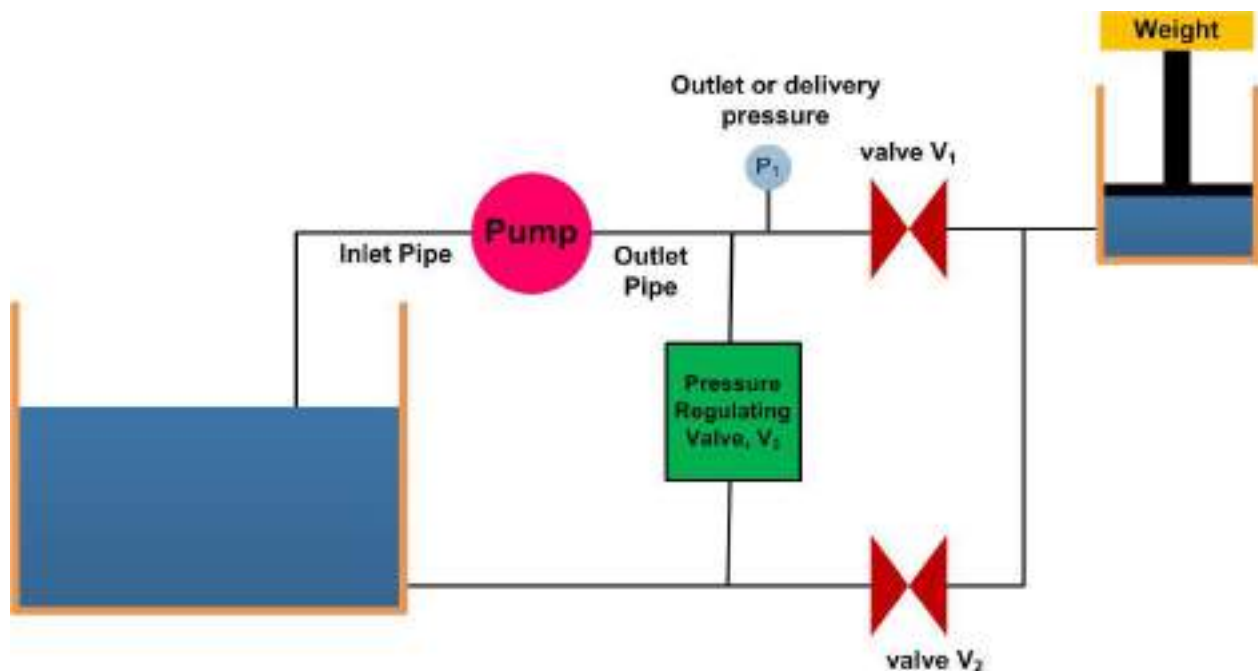


Figure 5.4.5 Schematic of pressure regulation

When valve  $V_1$  is closed, the whole fluid is dumped back to the tank through the pressure regulating valve. This leads to the substantial loss of power because the fluid is circulating from tank to pump and then pump to tank without performing any useful work. This may lead to increase in fluid temperature because the energy input into fluid leads to the increase in fluid temperature. This may need to the installation of heat exchanger in to the storage tank to extract the excess heat. Interestingly, the motor power

consumption is more in such condition because the outlet pressure is higher than the working pressure.

## ***6. Advantages and Disadvantages of Hydraulic***

### ***system***

#### **6.1 Advantages**

- The hydraulic system uses incompressible fluid which results in higher efficiency.
- It delivers consistent power output which is difficult in pneumatic or mechanical drive systems.
- Hydraulic systems employ high density incompressible fluid. Possibility of leakage is less in hydraulic system as compared to that in pneumatic system. The maintenance cost is less.
- These systems perform well in hot environment conditions.

#### **6.2 Disadvantages**

- The material of storage tank, piping, cylinder and piston can be corroded with the hydraulic fluid. Therefore one must be careful while selecting materials and hydraulic fluid.
- The structural weight and size of the system is more which makes it unsuitable for the smaller instruments.
- The small impurities in the hydraulic fluid can permanently damage the complete system, therefore one should be careful and suitable filter must be installed.
- The leakage of hydraulic fluid is also a critical issue and suitable prevention method and seals must be adopted.
- The hydraulic fluids, if not disposed properly, can be harmful to the environment.

## **5.5 Spool Valve Solenoid Operated**

### **Spool valve**

The spool valves derive their name from their appearance. It consists of a shaft sliding in a bore which has large groove around the circumference. This type of construction makes it look like a spool. The spool is sealed along the clearance between moving spool and housing (valve body). The quality of seal or the amount of leakage depends on the amount of clearance, viscosity of fluid and the level of the pressure. The grooves guide the fluid flow by interconnecting or blocking the holes (ports). The spool valves are categorized according to the number of operating positions and the way hydraulic lines interconnections. One of the simplest two way spool valve is shown in Figure 5.5.1. The standard terms are referred as Port 'P' is pressure port, Port 'T' is tank port and Port 'A' and Port 'B' are the actuator (or working) ports. The actuators can move in forward or backward direction depending on the connectivity of the pressure and tank port with the actuators port.

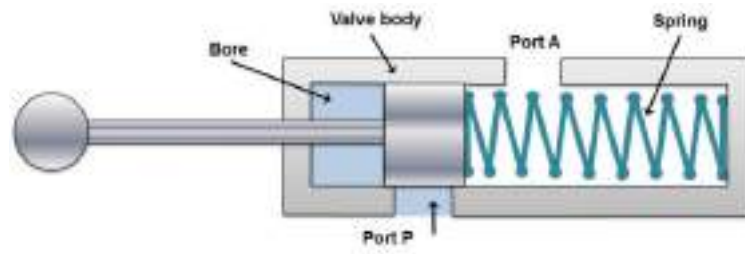


Figure 5.5.1 Valve closed

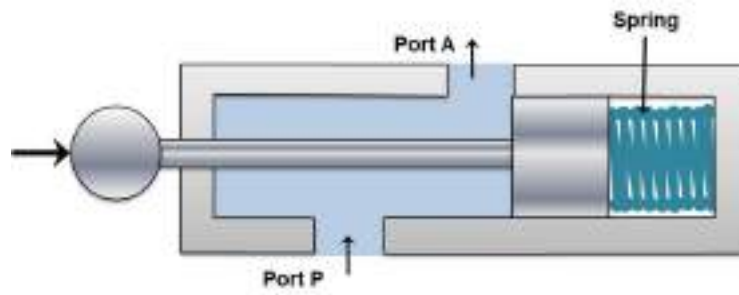


Figure 5.5.2 Valve opened by actuation





## 5.6 Design of simple hydraulic circuits for various applications

The hydraulic and pneumatic elements such as cylinders and valves are connected through pipelines to form a hydraulic or a pneumatic circuit. It is difficult to represent the complex functioning of these elements using sketches. Therefore graphical symbols are used to indicate these elements. The symbols only specify the function of the element without indicating the design of the element. Symbols also indicate the actuation method, direction of flow of air and designation of the ports. Symbols are described in various documents like DIN24300, BS2917, ISO1219 and the new ISO5599, CETOP RP3 and the original American JIC and ANSI symbols.

The symbol used to represent an individual element display the following characteristics:

- Function
- Actuation and return actuation methods
- Number of connections
- Number of switching positions
- General operating principle
- Simplified representation of the flow path

The symbol does not represent the following characteristics:

- Size or dimensions of the component
- Particular manufacturer, methods of construction or costs
- Operation of the ports
- Any physical details of the elements
- Any unions or connections other than junctions

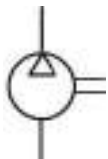

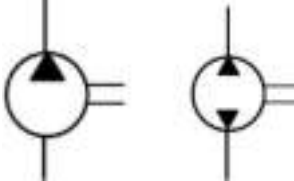
Earlier the ports were designated with letter system. Now as per ISO5599 the ports are designated based on number system. The port designations are shown in table 5.7.1

Table 5.7.1 Symbols for ports

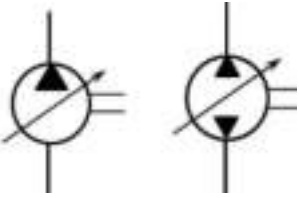
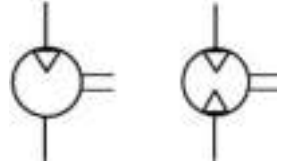
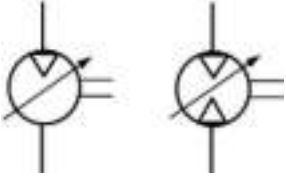
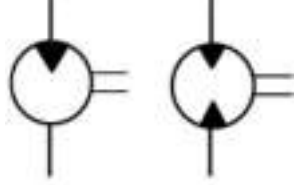
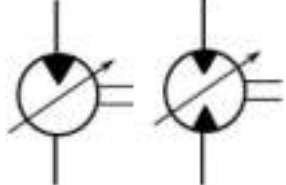
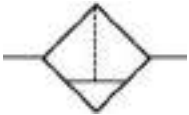
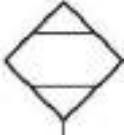
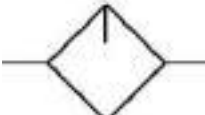
Port	Letter system	Number system
Pressure port	P	1
Working port	A	4
Working port	B	2
Exhaust port	R	5
Exhaust port	S	3
Pilot port	Z	14
Pilot port	Y	12

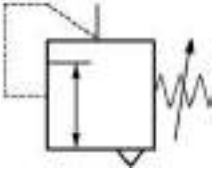
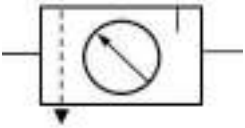
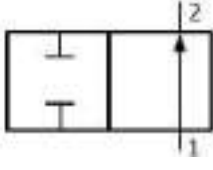
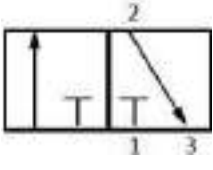
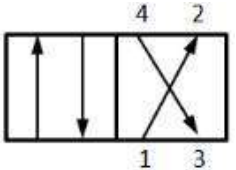
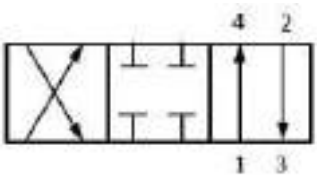
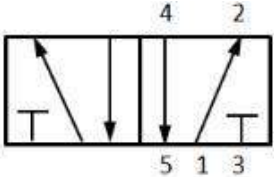
The graphical representation, designation and explanation of various components and equipments used in hydraulic and pneumatic system are given in table 5.7.2. Readers are suggested to study these representations carefully.

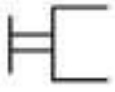
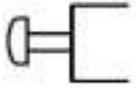
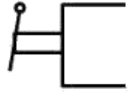

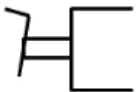
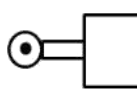
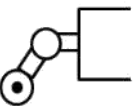

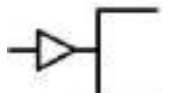


Table 5.7.2 Graphical symbols of hydraulic / pneumatic elements and equipments

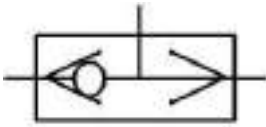
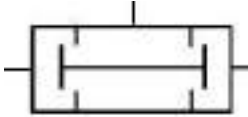
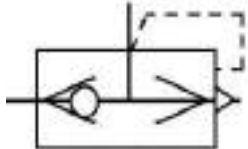
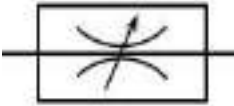
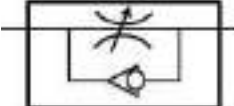
SYMBOL	DESIGNATION	EXPLANATION
<b>Energy supply</b>		
	Air compressor	One direction of rotation only with constant displacement volume
	Air receiver	Compressed air from the compressor is stored and diverted to the system when required
		One direction and two direction of rotation with constant displacement volume

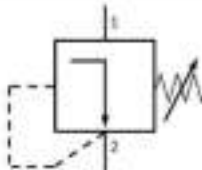
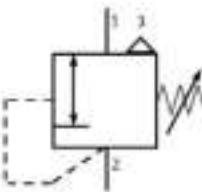


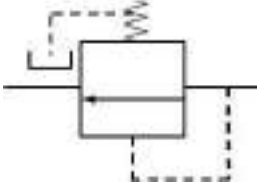
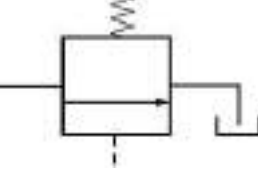
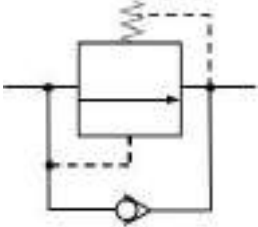
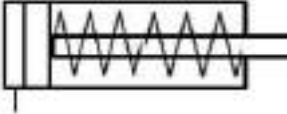
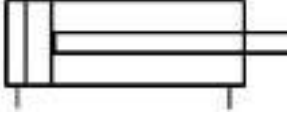
	Hydraulic pump	One direction and two direction of rotation with variable displacement
<b>Rotary actuators</b>		
	Pneumatic motor	One direction and two direction of rotation with constant displacement volume
		One direction and two direction of rotation with variable displacement
	Hydraulic motor	One direction and two direction of rotation with constant displacement volume
		One direction and two direction of rotation with variable displacement
<b>Service units</b>		
	Air filter	This device is a combination of filter and water separator
	Dryer	For drying the air
	Lubricator	For lubrication of connected devices, small amount of oil is added to

		the air flowing through this device
	Regulator	To regulate the air pressure
	FRL unit	Combined filter, regulator and lubricator system
<b>Direction control valves (DCVs)</b>		
	2/2 way valve	Two closed ports in the closed neutral position and flow during actuated position
	3/2 way valve	In the first position flow takes place to the cylinder In the second position flow takes out of the cylinder to the exhaust (Single acting cylinder)
	4/2 way valve	For double acting cylinder all the ports are open
	4/3 way valve	Two open positions and one closed neutral position
	5/2 way valve	Two open positions with two exhaust ports

<b>Direction control valve actuation methods</b>		
	General manual actuation	Manual operation of DCV
	Push button actuation	
	Lever actuation	
	Detent lever actuation	
	Foot pedal actuation	Mechanical actuation of DCV
	Roller lever actuation	
	Idle return roller actuation	
	Spring actuation	
	Direct pneumatic actuation	Pneumatic actuation of DCV
<b>Non return valves</b>		
	Check valve	Allows flow in one direction and blocks flow in other direction
	Spring loaded check valve	

	Shuttle/ OR valve	When any one of the input is given the output is produced
	AND valve	Only when both the inputs are given output is produced
	Quick exhaust valve	For quick exhaust of air to cause rapid extension/retraction of cylinder
<b>Flow control valves</b>		
	Flow control valve	To allow controlled flow
	Flow control valve with one way adjustment	To allow controlled flow in one direction and free flow in other

<b>Pressure control valves</b>		
	Pressure relieving valve	Non relieving type
		Relieving type with overload being vented out

	Pressure reducing valve	Maintains the reduced pressure at specified location in hydraulic system
	Unloading valve	Allows pump to build pressure to an adjustable pressure setting and then allow it to be discharged to tank
	Counter balance valve	Controls the movement of vertical hydraulic cylinder and prevents its descend due to external load weight
<b>Actuators</b>		
	Single acting cylinder	Spring loaded cylinder with retraction taking place by spring force
	Double acting cylinder	Both extension and retraction by pneumatic/hydraulic force

## Pneumatic system

Pneumatic technology deals with the study of behavior and applications of compressed air in our daily life in general and manufacturing automation in particular. Pneumatic systems use air as the medium which is abundantly available and can be exhausted into the atmosphere after completion of the assigned task.

### 1. Basic Components of Pneumatic System:

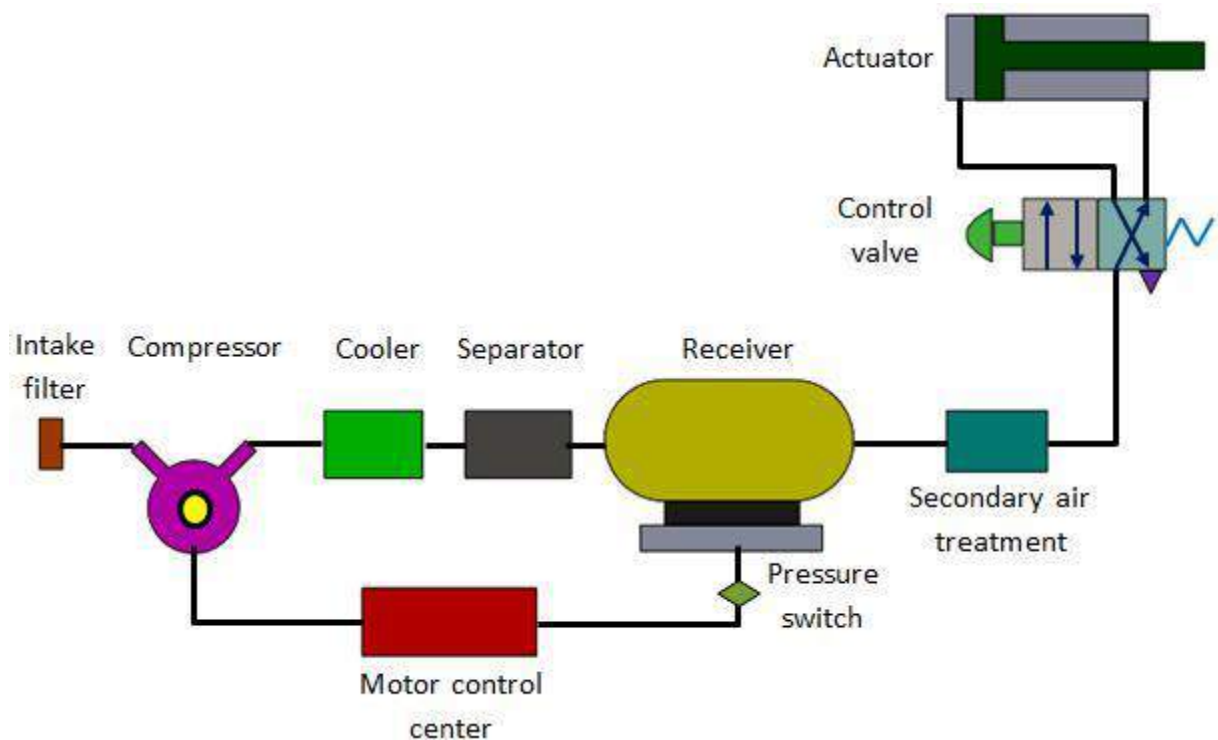


Fig. 6.1.1 Components of a pneumatic system

Important components of a pneumatic system are shown in fig.5.6.1.

- **Air filters:** These are used to filter out the contaminants from the air.
- **Compressor:** Compressed air is generated by using air compressors. Air compressors are either diesel or electrically operated. Based on the requirement of compressed air, suitable capacity compressors may be used.
- **Air cooler:** During compression operation, air temperature increases. Therefore coolers are used to reduce the temperature of the compressed air.
- **Dryer:** The water vapor or moisture in the air is separated from the air by using a dryer.
- **Control Valves:** Control valves are used to regulate, control and monitor for control of direction flow, pressure etc.
- **Air Actuator:** Air cylinders and motors are used to obtain the required movements of mechanical elements of pneumatic system.

- **Electric Motor:** Transforms electrical energy into mechanical energy. It is used to drive the compressor.
- **Receiver tank:** The compressed air coming from the compressor is stored in the air receiver.

These components of the pneumatic system are explained in detail on the next pages.

## 2. Receiver tank

The air is compressed slowly in the compressor. But since the pneumatic system needs continuous supply of air, this compressed air has to be stored. The compressed air is stored in an air receiver as shown in Figure 5.6.2. The air receiver smoothens the pulsating flow from the compressor. It also helps the air to cool and condense the moisture present. The air receiver should be large enough to hold all the air delivered by the compressor. The pressure in the receiver is held higher than the system operating pressure to compensate pressure loss in the pipes. Also the large surface area of the receiver helps in dissipating the heat from the compressed air. Generally the size of receiver depends on,

7. Delivery volume of compressor.
8. Air consumption.
9. Pipeline network
10. Type and nature of on-off regulation
11. Permissible pressure difference in the pipelines

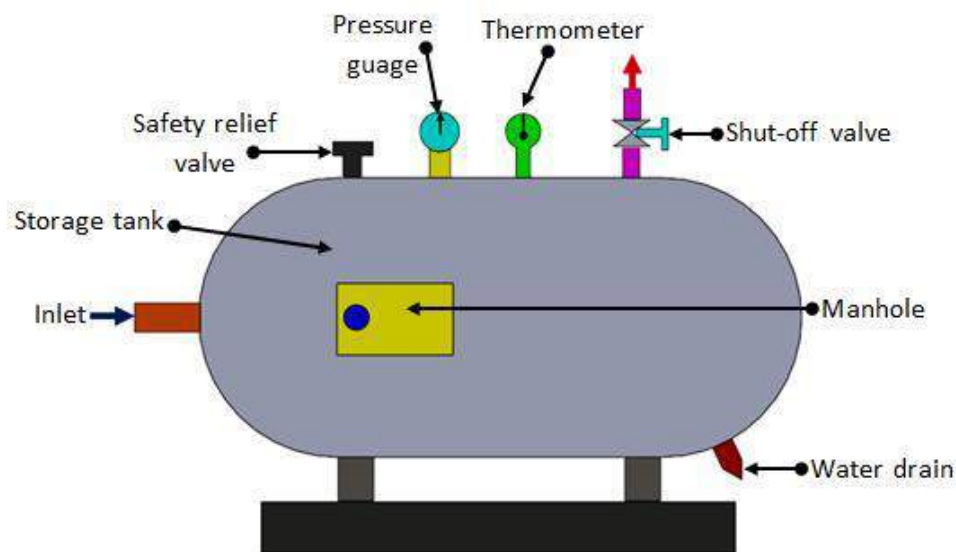


Fig.5.6.2 Air receiver

### 3. Compressor:

It is a mechanical device which converts mechanical energy into fluid energy. The compressor increases the air pressure by reducing its volume which also increases the temperature of the compressed air. The compressor is selected based on the pressure it needs to operate and the delivery volume.

The compressor can be classified into two main types

- Positive displacement compressors and
- Dynamic displacement compressor

Positive displacement compressors include piston type, vane type, diaphragm type and screw type.

#### 3.1 Piston compressors

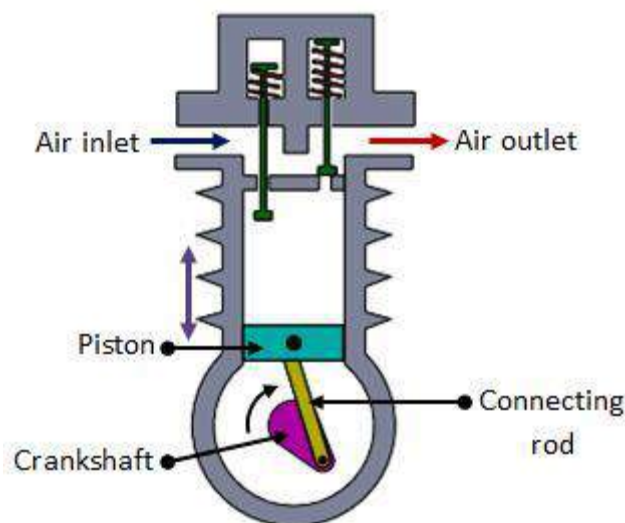


Fig. 5.6.3 Single acting piston compressor

Piston compressors are commonly used in pneumatic systems. The simplest form is single cylinder compressor (Fig. 5.6.3). It produces one pulse of air per piston stroke. As the piston moves down during the inlet stroke the inlet valve opens and air is drawn into the cylinder. As the piston moves up the inlet valve closes and the exhaust valve opens which allows the air to be expelled. The valves are spring loaded. The single cylinder compressor gives significant amount of pressure pulses at the outlet port. The pressure developed is about 3-40 bar.



### 3.2 Double acting compressor

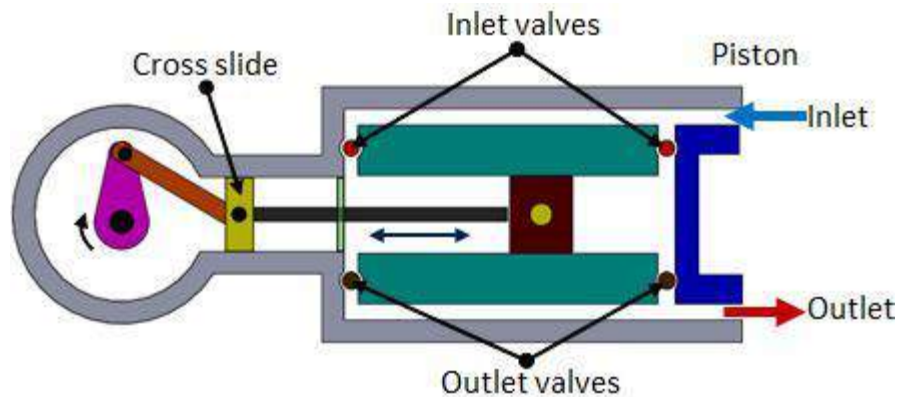


Fig. 5.6.4 Double acting piston compressor

The pulsation of air can be reduced by using double acting compressor as shown in Figure 5.6.4. It has two sets of valves and a crosshead. As the piston moves, the air is compressed on one side whilst on the other side of the piston, the air is sucked in. Due to the reciprocating action of the piston, the air is compressed and delivered twice in one piston stroke. Pressure higher than 30bar can be produced.

### 3.3 Multistage compressor

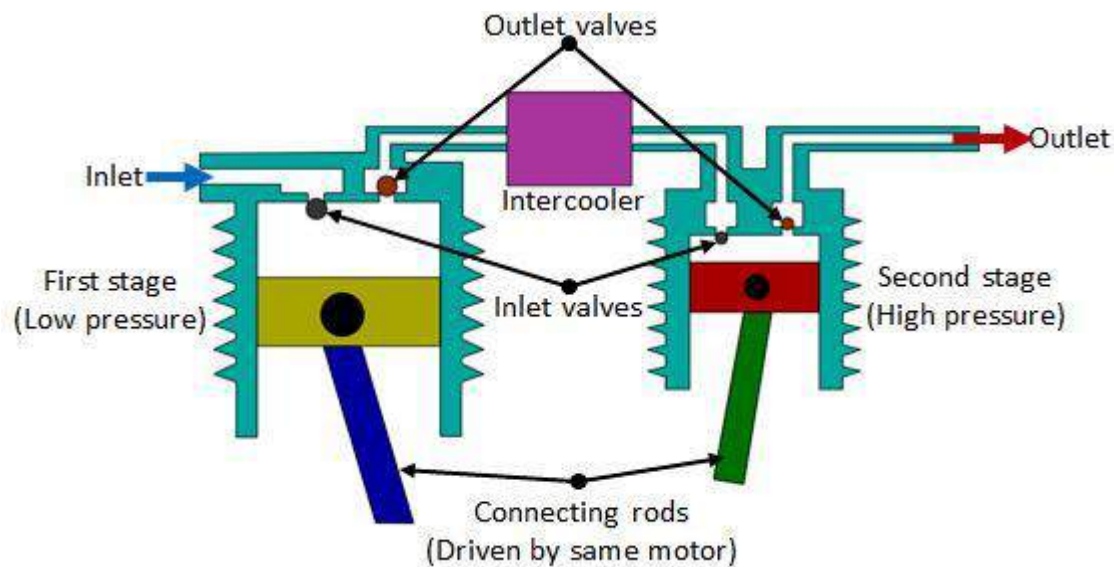


Fig. 6.1.5 Multi-stage compressor

As the pressure of the air increases, its temperature rises. It is essential to reduce the air temperature to avoid damage of compressor and other mechanical elements. The multistage compressor with intercooler in-between is shown in Figure 5.6.5. It is used to reduce the temperature of compressed air during the compression stages. The intercooling reduces the volume of air which used to increase due to heat. The compressed air from the first stage enters the intercooler where it is cooled. This air is given as input to the second stage where it is compressed again. The multistage compressor can develop a pressure of around 50bar.

### 3.4 Combined two stage compressors

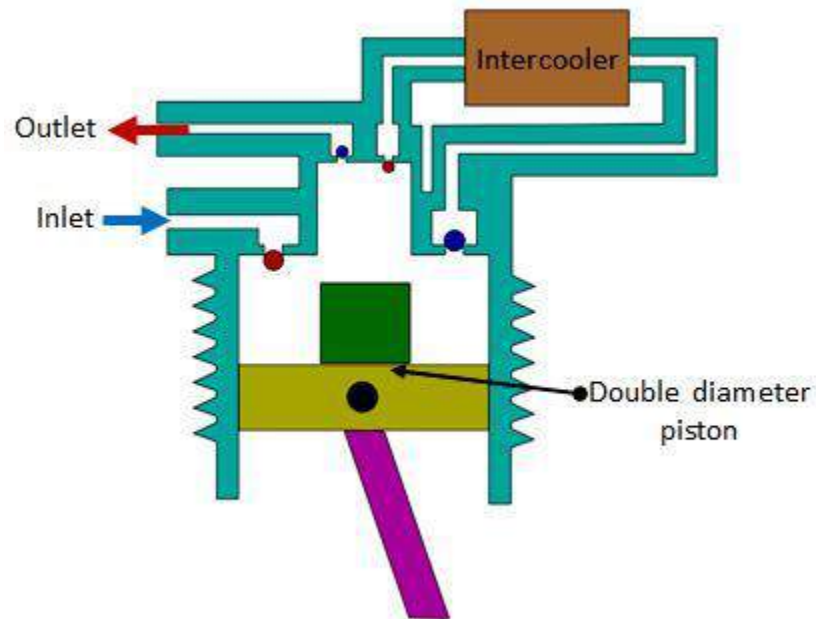


Fig. 5.6.6 Combined two stage compressor

In this type, two-stage compression is carried out by using the same piston (Fig. 5.6.6). Initially when the piston moves down, air is sucked in through the inlet valve. During the compression process, the air moves out of the exhaust valve into the intercooler. As the piston moves further the stepped head provided on the piston moves into the cavity thus causing the compression of air. Then, this is let out by the exhaust port.



**COURSE OUTCOME**

Students will

1. Understand the concept and working of Pneumatic and Hydraulic actuation systems
2. Learn the types and mechanisms of valves
3. Know the concept and depiction of hydraulic systems

**SELF ASSESSMENT QUESTIONS**

1. With a neat block diagram explain Hydraulic actuation systems
2. Describe the working of spool valves
3. Draw vane pumps.
4. Explain the various units of hydraulic system
5. Explain the main features and functions of rotary actuators.

**FURTHER READING**

1. Mechatronics and microprocessor, Dr H.D.Ramachandra, Sudha Publications, Bangalore, 2018